



700 C SERIES



KIP 700 C Series **User Manual**

For SN 152xxxxx

Thank you for purchasing the KIP 700 Series.

This Hardware Operation Guide contains functional and operational explanations for the KIP 700 Series.

Please read this Hardware Operation Guide carefully before using the Printer.

Please keep this Hardware Operation Guide for future reference.

1. When this product is installed in North America.

This product complies with part 15 of the FCC Rules. Operation is subject to the following two conditions: (1) This product may not cause harmful interference, and (2) this device must accept any interference received, including interference that may cause undesired operation.

FCC CAUTION

Changes or modifications not expressly approved by the party responsible for compliance could void the user's authority to operate the product.

Note: This product has been tested and found to comply with the limits for a Class A digital equipment, pursuant to part 15 of the FCC Rules. These limits are designed to provide reasonable protection against harmful interference when the product is operated in a commercial environment. This product generates, uses, and can radiate radio frequency energy and, if not installed and used in accordance with the instruction manual, may cause harmful interference to radio communications. Operation of this product in a residential area is likely to cause harmful interference in which case the user will be required to correct the interference at his own expense.

This product complies with Part 15 of FCC Rules and Industry Canada licence-exempt RSS standard(s). Operation is subject to the following two conditions: (1) this product may not cause interference, and (2) this product must accept any interference, including interference that may cause undesired operation of this product.

Le présent appareil est conforme aux la partie 15 des règles de la FCC et CNR d'Industrie Canada applicables aux appareils radio exempts de licence. L'exploitation est autorisée aux deux conditions suivantes : (1) l'appareil ne doit pas produire de brouillage, et (2) l'utilisateur de l'appareil doit accepter tout brouillage radioélectrique subi, même si le brouillage est susceptible d'en compromettre le fonctionnement.

2. When this product is installed in Europe

This product complies with the requirements in CISPR 32 for a Class A computing equipment. Operation of this product in a residential area may cause unacceptable interference to radio and TV reception requiring the operator to take whatever steps are necessary to correct the interference.

Do not install product around other electronic equipment or other precision instruments. Other equipment may be effected by electrical noise during operation.

If the product is installed near other electronic equipment, such as a TV or a radio, interference to said equipment, such as noise or flickering, may occur. Use a separate power line and install the PRINTER as far as possible from said equipment.

KIP 700 Series is an ENERGY STAR qualified multifunction device.



The International ENERGY STAR® Office Equipment Program is an international program that promotes energy saving through the penetration of energy efficient computers and other office equipment. The program backs the development and dissemination of products with functions that effectively reduce energy consumption. It is an open system in which business proprietors can participate voluntarily. The targeted products are office equipment such as computers, monitors, printers, facsimiles, copiers, scanners, and multifunction devices. Their standards and logos are uniform among participating nations.

The symbol shown indicates that this product conforms to Directive 2012/19/EC of the European Parliament and the council of 4 July 2012 on waste electrical and electronic equipment (WEEE) and does not apply to countries outside of EU.



Only For EU Member States

Das Gerät ist nicht für die Benutzung am Bildschirmarbeitsplatz gemäß BildscharbV vorgesehen.

The symbol shown indicates that this product conforms to SJ/T11364-2006 of People's Republic of China Electronic Industry Standard and does not apply to countries outside of People's Republic of China.



The symbol shown indicates that this product conforms to GB 18455-2001, SJ/T 11364-2006 of National Standard of the People's Republic of China and does not apply to countries outside of People's Republic of China.

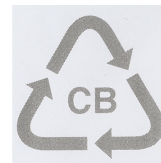

Safety Warning

The following warnings are very important in order to safely use this product.
These notes are important in preventing danger to the operator or operation of the printer.

The following symbols are found throughout the USER'S Manual and have the following meaning:



WARNING

This WARNING mark means that there is a possibility of death or serious injury if you ignore or do not follow the said instruction.



CAUTION

This CAUTION mark means that there is a possibility of injury or physical damage if you ignore or do not follow the said instruction.

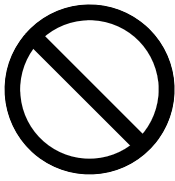

When marked with this symbol, "DO NOT ATTEMPT".



When marked with this symbol, "pay close attention to".



There are extremely hot parts inside.
Do not touch any parts, or you will be burnt.



WARNING

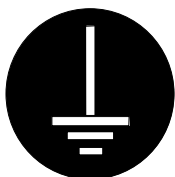

Ground the product with a correct ground source or you may be electrically shocked.



1. The Power source should be as follows:
Europe; 220V to 240V plus 10% or minus 10%, 50/60Hz, 16A or higher
North America; 208V plus 10% or minus 10%, 50/60Hz, 16A or higher
2. Use a circuit with a dedicated breaker.
3. Install the product as close to the wall outlet as possible.
4. If you wish to move the printer, please contact your service personnel.



1. Do not remove the screw and do not open the cover if not instructed to do so in this User's Manual. If you ignore this warning, you may be burnt or receive an electric shock due to a hot item or electrically charged part inside of the printer.
2. Do not disassemble or tamper with the printer. It may result in a fire or an electrical shock.

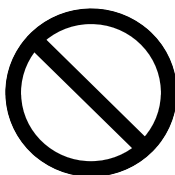

1. Do not plug in the printer into a multi-wire connector in which some other equipment is plugged into. It may cause a fire due to outlet overheating.
2. Do not damage the Power Cord by stepping on or placing heavy items on it. If the Power Cord is damaged, it may cause a fire or you may receive an electric shock. **REPLACE THE CORD IF DAMAGED!**

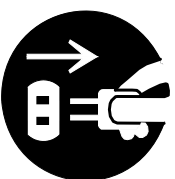

1. Do not put a flower vase, a flowerpot or any water-filled item on the product. Spilt water could cause a fire or an electric shock.
2. If the product generates an abnormal smell or noise, turn it off and unplug it from the wall electrical outlet immediately.



Do not throw the toner into a fire or other sources of heat, as it can explode.



CAUTION

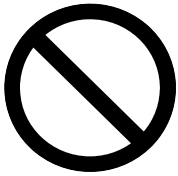

1. Do not install the printer in a humidified room or a dusty room. Also do not install the printer on an unstable floor as injuries may occur.
2. This equipment is not suitable for use in locations where children are likely to be present.

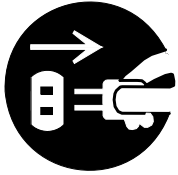

1. Unplug the printer before you move it. The power cord may be damaged and it may result in a fire or electric shock.
2. If you do not use the printer for a long duration (holidays, company shutdown) turn off and unplug the printer from the outlet for safety.

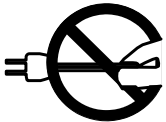

Do not pull the cord when you unplug the printer as you may damage the Power Cord.



There are hot items inside of the printer. Take great care not to touch these items when you remove mis-fed media.



Ventilate the room well if you print in a small area.

POWER CORD INSTRUCTION

The installation of (or exchange to) a power plug which fits in the wall outlet of the installation location shall be conducted in accordance with the following:



WARNING

Select a power plug which meets the following criteria;

- The plug has a voltage and current rating appropriate for the product's rating marked on its name plate.
- The plug meets regulatory requirements for the area.
- The plug is provided with a grounding pin or terminal.

If the appropriate plug does not fit the wall outlet in the installation, the customer shall install an appropriate outlet.

Connector Type:

Configuration	Standard	Rating	Usually found in
	IEC60320:C19	20A 250V (UL) 16A 250V (IEC)	

Plug Type: Model Rating 208V-240V

Configuration	Standard	Rating	Usually found in
	NEMA6-20	20A 250V	North America (UL Listed)
	CEE7/7	16A 250V	European countries
	KS C 8305	16A 250V	Korea
	AS/NZS 3112	16A 250V	Australia New Zealand
	GB1002 GB2099.1	16A 250V	China
	IRAM 2073	16A 250V	Argentina

Cord Type

Standard	Rating	Usually found in
SJT 3X12AWG Long <4.5m	20A 250V	North America (UL Listed)
HO5VV-F 3X1.5mm ²	16A 250V	European countries Argentina
RVV 3X1.5mm ²	16A 250V	China

Chapter 1

Introduction

	Page
1.1 Installation Requirements	1- 2
1.2 Originals Prohibited from Duplication	1- 3
1.3 Features	1- 4
1.4 Specifications	1- 5
1.4.1 Printer	1- 5
1.4.2 Scanner (MFP Model)	1- 7
1.5 Appearance	1- 8
1.5.1 Front view	1- 8
1.5.2 Left side view	1- 9
1.5.3 Right side view	1- 10
1.5.4 Rear view	1- 11
1.6 Specifications for Print Media	1- 12
1.6.1 Papers not to be used	1- 12
1.6.2 Paper Storage	1- 13
1.6.3 Environmental Considerations	1- 14
1.7 Specifications for Originals	1- 15
1.7.1 Original Standards	1- 15
1.7.2 Special Documents	1- 15
1.7.3 “Do Not Scan” Originals	1- 16

1.1 Installation Requirements

The following conditions are required for installation of the equipment.



1. Power source should be rated as:
Europe: 220V - 240V +/-10%, 50/60Hz, 16A or higher
North America: 208V +/-10%, 50/60Hz, 16A or higher
2. The equipment must be on an exclusive circuit.
3. The outlet must be near the equipment and easily accessible.



1. Make sure to connect this equipment to a grounded outlet.
2. For PLUGGABLE EQUIPMENT, the socket-outlet shall be installed near the equipment and shall be easily accessible.



1. The installation site must not have open flames, dust or ammonia gases.
2. Not to be installed near solvent based printers, corrosive gases or devices that emit them.
3. The equipment must not be exposed to the air vents from air conditioners. It may affect the image quality.
4. The equipment should not be exposed to the direct sunlight. Please draw curtains to block any sunlight. When you open the Upper Unit to remove a mis-feed, do not expose the Photoconductive Drum to strong (intense) light as this will damage the Drum.



Ventilate the room, if required.

The site temperature range = 10 to 30 degrees Centigrade, with the humidity between 15% to 80% RH. (NON-CONDENSING)

Keep the printer away from water sources, boilers, humidifiers, refrigerators, kerosene (oil) stoves or other printers which emit gases.

Keep ample room around the equipment to ensure comfortable operation.

(Refer to the following figure.)

The equipment must be leveled and the floor strength must be ample to sustain the weight of the equipment.

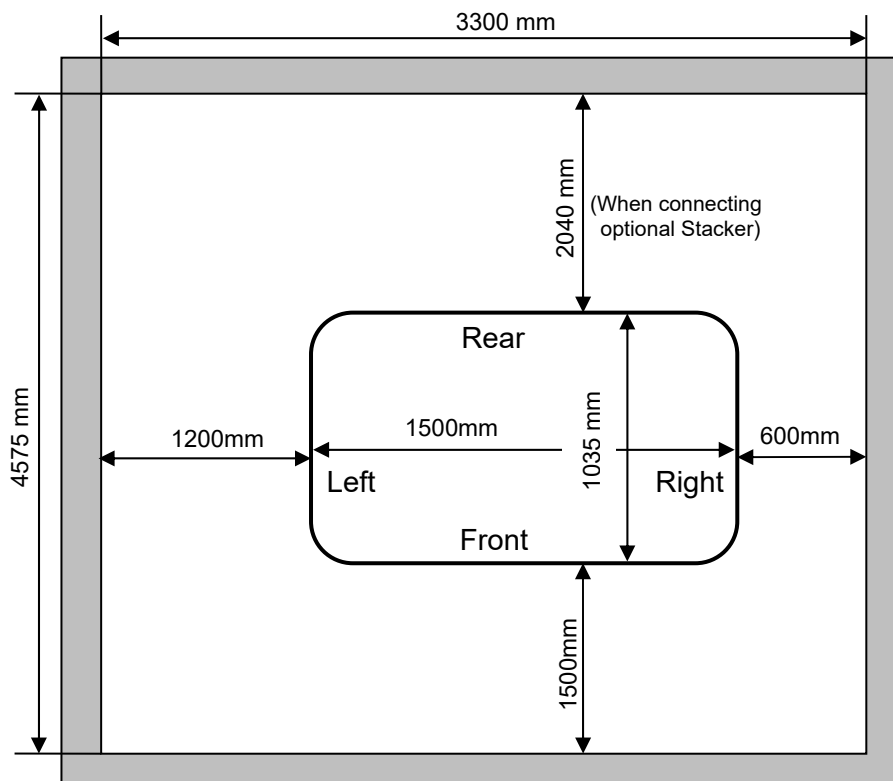

1.2 Originals Prohibited from Duplication

It may be illegal to duplicate or copy certain types of originals and you may be punished by local or regional laws, if copies are made of these types of documents.

Please be aware of your local or regional laws and which originals they forbid you to duplicate.

Some Examples:

[Originals prohibited from copying by law(s)]

1. Do not copy Currency (Bill, Money, Bank Note, etc.), Government issued Negotiable Instruments (National Bonds, Security, Local Debt Bonds, etc.).
2. Do not copy Foreign Currency or Foreign Negotiable Instruments.
3. Do not copy unused postal stamps or government postcards without permission to make replica from said Governments.
4. Do not copy Government issued revenue stamps, certificate stamps that are prescribed by Liquor Tax Act or the Commodity Tax Act.

[Special items which require your attention]

1. The government issues warnings if you are to copy private issued securities (stock certificate, draft, check, goods ticket, etc.), commutation ticket or book of tickets, excluding that some specific company copies such originals as many as it requires for its own business.
2. We recommend you not copy originals as government issued passports, public or private issued licenses, automobile inspection certification, ID and tickets passes or meals.

[Originals protected by the copyright]

It is prohibited to copy originals such as books, music, paintings, printed copies, maps, drawings, movie posters and pictures which are protected by the copyright laws. Please refer to your local or regional laws.

1.3 Features

- (1) Electro Photographic, full color LED printer/MFP using KIP Contact Control Technology with KIP Contact Array Charging and KIP Image Smoothing Technologies.
- (2) The **KIP 700 Series** have a wide product range to meet various customers' requirements.
 - MFP model / Printer model
 - 4 Roll model / 2 Roll model
 - High Speed model / Standard Speed model
- (3) Supported widths and lengths for Roll Media:
 - Maximum width : 914mm (36")
 - Minimum width : 279.4mm (11")
 - Maximum length : 6,000mm (for A0/36")
 - Minimum length : 210mm (8.5")
- (4) Optional Cut Sheet Feeder: single sheet - manual feed (factory option)
- (5) Transfer Belt Technology permits accurate color registration.
- (6) Prints are ready for immediate use with high durability to include UV and water resistant.
- (7) 15.6 inch multi-touch panel allows for tablet-like operation and image viewing.
- (8) Easy access to the USB port permits quick prints using easy touch panel functions.
- (9) Use of optional hardware finisher devices helps handling of the finished prints. Available optional finisher are;
 - Online Auto Stacker (Print Capacity: 700 D size sheets of 20lb Bond)
 - Online Folder
- (10) Feature rich, KIP System K Software applications and drivers.

1.4 Specifications

1.4.1 Printer

Subject	Specification												
Model	KIP 700 Series 2 or 4 roll wide format color & monochrome printer or MFP												
Type	Console, full color and monochrome print/scan												
Printing method	LED Array Electro Photography, Dry Toner												
Color	CMYK												
Photoconductor	Organic Photoconductive Drum												
Print Productivity	High Speed model: <ul style="list-style-type: none"> • Color Print = 10 D size (Eng) per minute (100mm/s process speed) • B/W Print = 12 D size per minute (120mm/s) • Heavy Media = 6 D size per minute (60mm/s) Standard Speed model: <ul style="list-style-type: none"> • Color Print = 6 D size (Eng) per minute (60mm/s process speed) • B/W Print = 8 D size per minute (80mm/s) • Heavy Media = 6 D size per minute (60mm/s) 												
Exposure method	Multi-Level (9 levels) LED Print Head												
Resolution	600dpi x 2400dpi												
Print width	Maximum : 914.4mm (36 inches) Minimum : 279.4mm (11 inches) (Roll Deck) : 420mm (16.6 inches) (anual, standard size only)												
Print length	Maximum : <table border="1" data-bbox="507 1025 1401 1144"> <tbody> <tr> <td>Plain Paper / Bond</td> <td>5x standard portrait</td> <td>6000mm in case of A0/36"</td> </tr> <tr> <td>Tracing Paper / Vellum</td> <td>1x standard portrait</td> <td></td> </tr> <tr> <td>Film</td> <td>1x standard portrait</td> <td></td> </tr> <tr> <td>Glossy Paper</td> <td>1x standard portrait</td> <td></td> </tr> </tbody> </table> Minimum : 210mm (8.5 inches) (Roll Deck) : 420mm (16.6 inches) (Bypass Feeder, standard size only) NOTE : If the print is longer than the above, KIP does not guarantee image quality or the reliability of the media feeding system.	Plain Paper / Bond	5x standard portrait	6000mm in case of A0/36"	Tracing Paper / Vellum	1x standard portrait		Film	1x standard portrait		Glossy Paper	1x standard portrait	
Plain Paper / Bond	5x standard portrait	6000mm in case of A0/36"											
Tracing Paper / Vellum	1x standard portrait												
Film	1x standard portrait												
Glossy Paper	1x standard portrait												
Paper Exit	Top Front Stacking: standard size inch - A (landscape) / B / C / D / E (portrait) metric - A0 (portrait) / A1 / A2 / A3 / A4 (landscape) Rear Exit: use with Special Media, Auto Stacker, Folder												
Warm up time	Less than 5 minutes (At 23 degrees centigrade, 60% RH and 208V)												
Fusing method	Heat roller fusing												
Development	Contact, mono component non-magnetic development system												
Drum charging	Charging Roller (KIP CAC Technology)												
Transfer	Transfer roller												
Separation	Electrostatic separation (AC)												
Media feeding method	Automatic (4 or 2 rolls) and manual												
Rating power	US: 208V (+/-10%), 16A, 50/60Hz EUR: 220 to 240V (+/- 10%), 14A, 50/60Hz												
Interface	Ethernet 10BASE-T, 100 BASE –TX, 1000 BASE-T USB 2.0/3.0 (5VDC max)												
Power consumption	Ready : 560W Color Printing (10 D) : 2100W Mono Printing (12 D) : 2200W Maximum : 3400W Cold Sleep : 3.4W												

Subject	Specification
Acoustic noise	Less than 65dB (Printing) NOTE : Impact noise such as cutting sound is excluded. Less than 60dB (Ready) The highest sound pressure according to EN ISO 7779 is 70dB (A) or less.
Dimensions	2 Roll Printer : 1500mm (W) x 1035mm (D) x 888mm (H) 2 Roll MFP : 1500mm (W) x 1035mm (D) x 1038mm (H) 4 Roll Printer : 1500mm (W) x 1035mm (D) x 1138mm (H) 4 Roll MFP : 1500mm (W) x 1035mm (D) x 1288mm (H) NOTE: Touch panel and upper trays are not included.
Weight	2 Roll Printer : about 389kg 2 Roll MFP : about 413kg 4 Roll Printer : about 450kg 4 Roll MFP : about 474kg
Media (Recommended)	Bond / Plain Paper - 67g/m ² to 120g/m ² Gloss - 120g/m ² NOTE: Refer to your regional media guide.
Environmental condition	Standard Environment : 23°C and 60% Temperature 10 to 30 degrees centigrade Humidity 15 to 80% RH
Storage of consumables	Print media Wrap the media to prevent access of moisture Toner Keep the bottles away from direct sunlight, and store between 0 - 35 °C and 10 - 85% RH.

 NOTE

Specifications are subject to change without notice.

1. 4. 2 Scanner (MFP model)

Subject	Specification
Scanning method	Contact Image Sensor (CIS) (5 pieces of A4 sized CIS)
Light source	LED (R/G/B)
Scanning speed (600 dpi, normal quality) (max)	Monochrome : 65mm/s Grayscale : 65mm/s Color : 22mm/s NOTE: Actual speed may vary by the scan software.
Setting of original	Face up
Starting point of scan	Center
Scan width	Max : 914.4mm / 36" Min : 210mm
Scan length	Max : 6,000mm / 19.7ft (Including the margin area) Min : 210mm / 8.5" (Including the margin area) NOTE : If the original is longer than 6,000mm, image quality or the feeding reliability is not guaranteed.
Optical resolution	600dpi
Digital resolution	200 / 300 / 400 / 600 dpi
Original transportation	Sheet through type
Transportable original thickness	Max : 1.60mm Min : 0.05mm NOTE : Suggest to change "It does not guarantee both scan/copy image quality and original feeding reliability in case the original is non-standard size one of which thickness is 0.25mm or thicker.

NOTE

Specifications are subject to change without notice.

1.5 Appearance

1.5.1 Front view



	Name of part	Function																								
1	Print Tray	These trays catch ejected prints.																								
2	Scanner Unit (MFP model)	Read the original with this unit when you make scan or copy.																								
3	Scan Abort Button (MFP model)	While scanning: emergency stop At Standby position: eject																								
4	Start Button (MFP model)	Starts scanning if the controlling software requires user intervention.																								
5	User Interface	This is a Touch Screen, and many kinds of user operation are available. PLEASE DO NOT push the LCD area too strong.																								
6	Roll Deck	Roll media can be loaded here. (4 or 2 Rolls)																								
7	Manual Feeder (option)	Feed a cut sheet paper from the Manual Feeder. Open (pull) the Manual Feeder to remove mis-feed sheet inside the printer.																								
8	Status Indicator	LED indicator indicates the following printer status. <table border="1" style="width: 100%; border-collapse: collapse;"> <thead> <tr> <th>Color</th> <th>Condition</th> <th>Status</th> </tr> </thead> <tbody> <tr> <td>Green</td> <td>Light</td> <td>Ready, Printing</td> </tr> <tr> <td>Green</td> <td>Blink</td> <td>Warming up.</td> </tr> <tr> <td>Orange</td> <td>Light</td> <td>Operator Call Error</td> </tr> <tr> <td>Red</td> <td>Light</td> <td>Service Call Error</td> </tr> <tr> <td>Blue</td> <td>Light</td> <td>Warm sleep</td> </tr> <tr> <td>Blue</td> <td>Light</td> <td>Cold sleep</td> </tr> <tr> <td>light purple</td> <td>Light</td> <td>When printer is power-off and print controller is still power on.</td> </tr> </tbody> </table>	Color	Condition	Status	Green	Light	Ready, Printing	Green	Blink	Warming up.	Orange	Light	Operator Call Error	Red	Light	Service Call Error	Blue	Light	Warm sleep	Blue	Light	Cold sleep	light purple	Light	When printer is power-off and print controller is still power on.
Color	Condition	Status																								
Green	Light	Ready, Printing																								
Green	Blink	Warming up.																								
Orange	Light	Operator Call Error																								
Red	Light	Service Call Error																								
Blue	Light	Warm sleep																								
Blue	Light	Cold sleep																								
light purple	Light	When printer is power-off and print controller is still power on.																								

1. 5. 2 Left side view

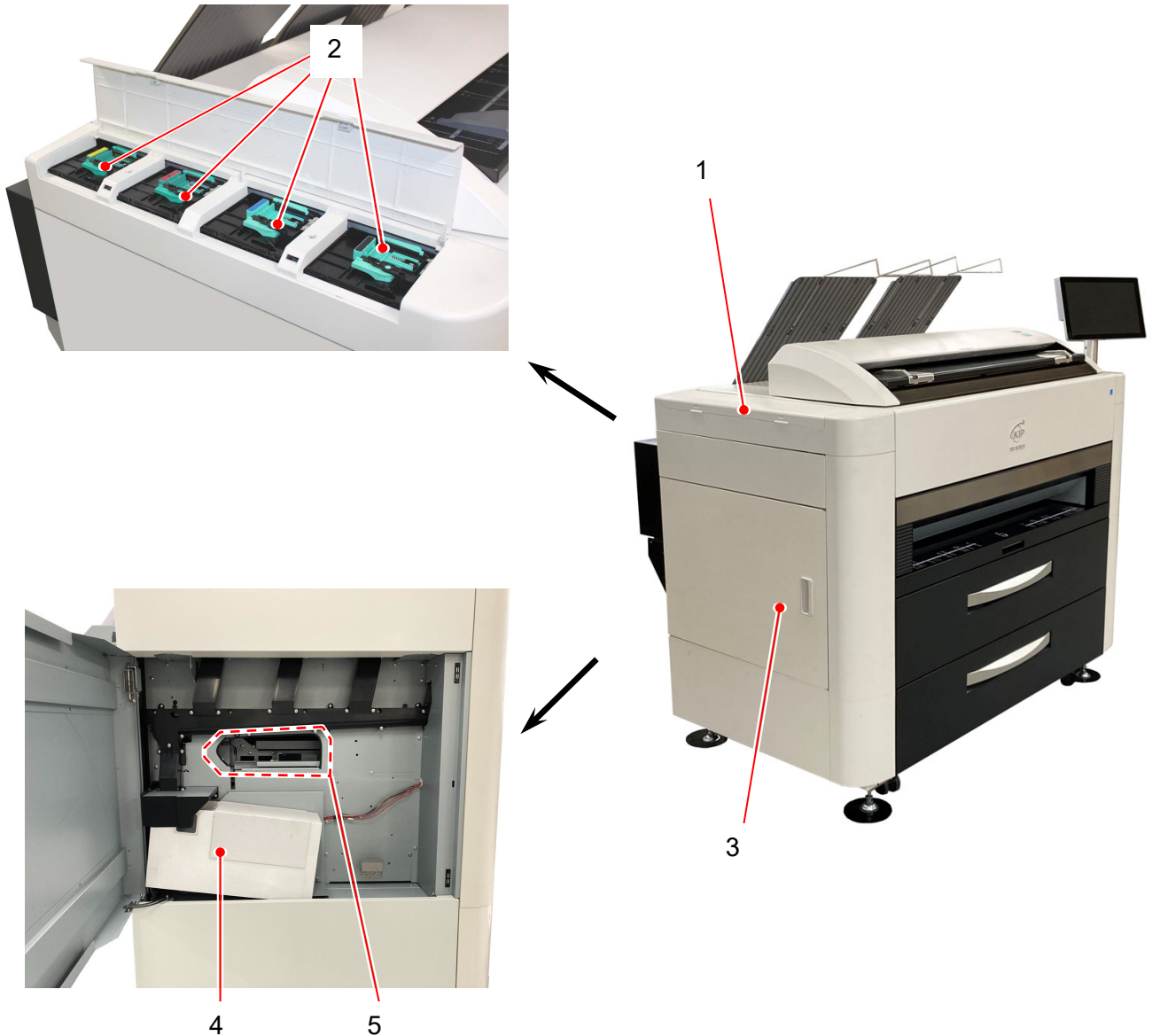

	Name of part	Function
1	Toner Cover	Open here to access the Toner Supply Port.
2	Toner Supply Port	Toner Cartridge (C, M, Y, K) to be set here to add toner to the system.
3	Left Door	Open here to access Toner Receptacle and jammed sheet inside the printer.
4	Toner Receptacle	Collects the waste toner.
5	Opening	A jammed sheet in the Feeder Unit can be removed from here.

1. 5. 3 Right side view



	Name of part	Function
1	USB Port	Your USB flash memory can be used here. (5VDC max.)
2	Power Switch	Turn on/off the Printer.

1.5.4 Rear view

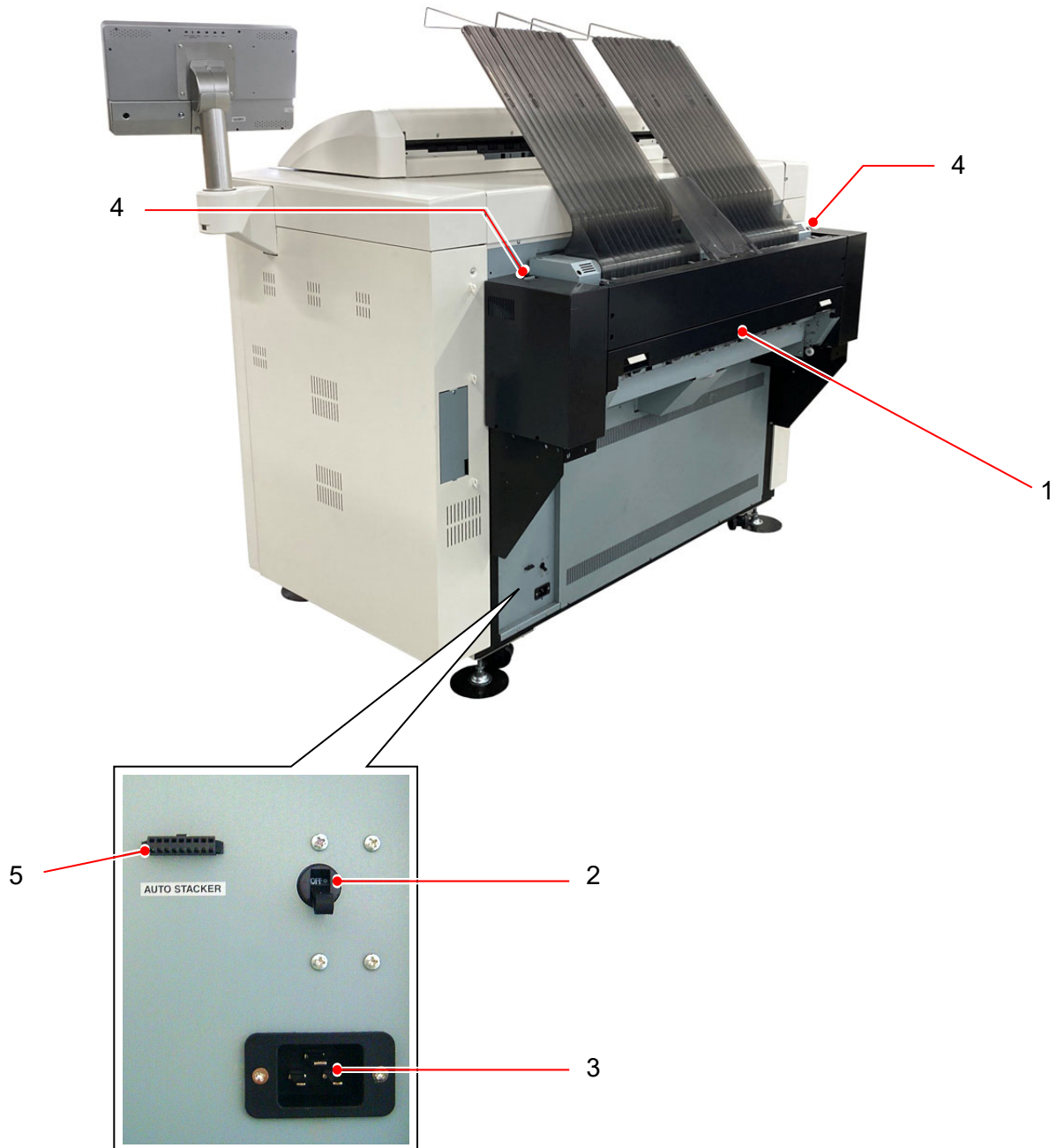

	Name of part	Function
1	Fuser Cover	Prints come from the opening on this. Open the Fuser Cover when you remove the misfeeds inside the Fuser Unit.
2	Breaker	It is possible to shut off supplying the AC power.
3	Inlet Socket	Connect the Power Cord here.
4	Fuser Release Lever	Pull the Fuser Release Lever and slide the Fuser Unit rearward to remove misfeeds inside the Fuser Unit.
5	Stacker Port	For a dedicated Auto Stacker for the Printer

1. 6 Specifications for Print Media

1. 6. 1 Papers not to be used

Do not use the following kinds of printing paper. Doing so may damage the print engine.

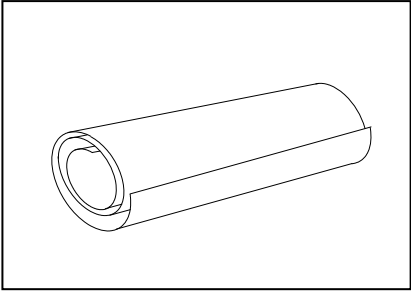
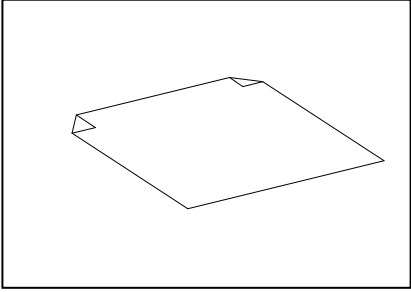
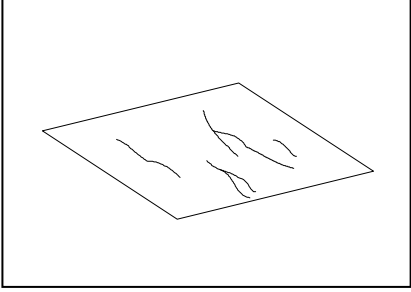
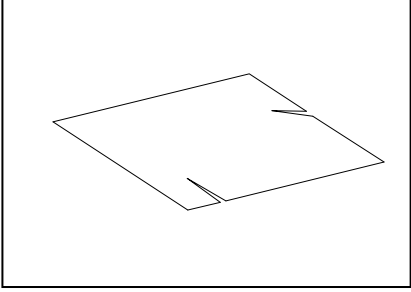
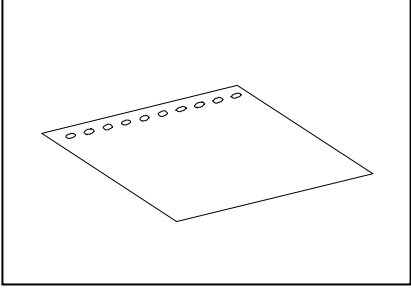
Excessively curled (a diameter of 50 mm or less)	
Folded	
Creased	
Torn	
Punched	

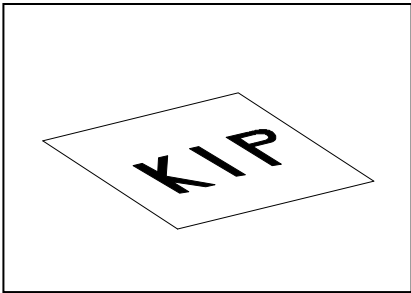
Pre-printed	
Extremely slippery	
Extremely sticky	
Extremely thin and soft	
OHP Film	

CAUTION

Do not use the paper with staple, or do not use such conductive paper as aluminium foil and carbon paper.

The above may result in a danger of fire

NOTE

- (1) Print image may become light if printed on a rough surface of the paper.
- (2) Print image may become defective if the print paper has an excess curl.
- (3) It will become a cause for paper mis-feed, defective print image or paper creasing if you use a paper that does not satisfy the specification.
- (4) Do not use a paper of which surface is very special, such as thermal paper, art paper, aluminium foil, carbon paper and conductive paper.
- (5) Do not use papers with unpacked (exposed in high / low temperature & humidity) in a long period. Such papers may result in mis-feed, defective image or paper creasing.
- (6) Tracing paper exposed to air over a long period tends to cause a defective printing. Removing one round on the surface of the tracing roll paper from the beginning is recommended.
Refer to [2.3 Replacing Roll Media].

1. 6. 2 Paper Storage

Keep the paper in the custody taking care of the following matters.

1. Do not expose the paper to the direct sunlight.
2. Keep the paper away from high humidity. (It must be less than 70%)
3. Put the paper on a flat place
4. If you will keep the paper in the custody, which you have already unpacked, put it into the polyethylene bag to avoid the humidity.

1. 6. 3 Environmental considerations

Take the necessary actions for environmental conditions as shown below.

Humidity(%)	Possible problem	Necessary treatment
Low ↑	“Void of image”, “crease of paper” and other problems occurs when you print with plain paper and tracing paper.	1. Install the humidifier in the room, and humidify the room air. 2. Remove the paper from the machine right after the completion of print, and keep it in a polyethylene bag.
40%	“Void of image” occurs when you print with tracing paper.	If you will not make print soon, remove the tracing paper from the machine and keep it in a polyethylene bag.
70%		Remove the paper from the machine after everyday use, and keep it in a polyethylene bag.
↓ High	“Void of image”, “crease of paper” and other problems occurs when you print with plain paper and tracing paper.	Remove the paper from the machine right after the completion of print, and keep it in a polyethylene bag.

! NOTE

“Void of image” and “crease of paper” will occur in case of extremely high or low humidity.

Normal Print

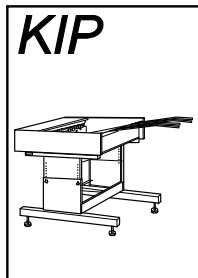

If the media is humidified;

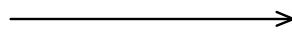

Crease of paper

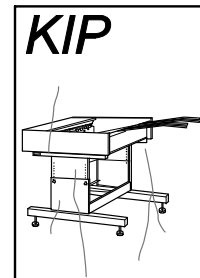

Normal Print



If the media is humidified;

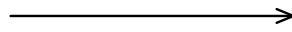

Loss of image



1.7 Specifications for Originals

A scan original must satisfy the following specifications.

Thickness	0.05mm to 1.60mm
Width	210mm to 914.4mm
Length	210mm to 6,000mm

NOTE :

1. Image quality for an original with 0.25mm or thicker is guaranteed only in a standard size even the scanner physically accepts it.
2. Image quality for an original over 6,000mm in length is not guaranteed.

1.7.1 Original Standards

- (1) The width of original must range from 8.5" to 36" (210mm to 914.4mm).
- (2) The length of original must range 8.5" (210mm) to 6,000mm
- (3) The thickness of original must range from 0.05mm to 0.25mm.
- (4) The shape of original must be square, and it must be standard sized.
- (5) The type of original must belong to any of the followings.
 - Plain paper
 - Coated paper (High or middle class plain paper is coated with the paint.)
 - Tracing paper
 - Pansy Trace Paper (Both sides of the film is sandwiched between Tracing paper.)
 - Film
 - Newspaper
 - Cardboard paper

1.7.2 Special Documents

The following kinds of originals are "special". It is possible to scan them, **but the image quality and feed reliability are not guaranteed.**

- (1) The type of original is acceptable, but the thickness and type may not be:
 - Booklets
 - Original with a Hanger
 - Cut and Pasted originals
- (2) These original may not damage the scanner, but these types are NOT recommended:
following ones.
 - Cloth
 - Aluminium Kent Paper

1. 7. 3 “Do Not Scan” Originals

It is impossible to use the following types of originals because they are likely to damage the scanner.

Do not scan the following kinds of original, because you may damage the original or scanner itself!

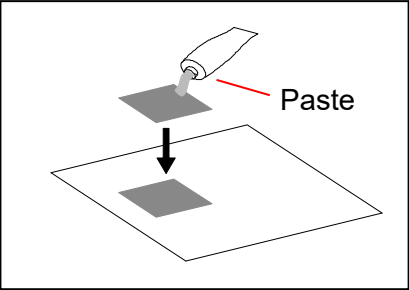
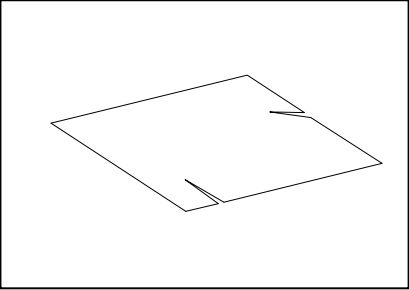
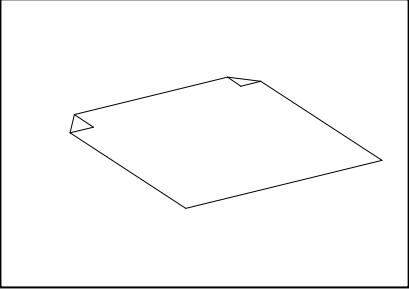
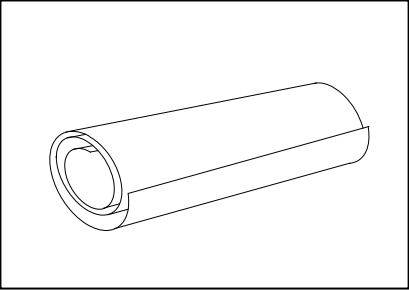
Sticked with paste	 A diagram illustrating the process of sticking a piece of paper. A brush is shown applying a substance labeled "Paste" to a small square on a larger sheet of paper. An arrow points from the brush to the paste, and another arrow points from the paste to the paper.
Torn	 A diagram of a rectangular piece of paper with jagged, irregular edges, representing a torn document.
Folded (Leading edge)	 A diagram of a rectangular piece of paper folded in half, with the leading edge (the edge closest to the scanner) clearly visible.
So much curled (Diameter is smaller than 50mm.)	 A diagram of a piece of paper rolled into a tight cylinder, with the diameter of the roll being significantly smaller than 50mm.

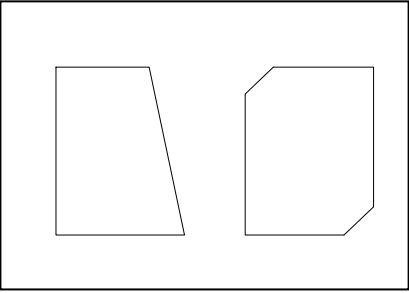
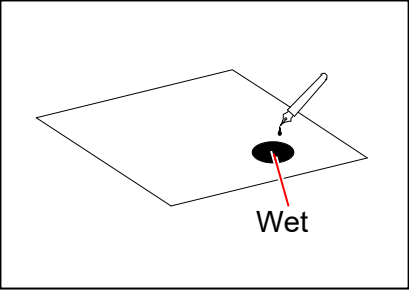
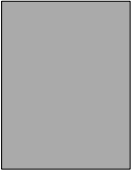
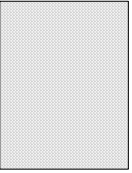
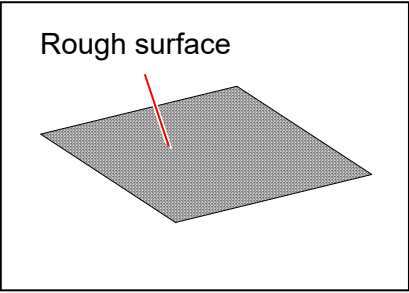
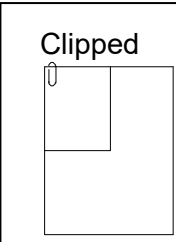
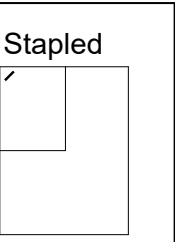
<p>Not square</p>	
<p>Wet image</p>	
<p>Made of metal or fabric</p>	<div style="display: flex; justify-content: space-around; align-items: center;"> <div style="text-align: center;"> <p>Metal</p>  </div> <div style="text-align: center;"> <p>Fabric</p>  </div> </div>
<p>Rough surface (Carbon paper for example)</p>	<p>Rough surface</p> 
<p>Clipped or stapled</p>	<div style="display: flex; justify-content: space-around; align-items: center;"> <div style="text-align: center;"> <p>Clipped</p>  </div> <div style="text-align: center;"> <p>Stapled</p>  </div> </div>

The following kinds of originals can be read with using a carrier sheet.

However, the image quality and feed reliability are not guaranteed.

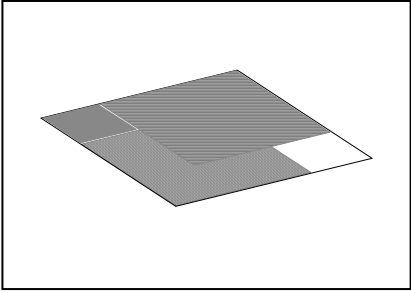
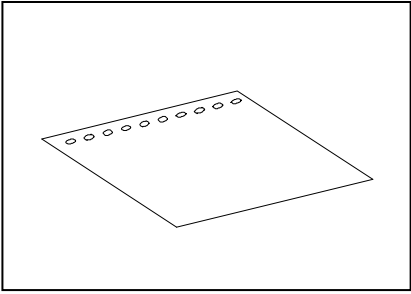
Patched	
Punched	

Chapter 2

Basic Operations

	page
2.1 Turning on the Printer	2- 2
2.2 Turning off the Printer	2- 4
2.3 Replacing the Roll Media	2- 6
2.4 Placing Cut Sheet Media	2-13
2.5 Toner Supply	2-14
2.6 Replacing Toner Receptacle	2-21
2.7 Copying (MFP Model)	2-28
2.8 Stop of Scan or Copy (MFP Model)	2-30

2. 1 Turning on the Printer

1. Plug the Printer to an exclusive wall outlet.

WARNING

Please confirm the outlet satisfies the following condition before plugging the Printer into.

Europe; 220V to 240V plus 10% or minus 10%, 50/60Hz, 16A or higher
North America; 208V plus 10% or minus 10%, 50/60Hz, 16A or higher

2. Press “|” side of the Power Switch.

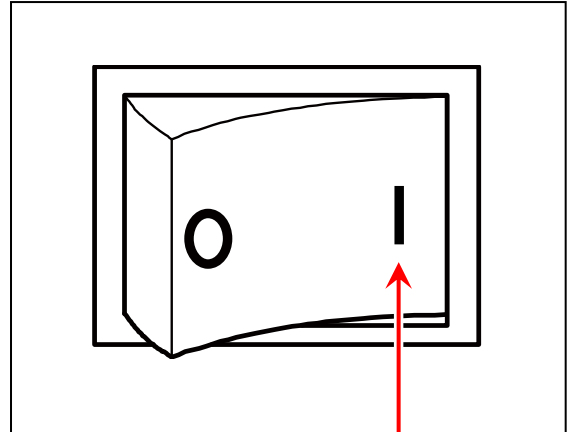

Press this side

3. The status indicator on the upper right of the printer is blinking and the warming-up is started.



NOTE

The machine does not operate at all if the circuit breaker is turned off.
Flip up the circuit breaker switch to turn on the power supply.

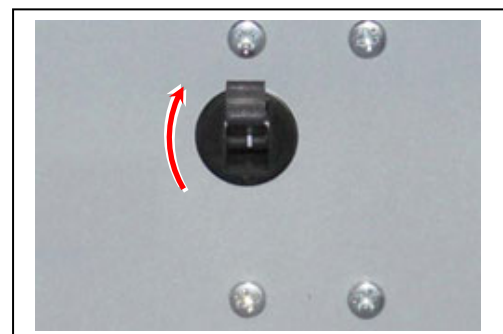

- The Printer will get ready about 6 minutes after turning on.
The Status Indicator stops blinking and lights green when ready.
Make a copy or print from outer devices.

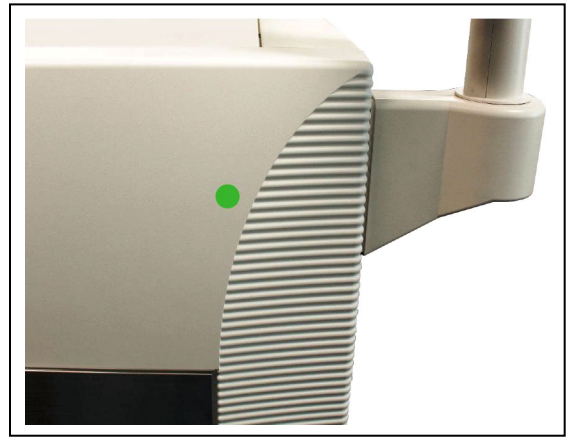
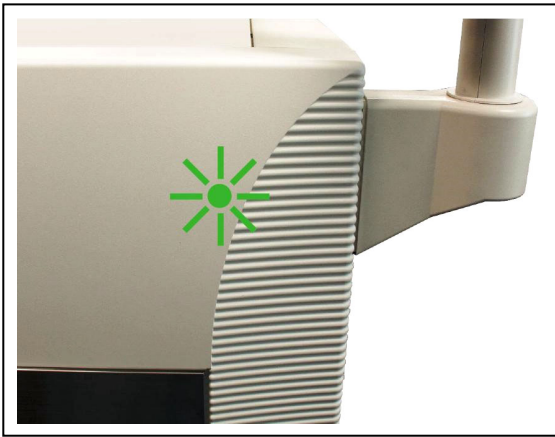

2. 2 Turning off the Printer

1. Press “O” side of the Power Switch.

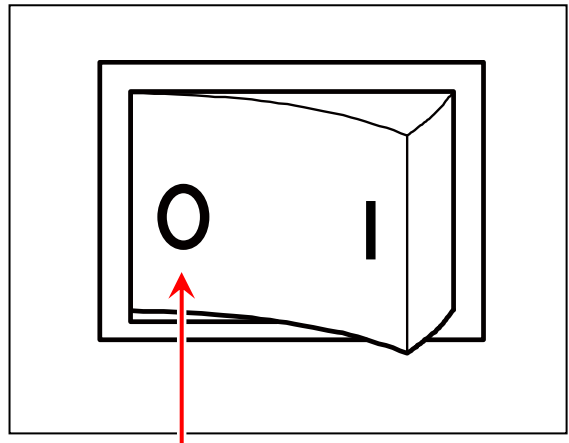

Press this side

2. The Status Indicator light purple while the embedded controller unit is shutting down. It will turn off in few minutes.

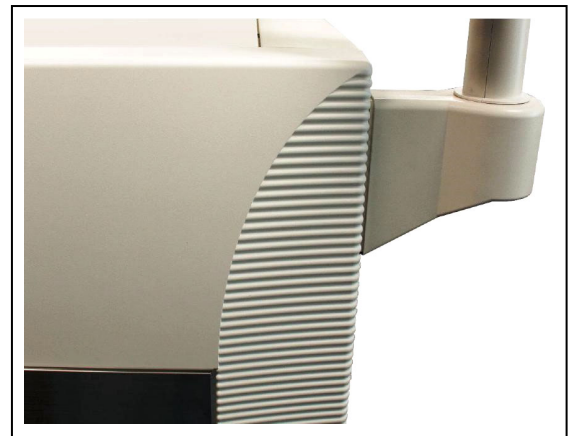
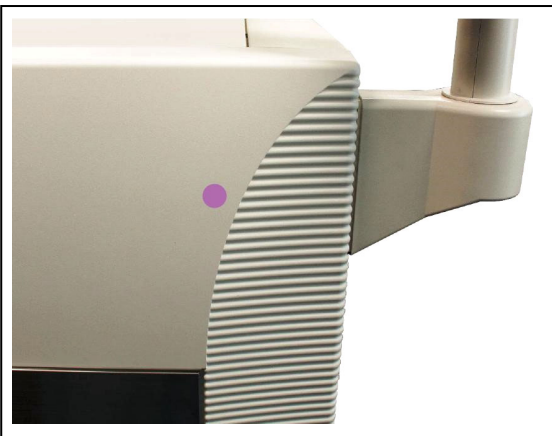

NOTE

The controller unit starts shutdown process after turning off the Printer, and it will take about 1 minute until complete shut down. Do not unplug the Printer from the outlet for about 1 minute after turning off therefore. The controller unit may be broken if the Printer is unplugged before the completion of shut down process.



3. If you completely shut the power supply due to a long vacation or the machine's transport, turn off the circuit breaker and then remove the power cable from the machine.



2.3 Replacing the Roll Media

UI displays a sign of “Roll Replacement” when the used roll media gets empty. Follow the later procedure to load a new roll media.

1. Open the Roll Deck (1) that has empty roll media.
With catching the Flanges (2) on both sides, lift and remove the core of roll (3).

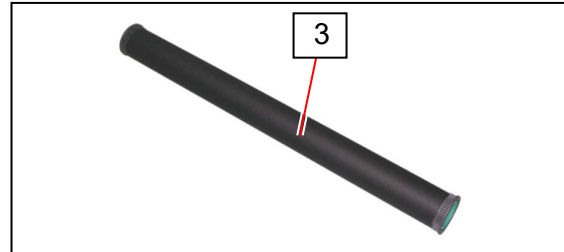
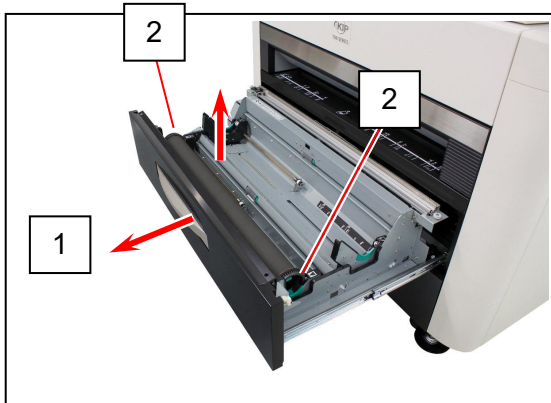

Reference

When a roll paper, without terminated by tape fixing to its core, is set to Roll 1 and has an event of roll empty, the remaining last portion of the sheet from the roll would stay in the Roll Deck as shown in the following picture. This is as engineered. Please remove the portion and then replace the roll media.

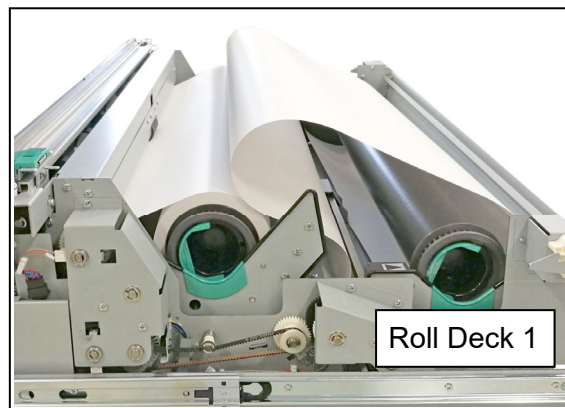

NOTE

Please do not touch the cutter Blade on the back of the Roll Deck Drawer.

2. Pull the green lever (4) on each Flange (2), which releases the core of roll (3). Remove both Flanges (2).

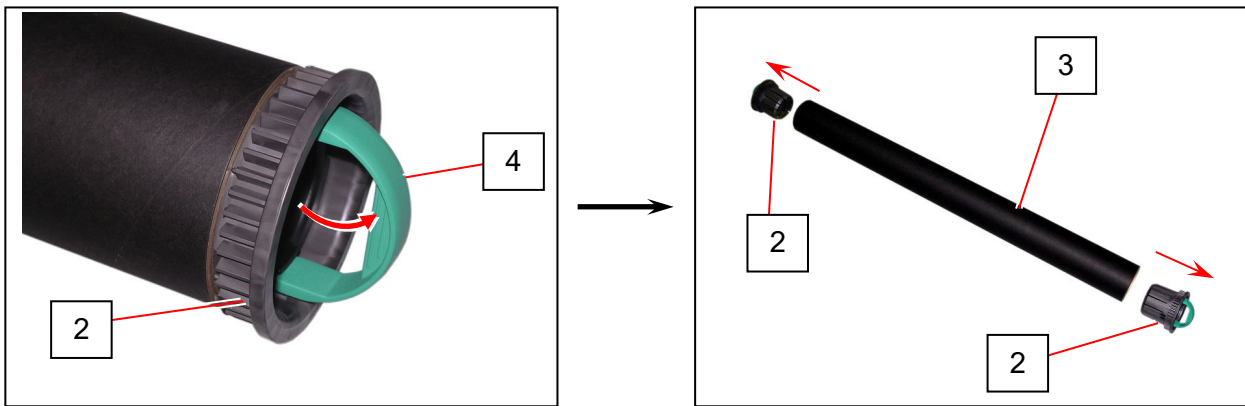

3. With sliding the Slide Guides (5) left and right by hand, align them to the width guide lines that match the width of actual media to be loaded. (Sliding either left or right one of 2 Side Guides also moves the other one by the same amount.)

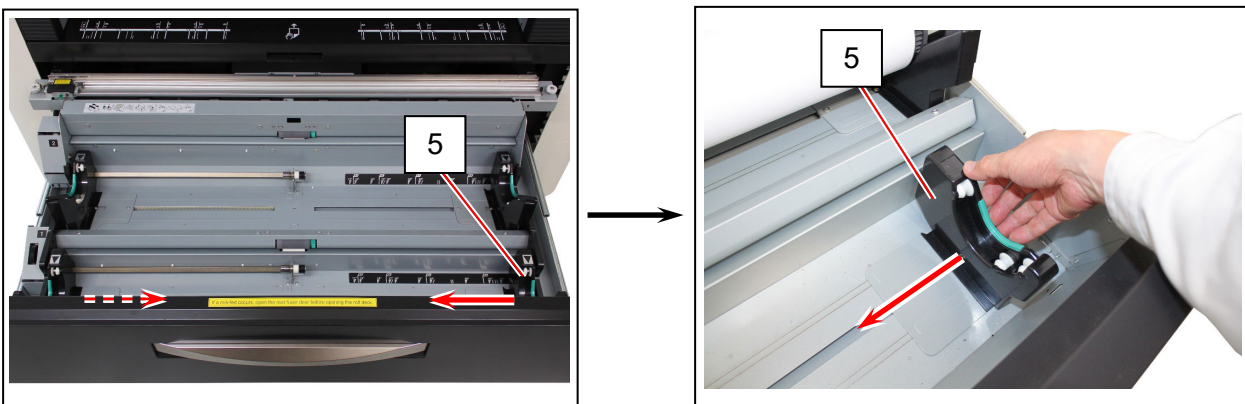

4. Insert both Flanges (2) deep into the core of new roll media until they stop.

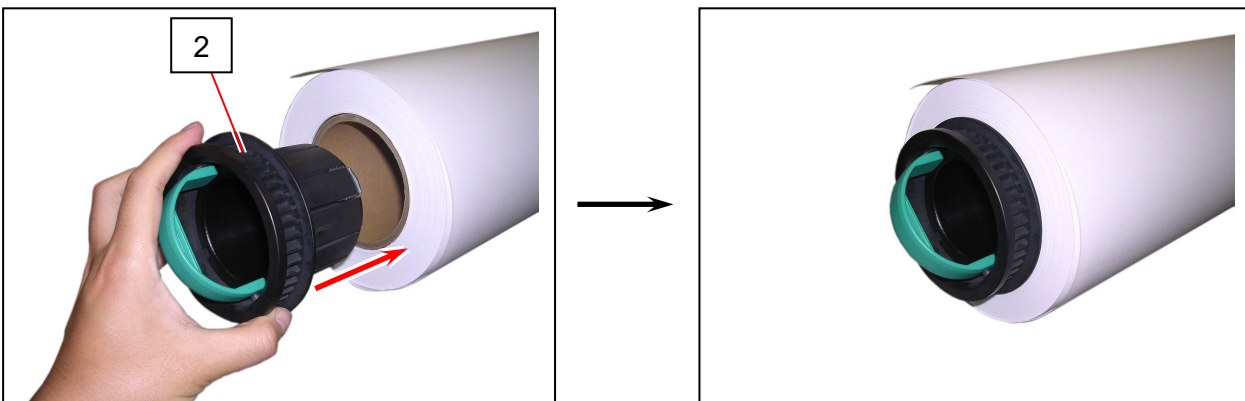

(See next page for more explanation)

NOTE

(1) Insert Flanges (2) deep enough into the core of roll media until their inside rims surely touch the side face of roll media with having no gap.

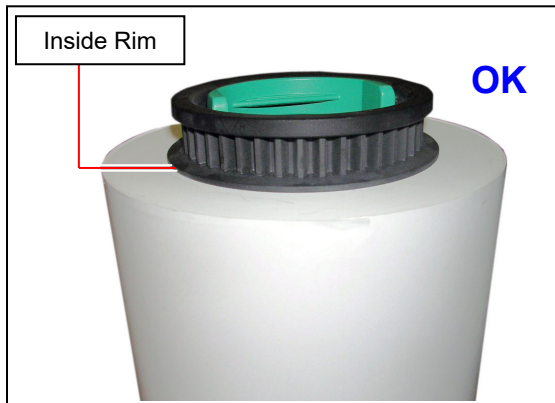

Correct: Fully inserted

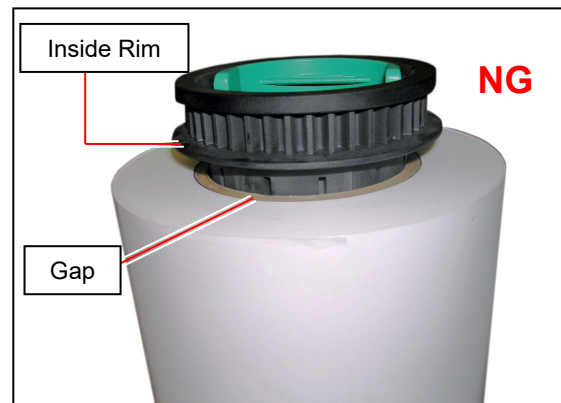

Incorrect: There is gap

(2) Be careful not to be harmed by the saw-toothed edge (6) when handling the Flanges (2).

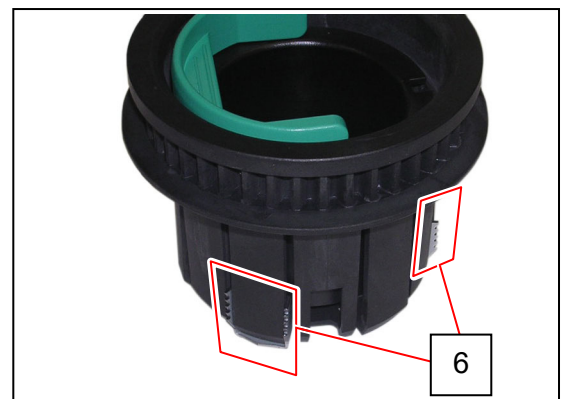

5. Turn down the lever (4) in either way until they completely stop, which lets the Flange to surely hold the roll media.

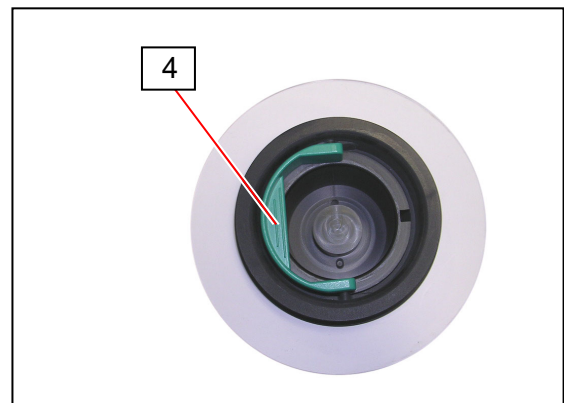
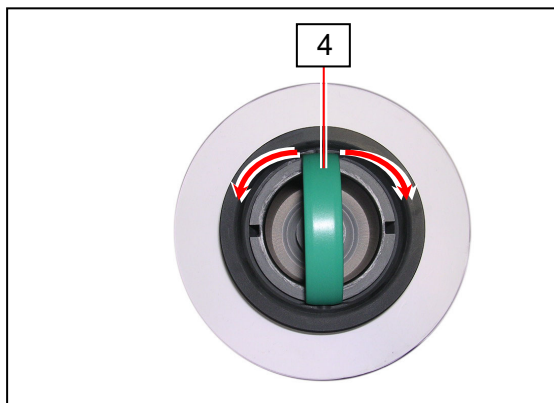

6. Fit both Flanges correctly into both Slide Guides (5) in the roll deck.

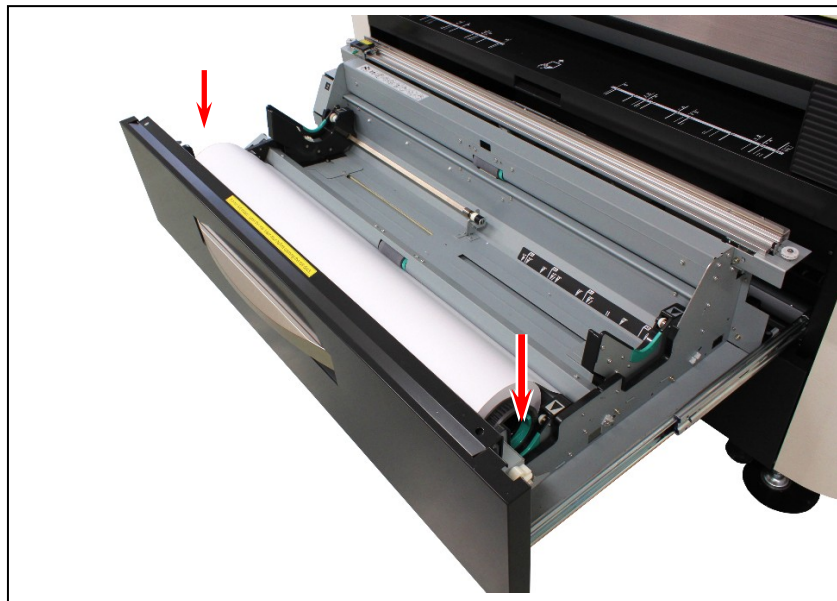
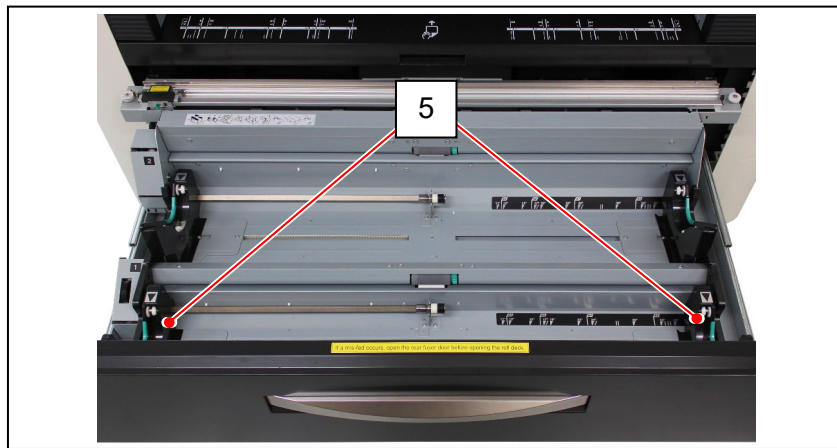

(See next page for more explanation)

! NOTE

(1) Note the position of leading edge. It should be on the top side when directed to the media feeding path.

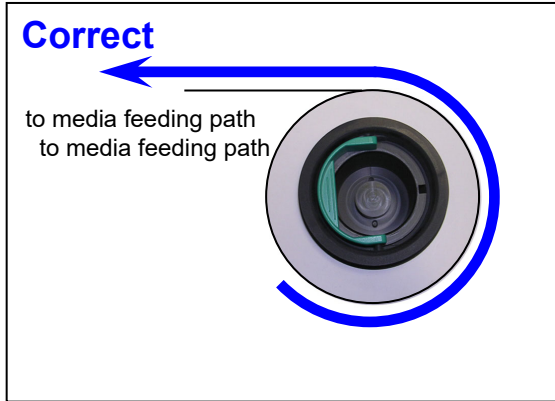

Correct : Leading edge is on top side

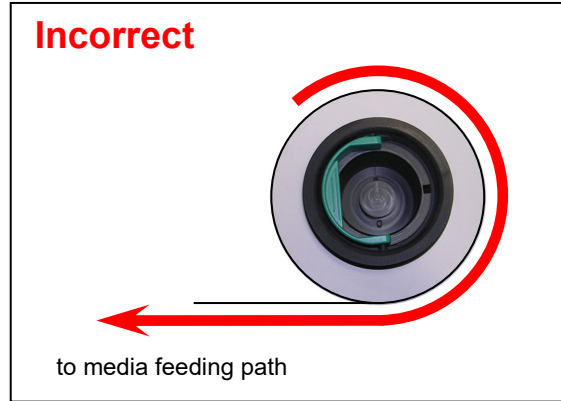

Incorrect : Leading edge is on bottom side

(2) The outside rim (7) of the Flange must be aligned with the tip of black triangle (8) for correct gear engagement. If not, the Flange may come off from correct position and may result in incorrect media feeding.

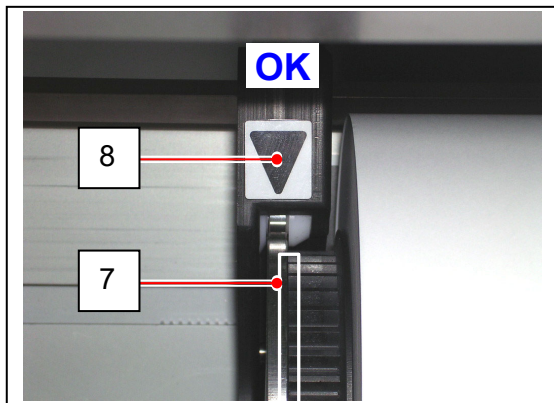

Correct

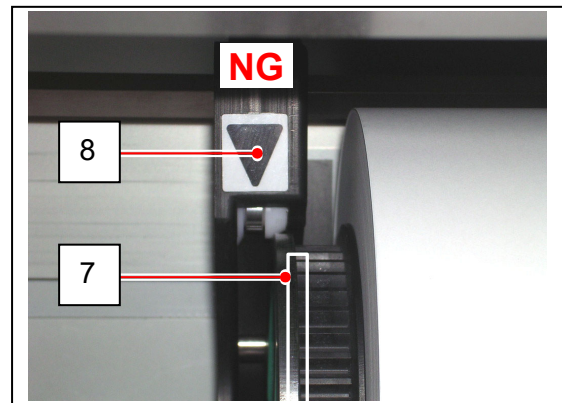

Wrong

7. Insert the leading edge under the corresponding Feed Roller (10), and then turn the Feed Knob (11) to forward the roll media.

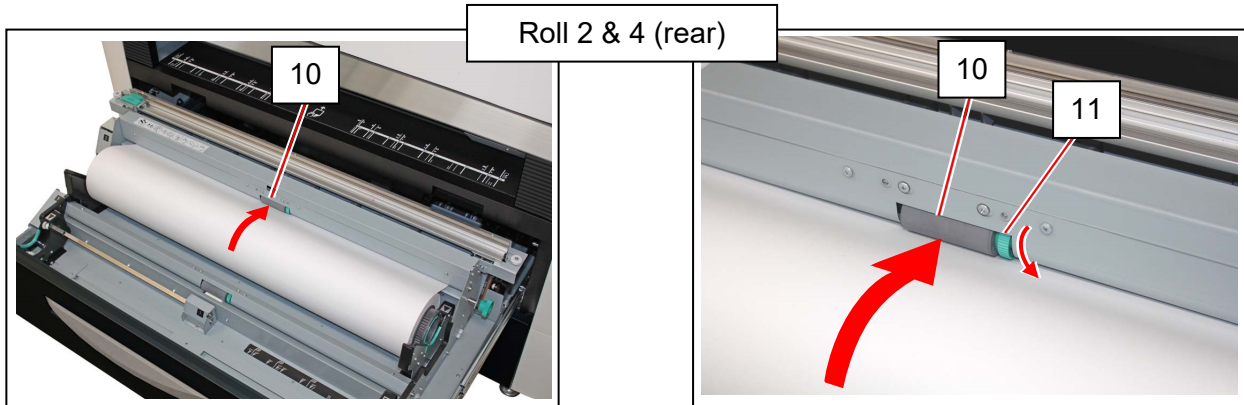
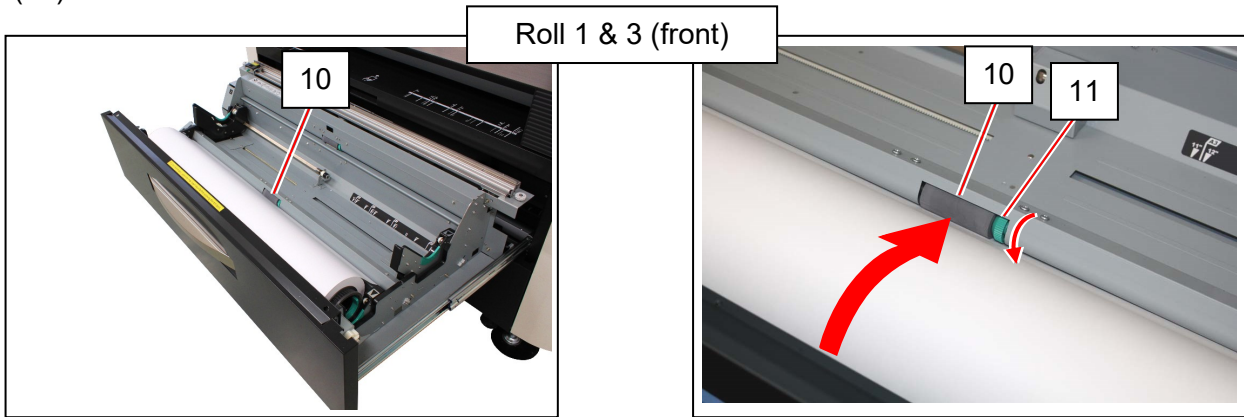

8. Push the Roll Deck (1) back in.

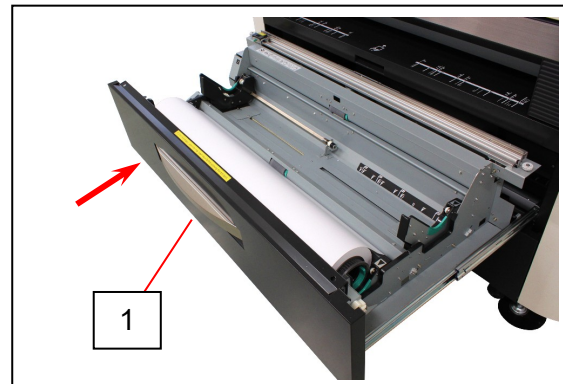

NOTE

- (1) Surely close the Roll Deck until it is locked. A paper jam may occur if not locked perfectly.
- (2) Be careful not to catch your finger in between Roll Deck drawers.

10. Define the media information (media type and width) with using the touch screen. If necessary, press the Trim Button  (Scissors icon) or [Trim all] button. Press [OK].



NOTE

- (1) Please set correct type and width settings. Incorrect settings would lead unexpected print results.
- (2) If no roll media is installed in the Roll Deck at all, the printer status does not get "Ready" and the touch screen shows "Attention Required". Follow the instruction in this section to set a roll media properly, and the status will get "Ready". If still "Attention Required" remains, contact your local service representative.

Reference

The printer will take a programmed internal cleaning process when a roll media is switched to another. Please wait until the cleaning finishes and the status gets "Ready".

2. 4 Placing Cut Sheet Media

There are several size markings on the Manual Table which indicate possible feed positions. Place a cut sheet in a required size on the table between its concerning size markings then insert it into the Manual Feeder.

When the leading edge touches the feeding roller, the machine automatically carries and sets the sheet at the proper position.



NOTE

- (1) As a curly cut sheet will cause a mis-feed, straighten the sheet as far as possible before printing. And set the sheet in “curled down” direction as a mis-feed can be avoided. “Curled up” sheets tend to result in a mis-feed.



Please do not use “curled up” sheet.

- (2) Setting a cut sheet to the Manual Feeder while printing may cause a paper jam. Be sure to check the printer is idle (not processing a print job) before setting a cut sheet.

2.5 Toner Supply

Reference

When the toner level gets “near to empty”, the screen indicates “Replace Toner”. Please add the requested genuine toner as instructed in the screen. You can add the toner while the printer is in operation.

You have two options when “Replace Toner” message is indicated. One is to add the toner at the time. Another is to cancel this message and add the toner later.

- A) If you wish to add the toner right then, please add the toner with referring to the instructions on the later pages, and then press [Toner Added] button in the screen.
- B) If you do not add the toner at this time but will do it any time later, please press [Dismiss] button to temporarily skip the “Replace Toner” message. The printer will continue printing even if the toner level is in “near to empty” condition. Please note that the toner shortly runs out and the printer stops printing with showing “Replace Toner”. (This point of time the printer keeps waiting until the requested toner is added)
Please add the toner with referring to the instructions on the later pages, and then press [Toner Added] button in the screen.

NOTE

The printer may stop printing without an advance notice “Replace Toner”. This situation may possibly occur when printing with a heavy media by the slow print speed.

1. Open the Toner Cover (1).

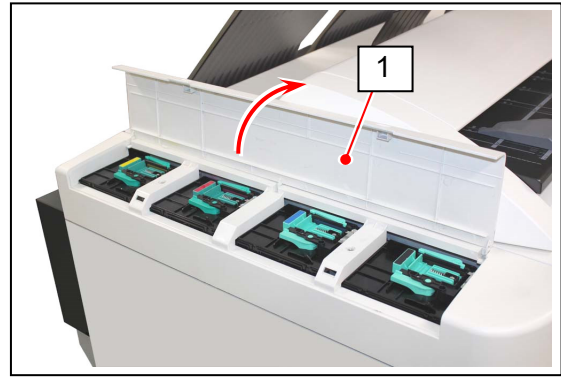

2. Gently shake a new Toner Bottle (2) well to loosen the powders inside the bottle.

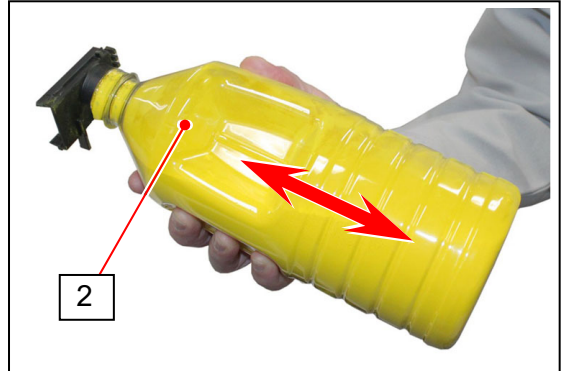

! NOTE

To make the toner powder smoothly leave from the Toner Bottle on the next step, please ensure the followings.

- After shaking the bottle, supply the toner to the machine without a pause.
- Do not shake the bottle sharply. Doing so may the toner powder get pressed and compacted.

3. Fit the supply hole on the Toner Bottle (3) with the set position of on the Toner Hopper (4). Once the supply hole on the Toner Bottle (3) fits the receipt on the machine side (4) correctly, the Lever will automatically catches the Toner Bottle as shown below.

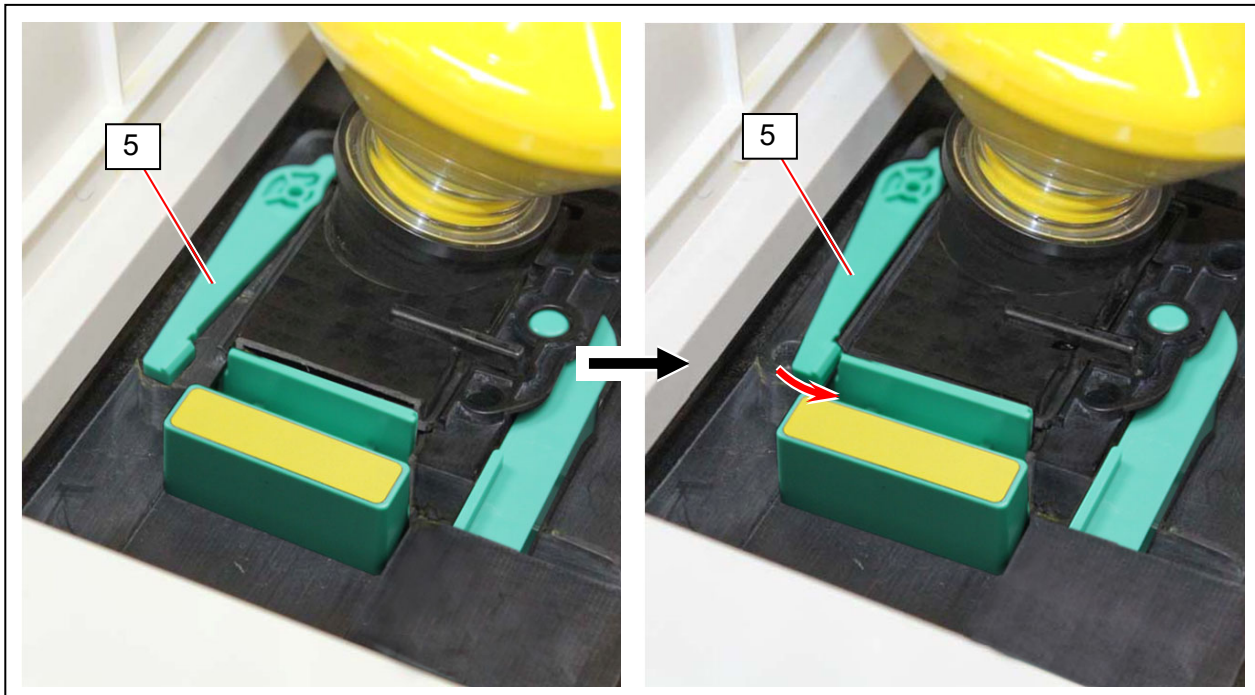
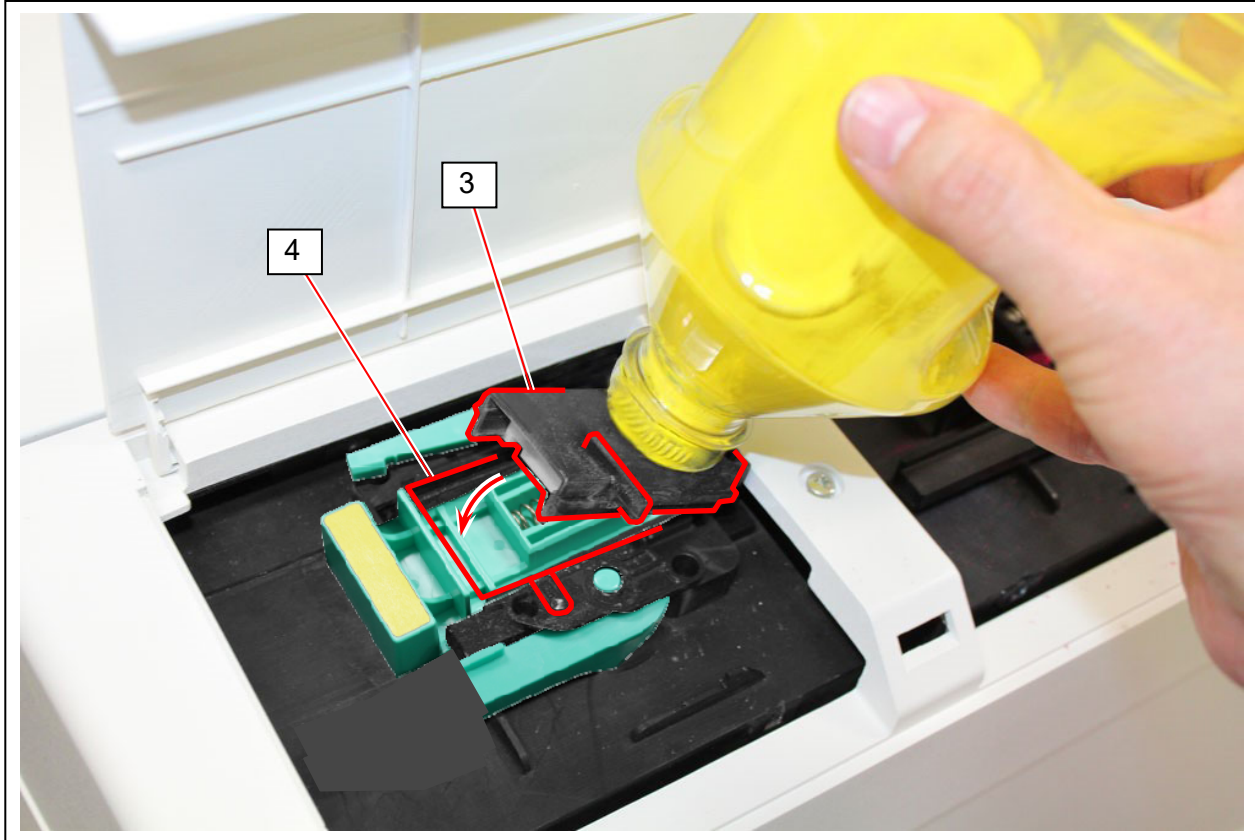

4. Fit the Toner Bottle so that the tab part (6) can push the pin (7).
Turn the Lever (8) to lock the Toner bottle with the Toner Hopper.

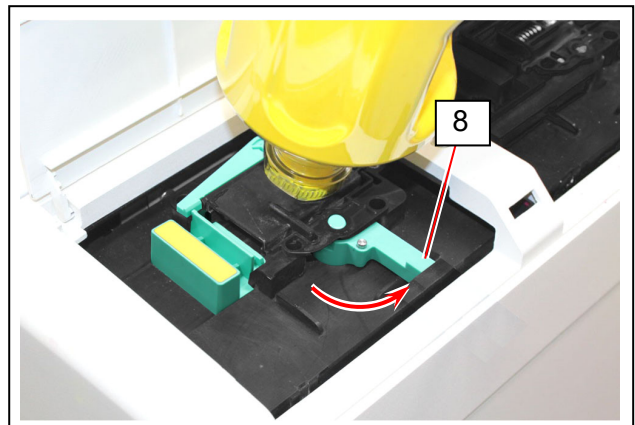
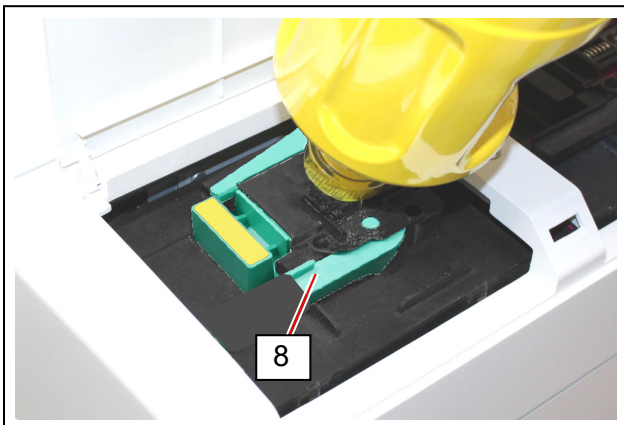
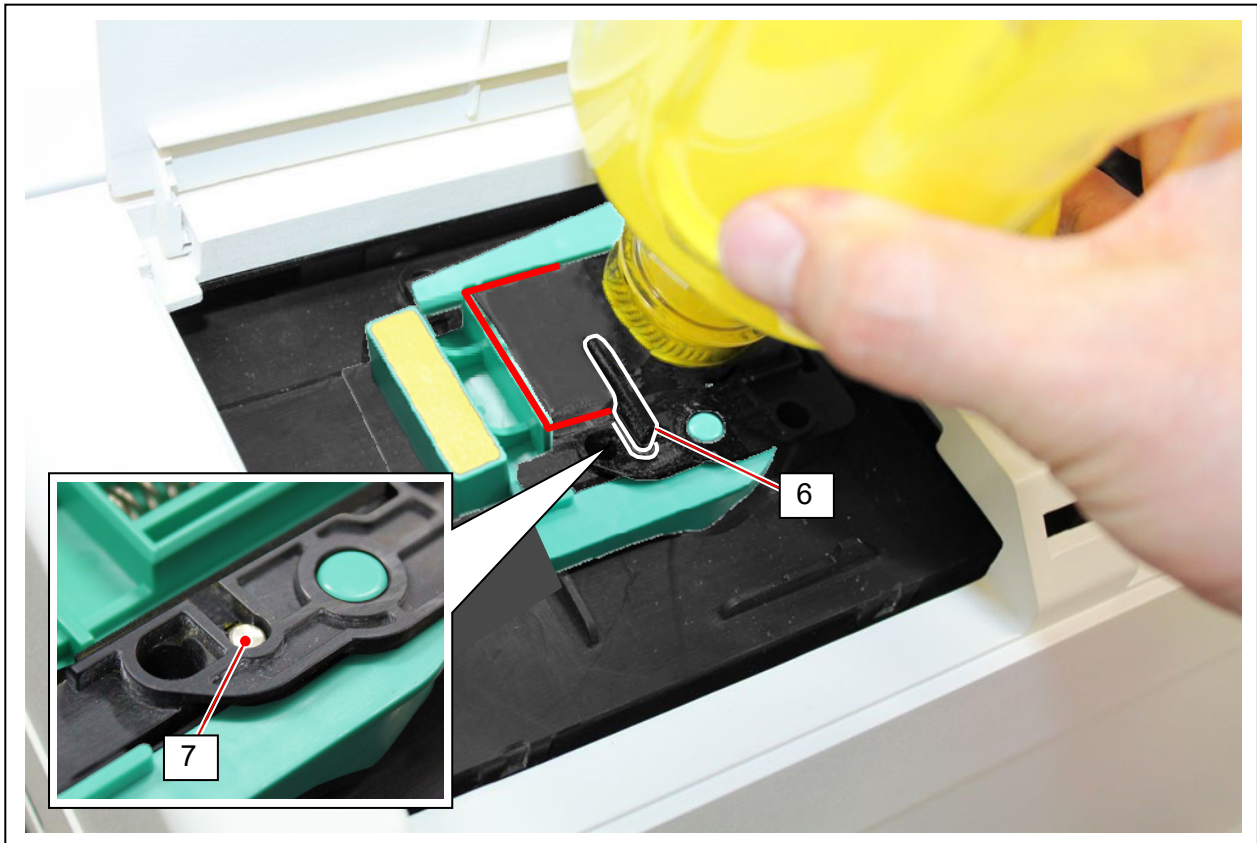

5. Move the Slide Lever (9) to the arrow direction. Now the toner powder inside the bottle falls in the Toner Hopper. After the most amounts of the toner falls, turn the Toner Bottle body 3 revolutions so that the retaining toner in the Toner bottle can fall.

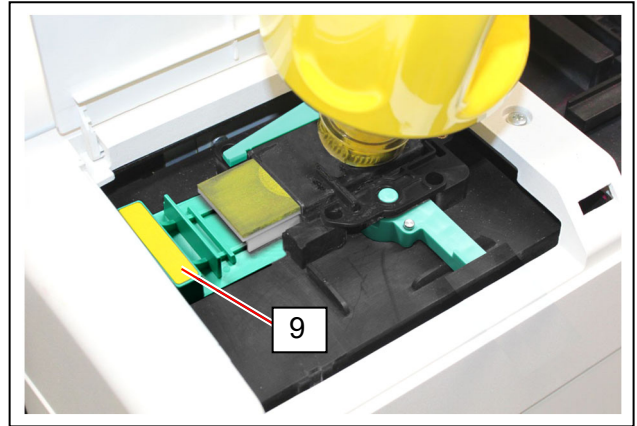
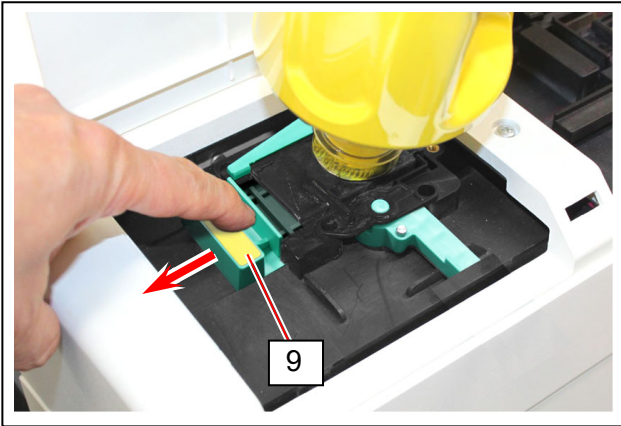

⚠ NOTE

To use up the toner powder left in the bottle, turn the bottle to either direction, by 3 revolutions. If you apply strong force to the bottle, the toner may spill out.

- Do not rap the Toner Bottle hard.
- Do not twist the Toner Bottle.
- Do not squash the Toner Bottle.

6. When the toner supply to the Toner Hopper is finished, move the slide lever (9) back until it stops at the line (A). (May feel slight resilience when the slide lever (9) reaches the end)

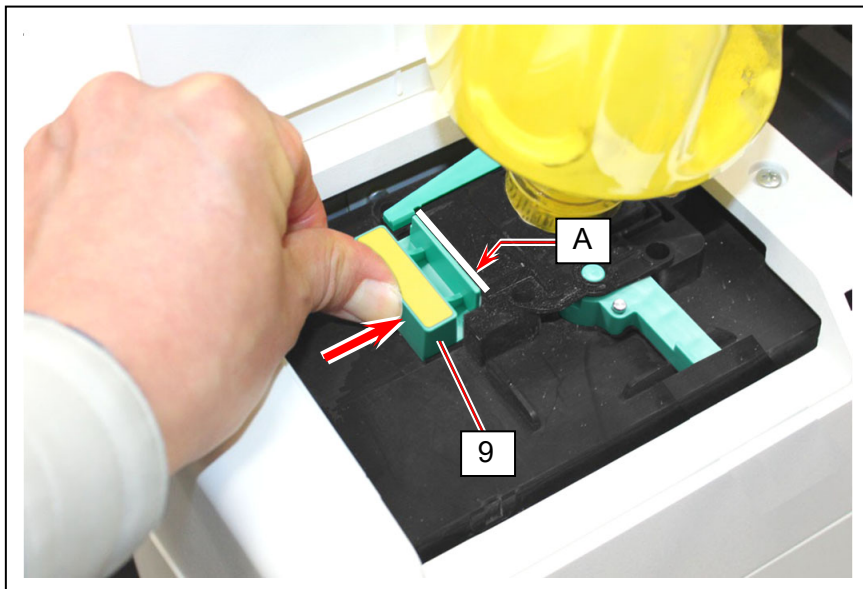

7. Turn the lever (8) to the original position.

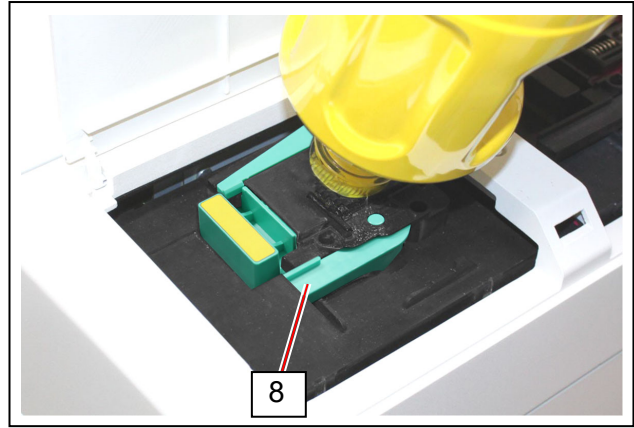
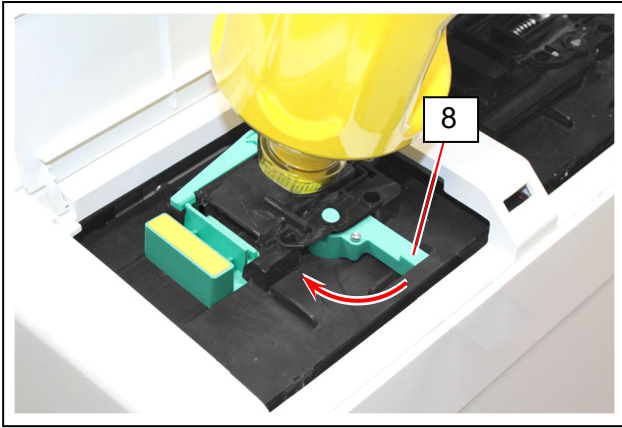

8. With pushing the release lever (9) to the direction of the arrow, detach the Toner Bottle.

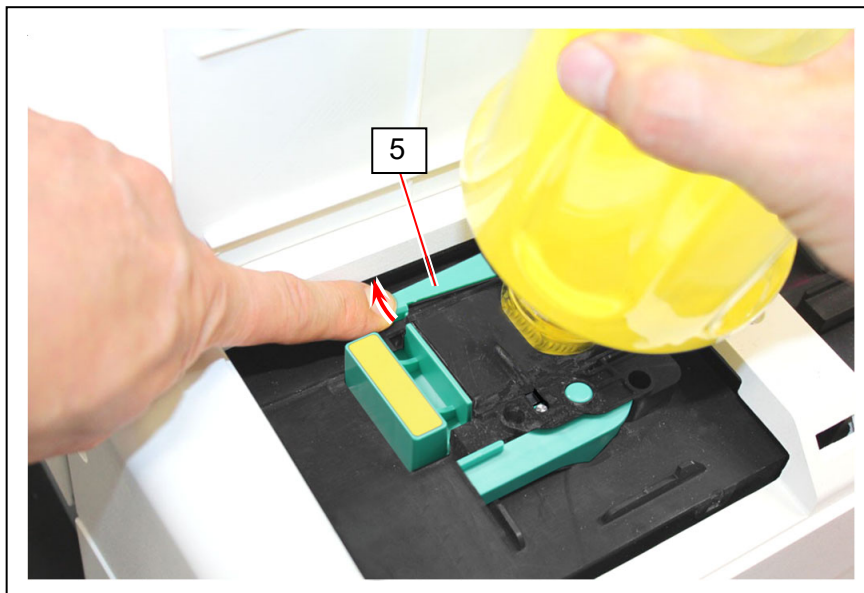

⚠ NOTE

The full capacity of the toner hopper is one toner bottle.
Do not supply the toner more than the above.

⚠ WARNING

There is combustible powder in the toner cartridge.
Do not burn up the used toner cartridge.

9. Press the Toner Recovery button in the touch UI. The printer will properly supply the toner to the imaging section and takes necessary toner refilling actions automatically.

- The printer goes into “warm up” while processing toner supply. Please wait until the supply is completed.
- The printer gets “ready” after the toner refilling completes.

2. 6 Replacing Toner Receptacle

When the Toner Receptacle is full, the UI screen shows “Cartridge Full.”
The printer does not restart operations until the Toner Receptacle is properly replaced.



1. Assemble the Toner Receptacle as follows.

Reference

(1) It is easier to assemble by pre-folding beforehand on the fold lines.

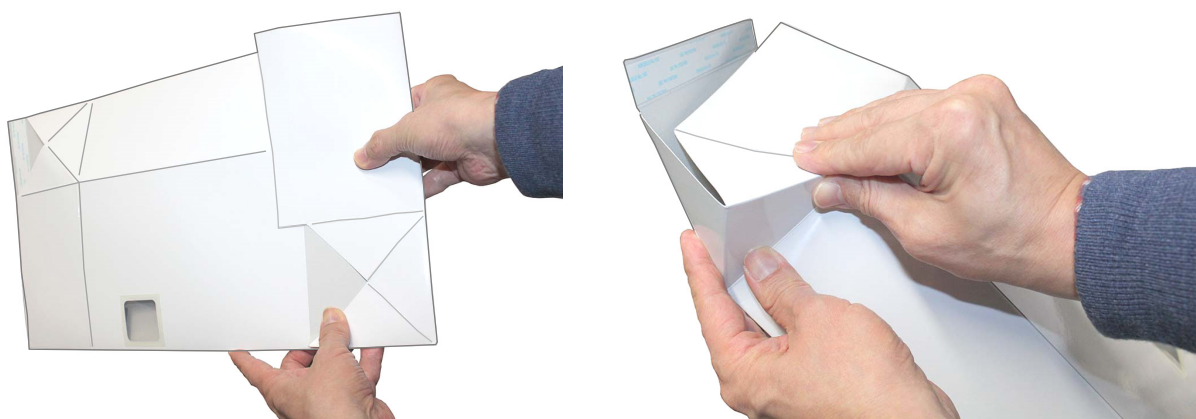

(2) It is easier to assemble by starting to fold from the side with the toner dropping port.



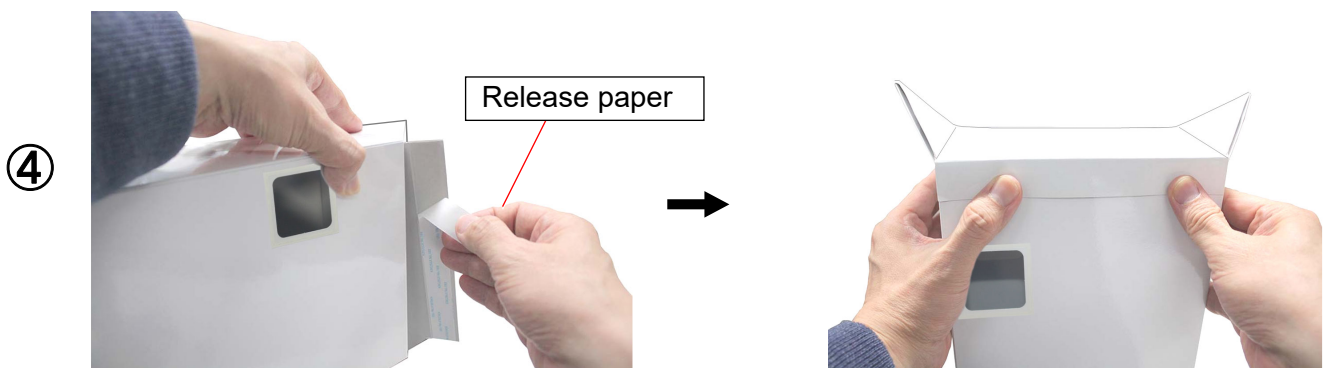
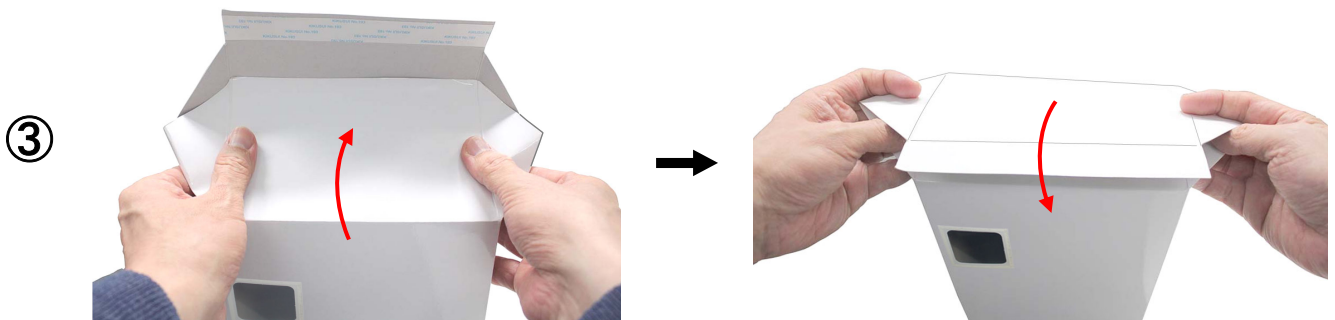
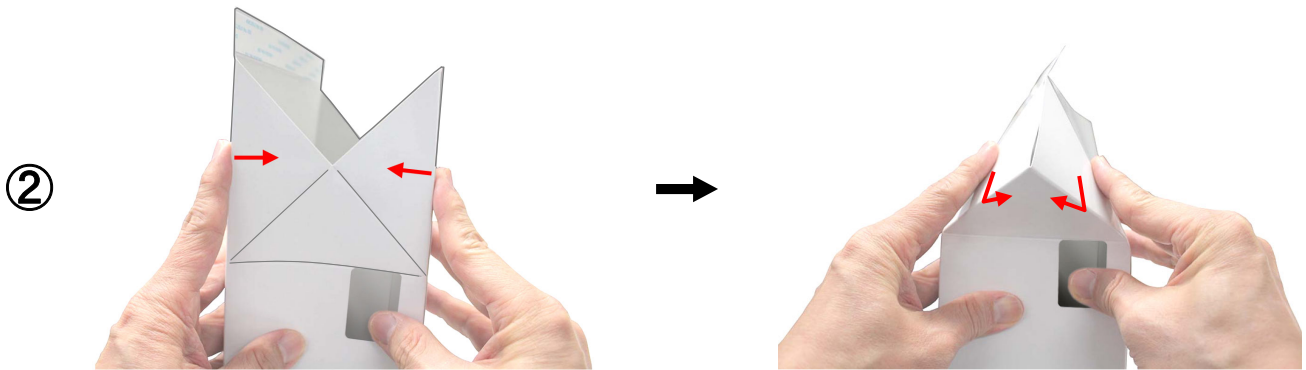
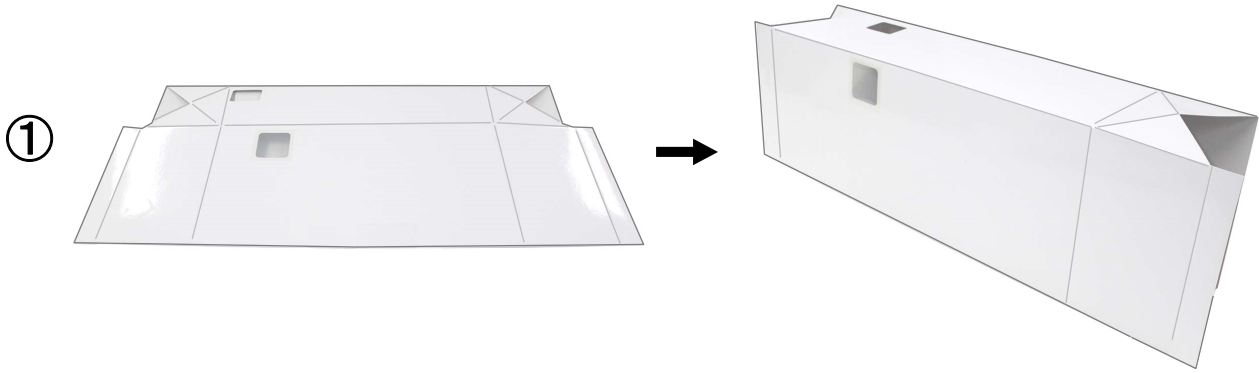

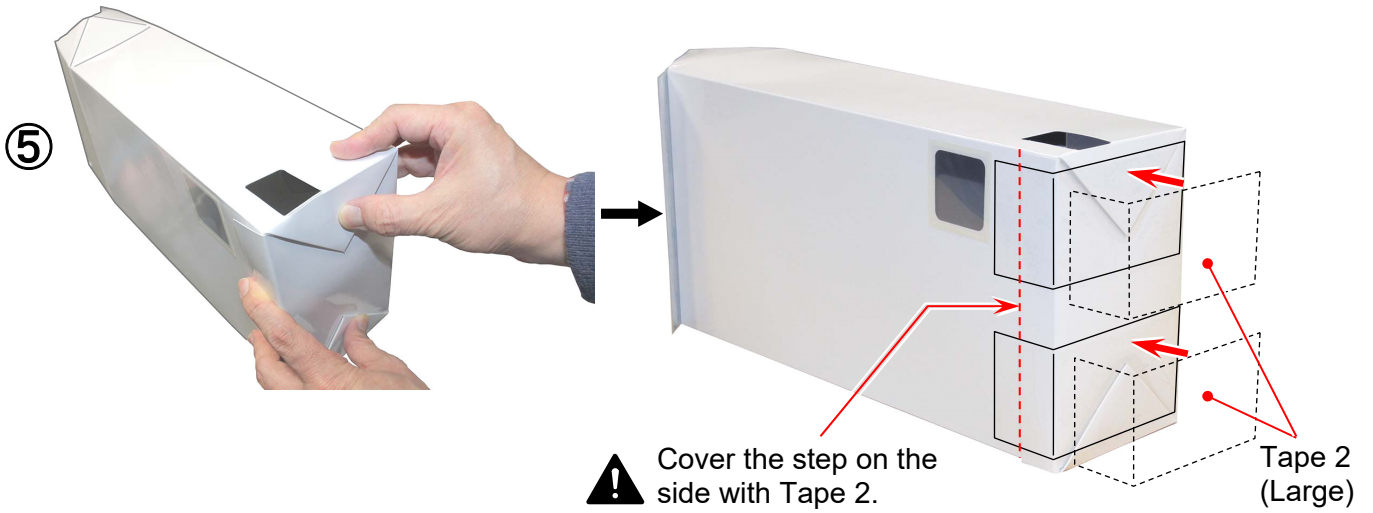

! NOTE

Apply the Tape 2 in L-shape to cover the step on the side. Otherwise the step might get caught by the toner receptacle shutter part to prevent from smooth removal of the box.

⑥ Assemble the other side in the same way (Step 2 to Step 5).

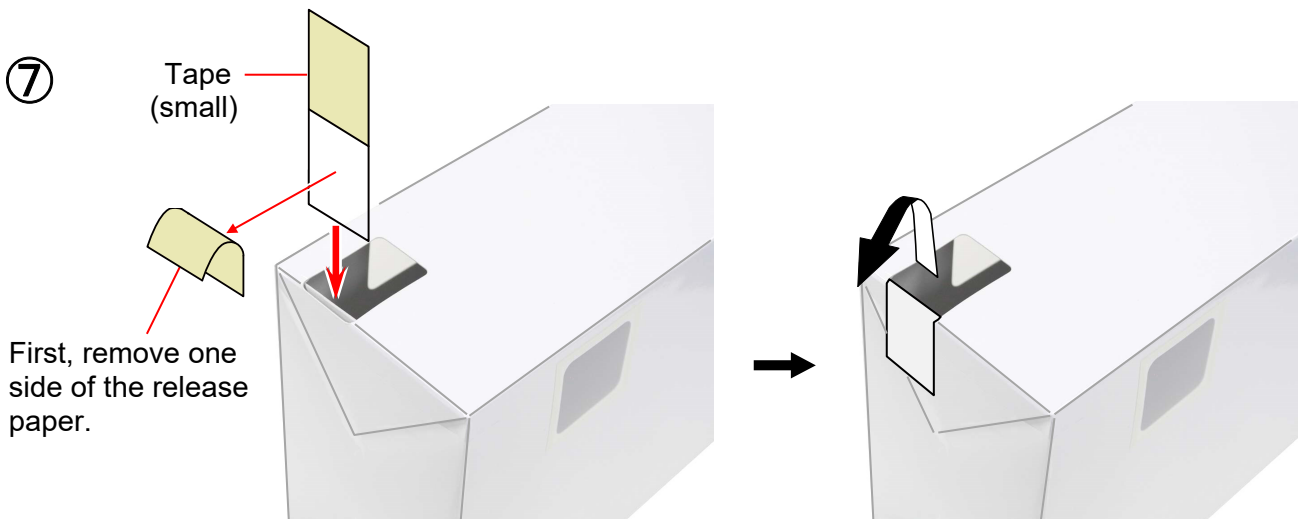
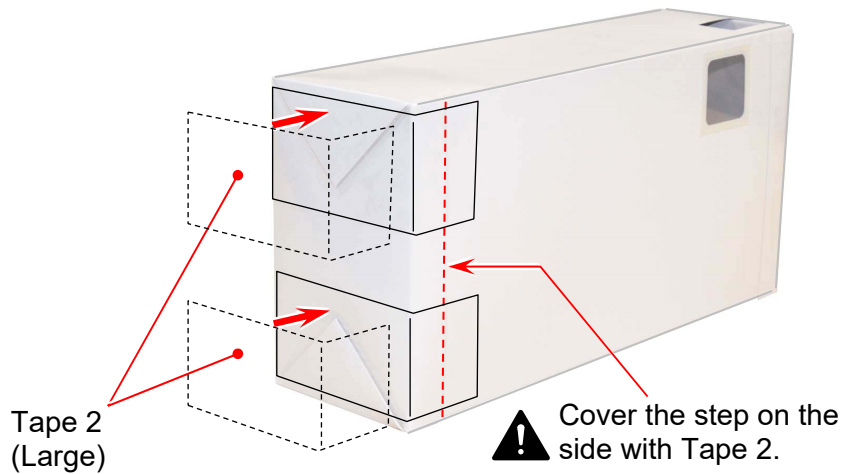

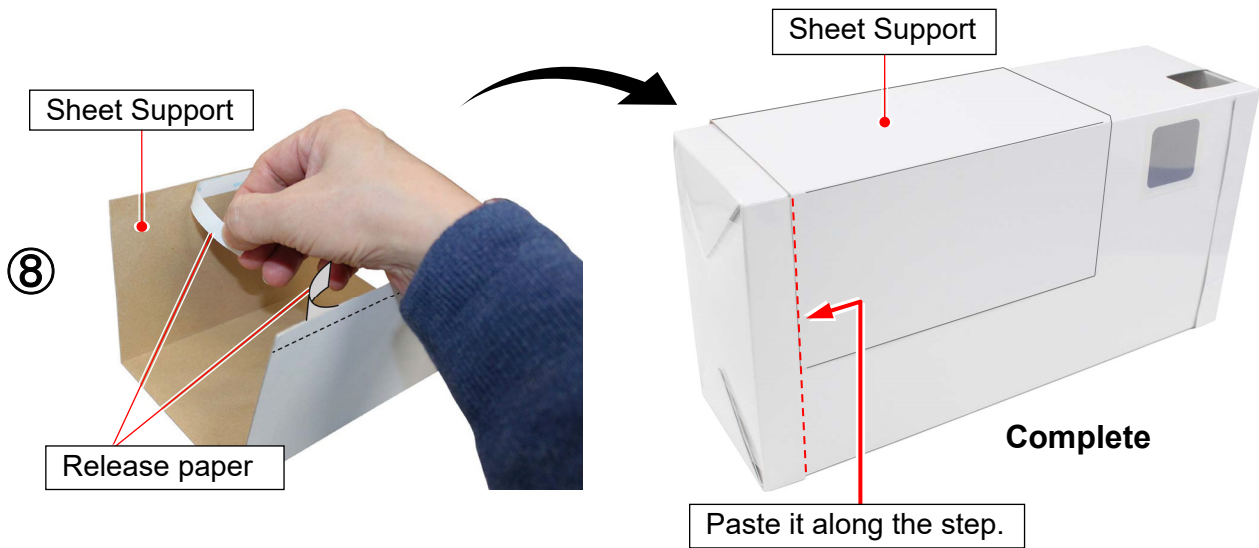

2. Open the Left Door (1).

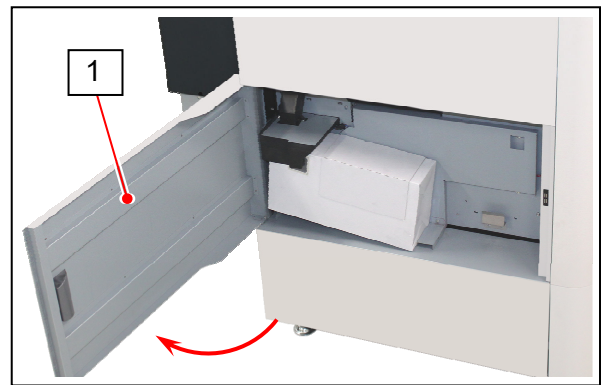

3. With holding the Toner Receptacle (2) with your hands, bring it up and move it frontward to remove from the machine.

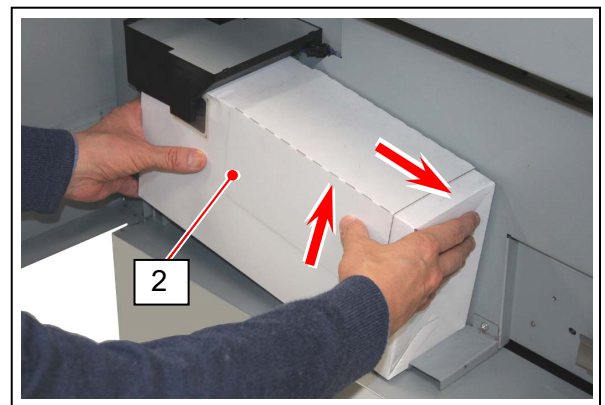

4. Apply the Tape 2 (Large) (3) to close the opening of the Toner Receptacle, which is included in the Toner Receptacle Kit.

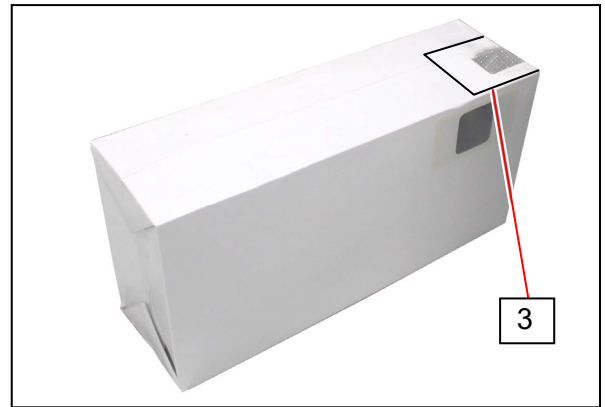

⚠ WARNING

The toner will explode if thrown into a fire.

⚠ NOTE

- (1) Do not handle the Toner Receptacle roughly. Otherwise the toner will come out from its open hole.
- (2) The Toner Receptacle should be discarded according to your local regulations.

5. Set the new Toner Receptacle (4) back in the original position. See the following NOTE.

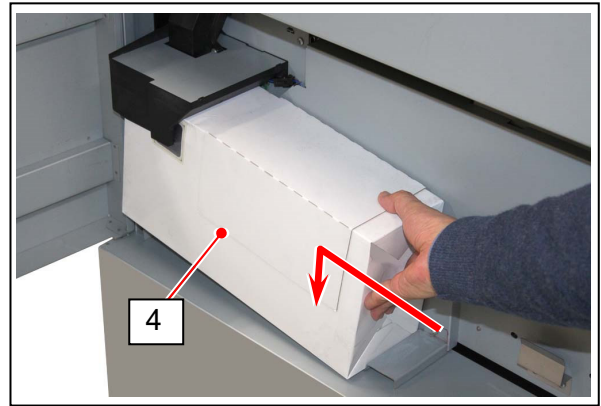

⚠ NOTE

(1) Place the bottom corner of the box at the inside of the positioning step (5).

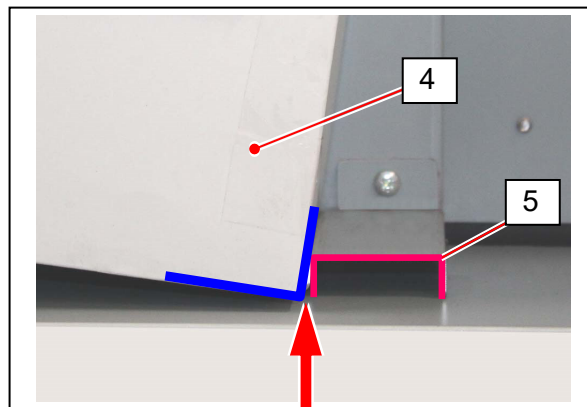

(2) Make sure the clear film windows (6) is not dirty.

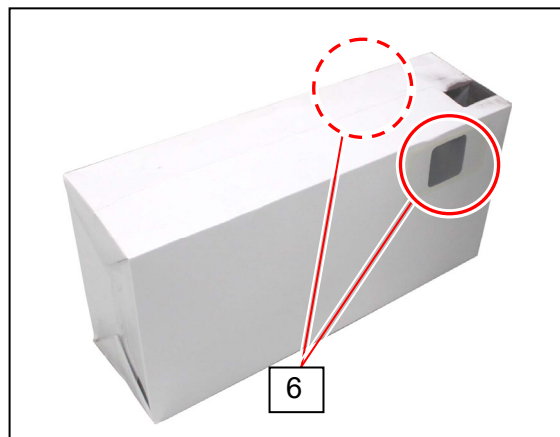

6. Close the Left Door (1).

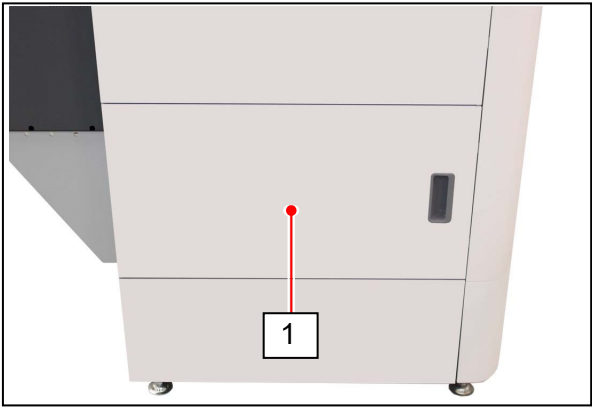

2.7 Copying (MFP Model)

For detailed information to make a copy, please refer to the "GUIDES" in the UI Home screen as well.

1. Press [COPY] in UI Home screen.

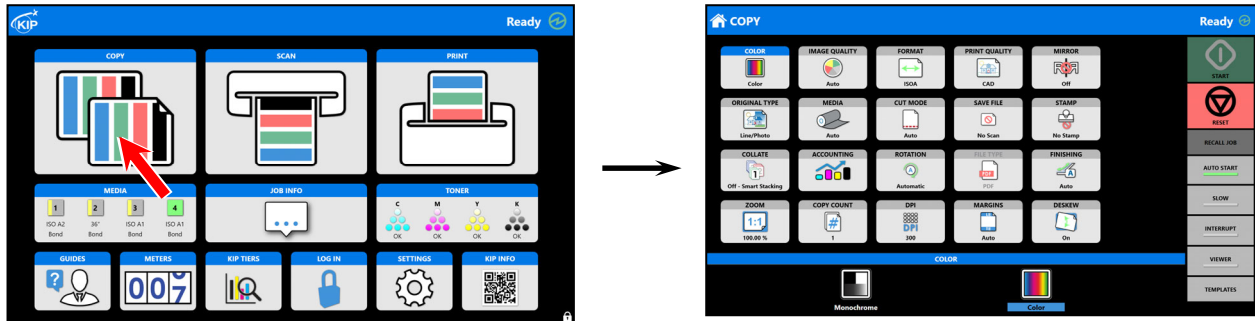

The screens may vary depending on your system configuration.
(Shown with available options)

2. There are several size markings on Original Table which indicate possible feed positions. Line up Original Guides (1) with the proper markings according to the original width.

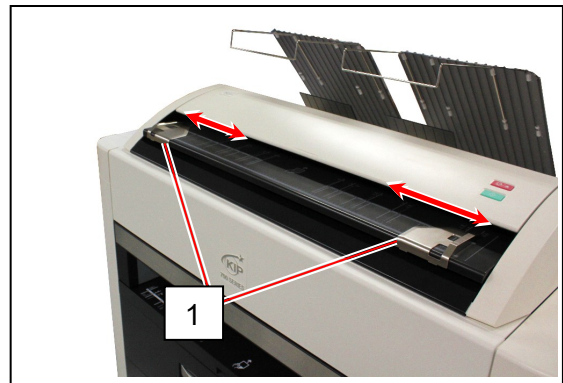
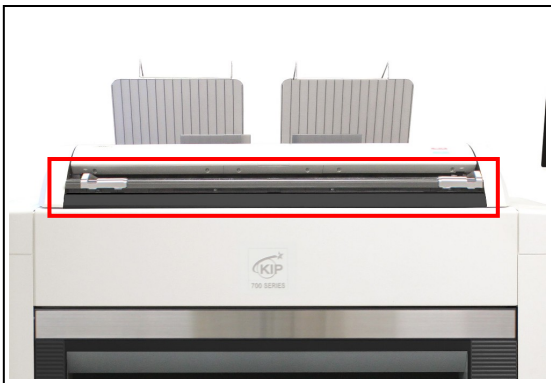

3. Place the original on the Original Table with face up. Then insert it under the Scanner Unit along with Original Guides. When the leading edge touches the original feeding roller, the machine automatically carries and sets the original at the proper position.



4. The Scanner Unit will start the copy process.

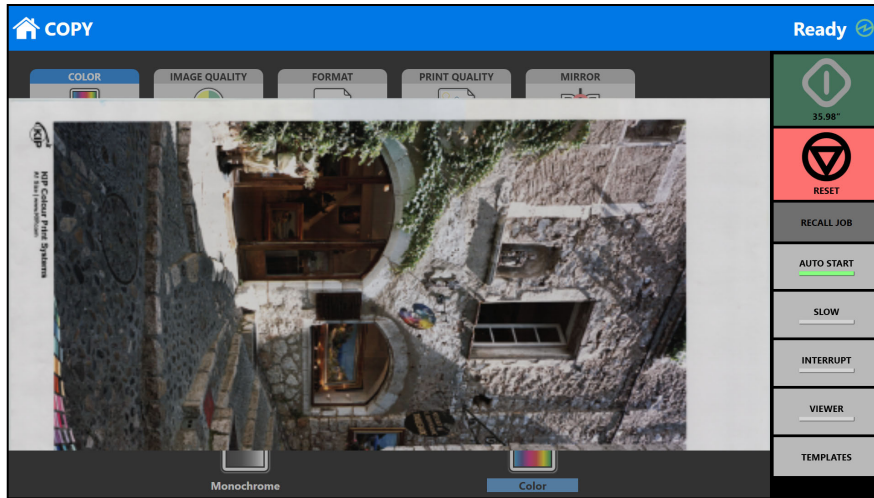

Reference

Pressing START button may be required to start the scan according to the scanner's controller software. For further details of "Auto Start", see the software's document.

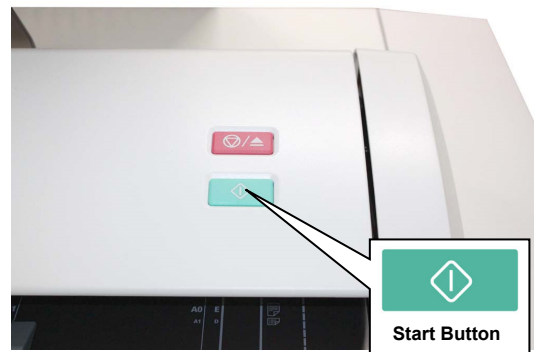

NOTE

- (1) The scanner unit does not accept originals automatically during Sleep Mode. Tap on the UI screen and then insert an original.
- (2) For the front stacking, gently lift up the prints on the print tray to avoid rubbing the print surface. A large number of prints should be removed in several sheets.
- (3) For the front stacking, the printer will inform you of "Upper Bin Full" on exceeding capacity of stacking. If the UI screen shows "Upper Bin Full", remove all the prints on the top front stacking tray.

2. 8 Stop of Scan or Copy (MFP Model)

1. If necessary, press the Scan Abort Button on the Scanner Unit to immediately stop the original while making a copy or scan.

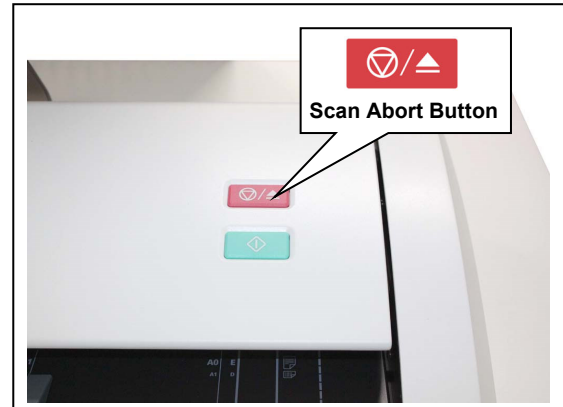

Pressing the button stops the current reading a document immediately. The current printing is stopped as well and is ejected.

! NOTE

Do not pull back or hold down the original on Original Table as an attempt to stop feeding it through Scanner Unit.

2. Lift up both sides of the Scanner Unit, and then remove a mis-fed original.



3. Gently press the Scanner Unit down and firmly close it.



Chapter 3

Error Correction

	page
3.1 Mis-feed Error	3- 2
3.1.1 Roll Deck Section Jam (Deck 1, 2, 3, 4 Mis-feed)	3- 3
3.1.2 Media Feed Section Jam (Registration Mis-feed, Feeder part Mis-feed (3))	3- 6
3.1.3 Separation Section Jam (Separation Mis-feed (1))	3-10
3.1.4 Exit Section Jam (Exit Back Mis-feed, Exit Top Mis-feed)	3-16
3.1.5 Manual Feeder Section Jam (Feeder part Mis-feed (1))	3-22
3.1.6 Scanner section Jam (Scanner document jam) (MFP Model)	3-23
3.1.7 Unexpected Interruption / Power Shutdown While in Printing	3-24
 3.2 Door Open	 3-28
3.2.1 Roll Deck (Deck 1, 2 Open)	3-28
3.2.2 Fuser Unit (Fuser Unit removing)	3-28
3.2.3 Fuser Cover (Fuser Cover Open)	3-29
3.2.4 Left Door (Left Door Open)	3-29
3.2.5 Manual Feeder (Manual Feeder Open)	3-30
3.2.6 Scanner Unit (Scanner feeder Open)	3-30
 3.3 Other Operator Call	 3-31
3.3.1 Roll Replacement	3-31
3.3.2 Toner Empty	3-31
3.3.3 Waste Cartridge full	3-32
 3.4 Service Call Error	 3-33

3.1 Mis-feed Error

"XXXX Mis-feed" is displayed in the UI screen when the media is jammed.

The jammed location when displaying "Mis-feed" is shown below.

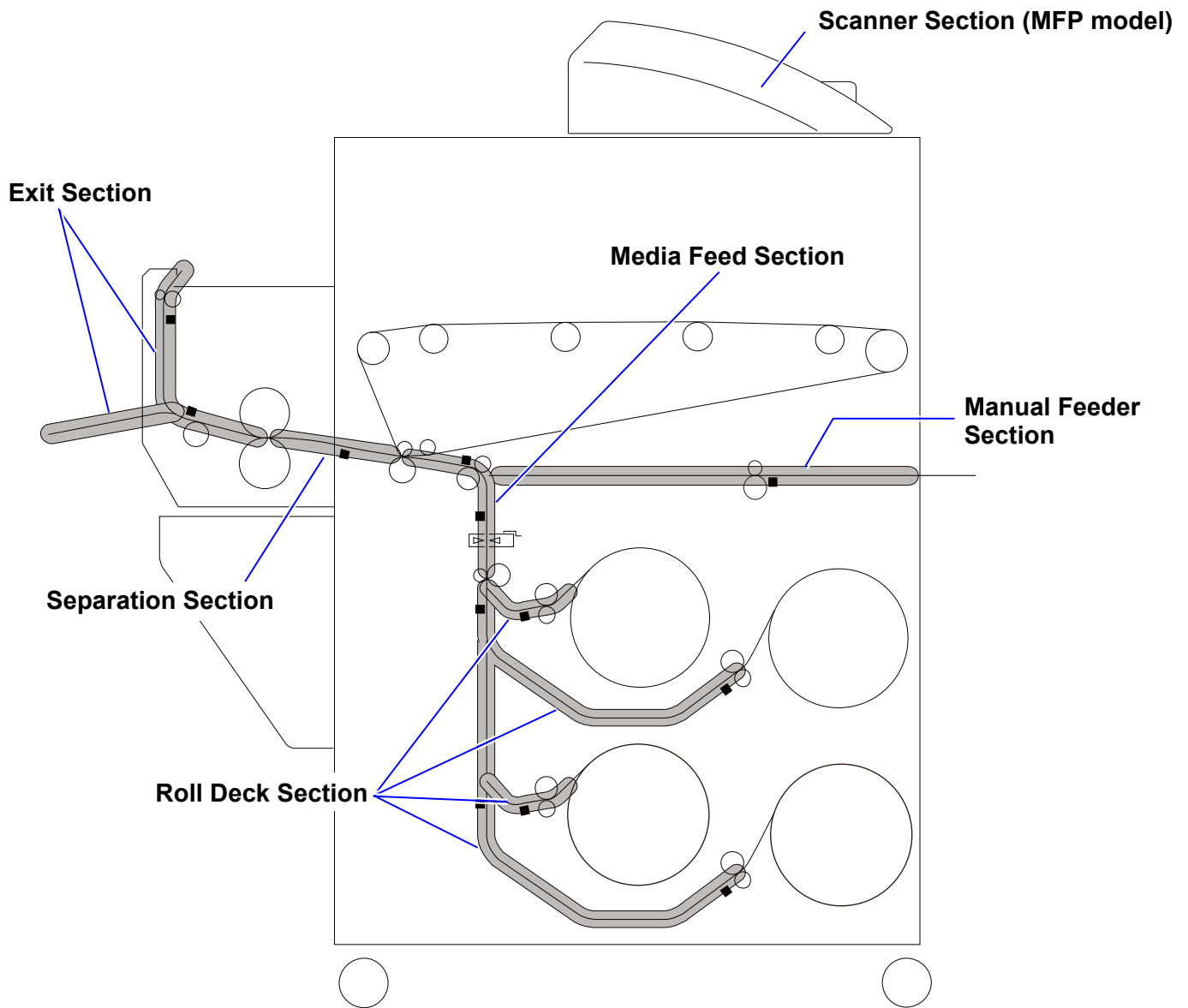

NOTE

- (1) Be careful not to get paper cuts on your hand.
- (2) Gently remove a jammed paper. When it does not reach Fuser Unit, toner on it may spill off. If toner gets into eyes or your mouth, immediately rinse them with water and contact a doctor.
- (3) Gently remove a jammed paper. When it does not reach Fuser Unit, toner on it may spill off on your cloth. Dust off your cloth. Use cold water to wash in out. Using hot water may leave a stain.
- (4) In case of a paper jam while in continuous printing, several sheets may stop in the printer at a time. Remove entire the sheets from the printer. The system will get ready after the cleaning process completes.

3. 1. 1 Roll Deck Section Jam (Deck 1, 2, 3, 4 Mis-feed)

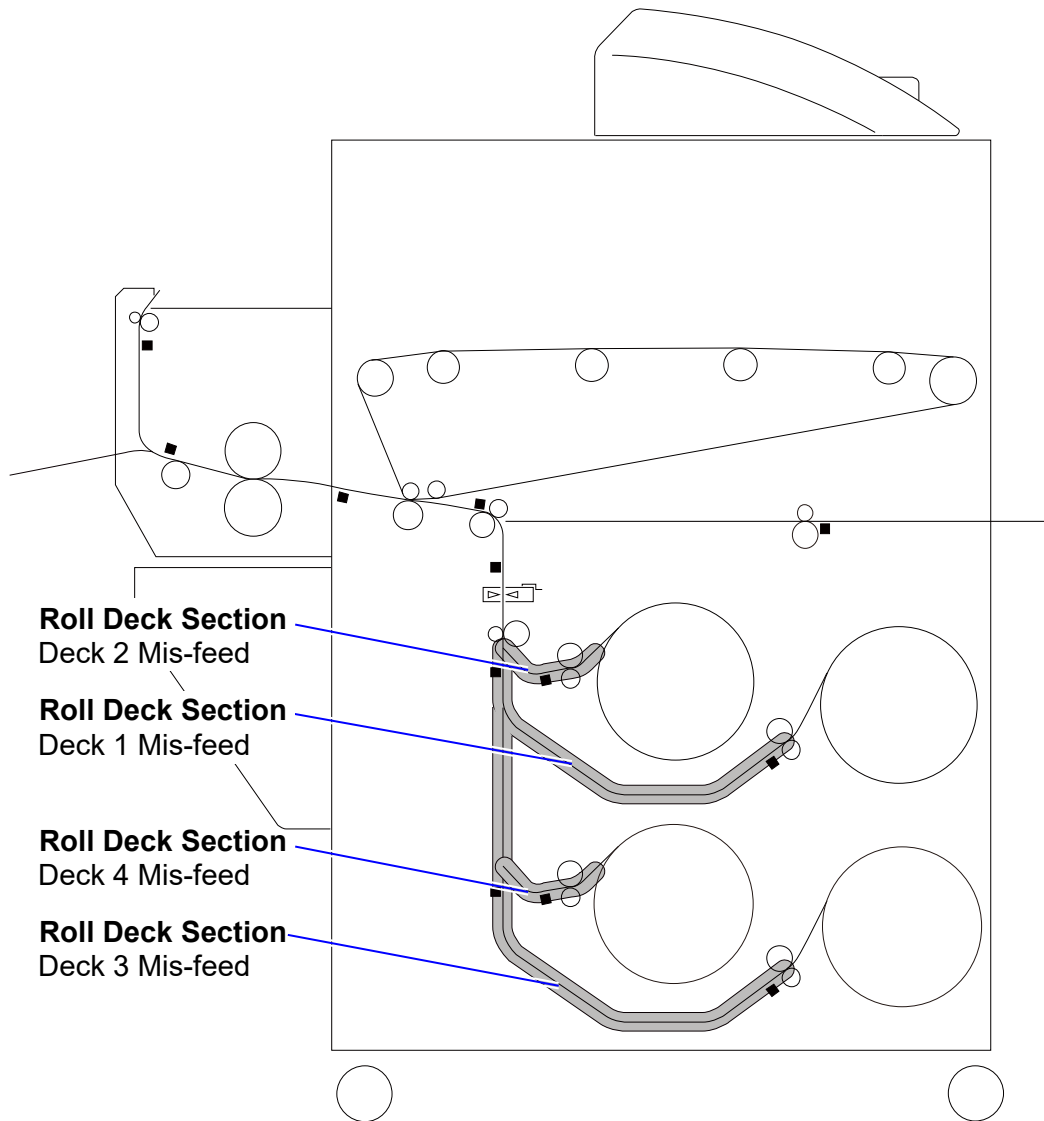

1. Open the Roll Deck in issue. And then rewind the roll onto the media core.

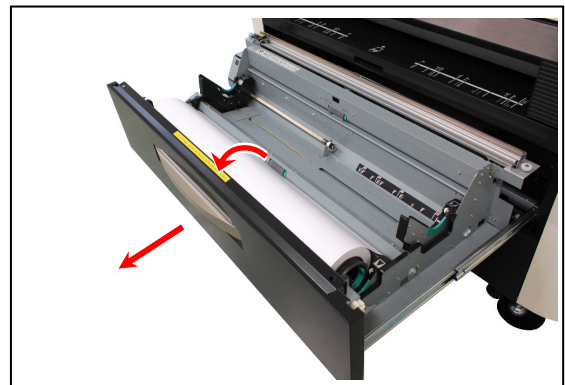

2. If the leading edge of the media is torn or folded, cut it off.

3. Set the roll media correctly.

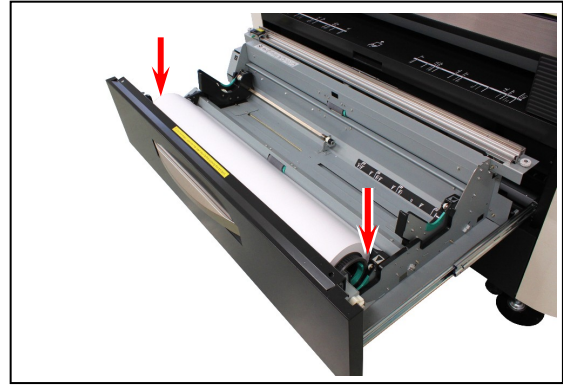

Roll 1 & 3 (front)

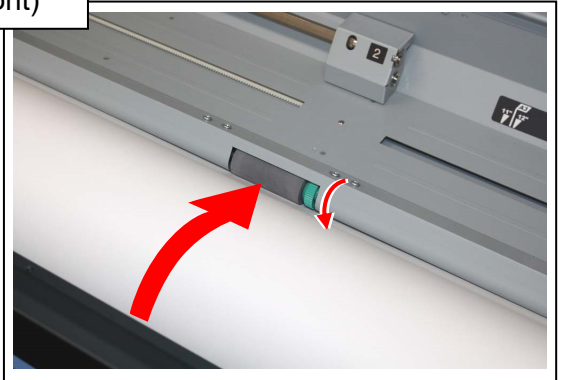

Roll 2 & 4 (rear)

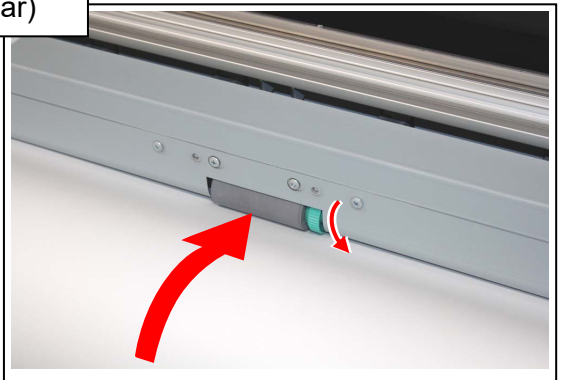

! NOTE

The outside rim of Flange should meet the black triangle marked on Slide Guide. Otherwise the roll media may fall in Roll Deck or result in an incorrect media feeding.

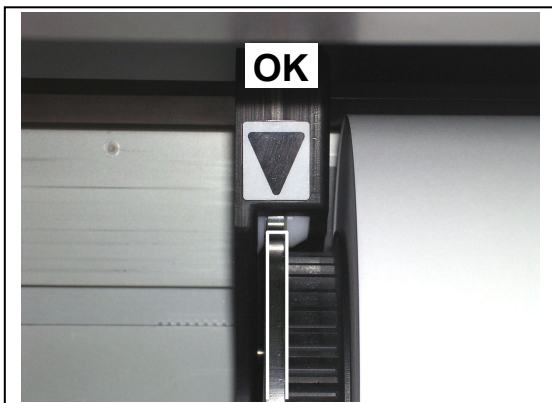

Correct

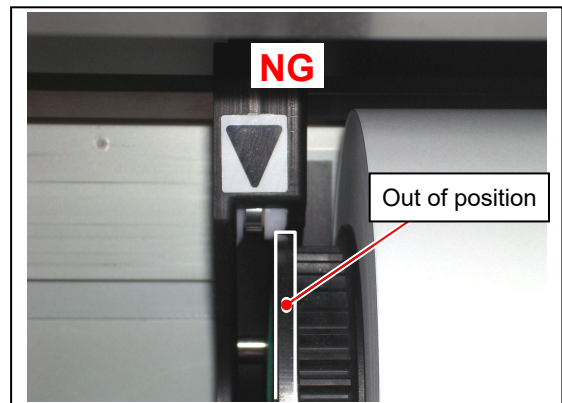

Wrong

4. Close the Roll Deck.

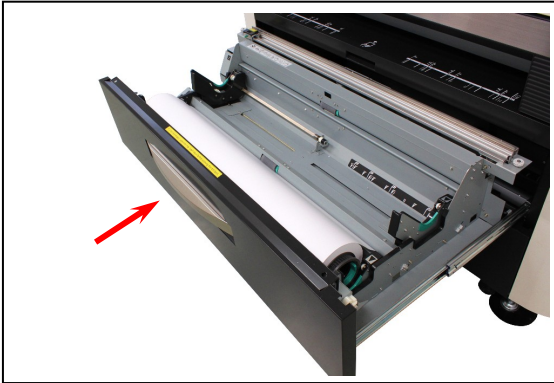

3. 1. 2 Media Feed Section Jam (Registration Mis-feed, Feeder part Mis-feed (3))

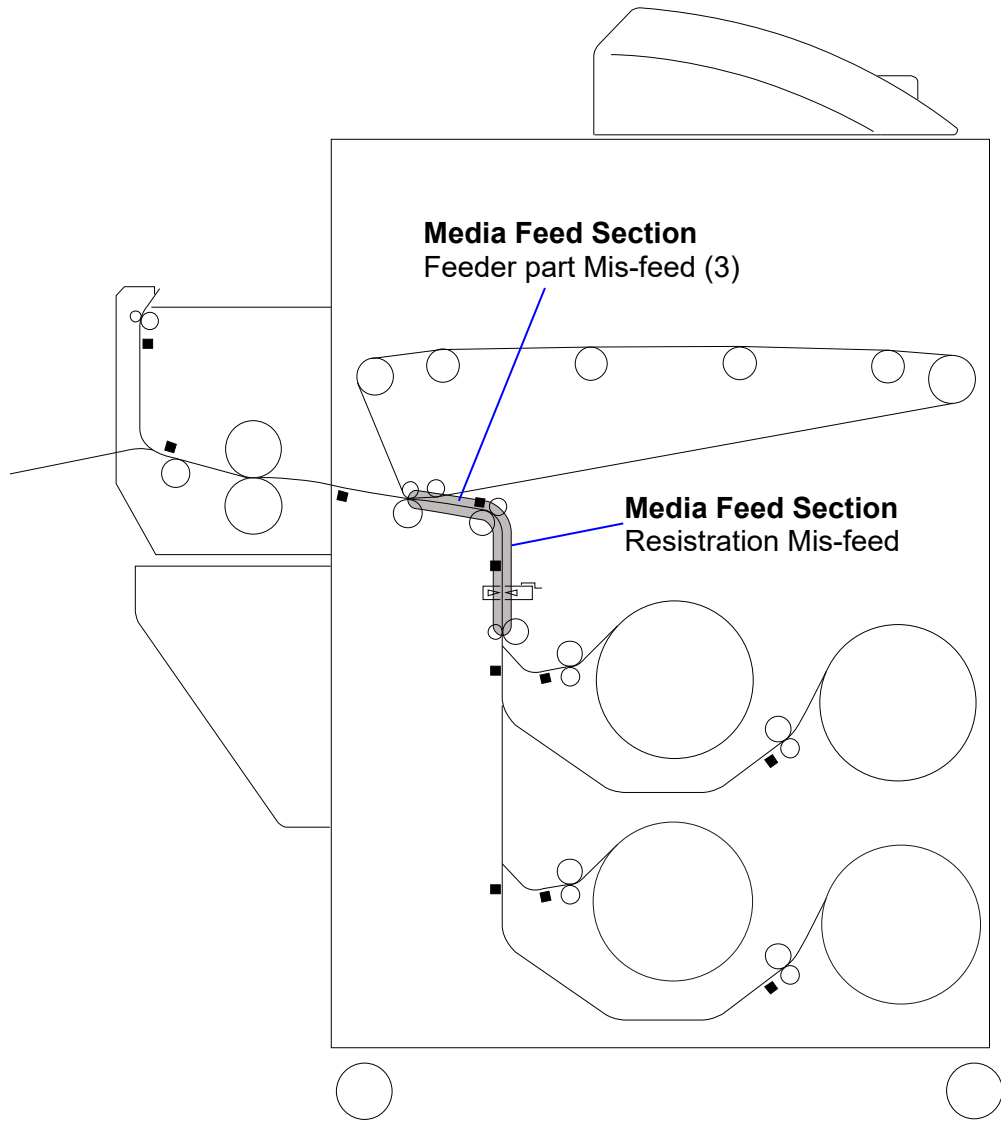

1. Release the Fuser Release Lever (1) to the arrow direction, and then slide the Fuser Unit backward.
With paying great attention not to touch the Fuser Unit, remove jammed sheet from between the printer and the Fuser Unit. If you cannot pinch and remove the sheet, go to the next step.

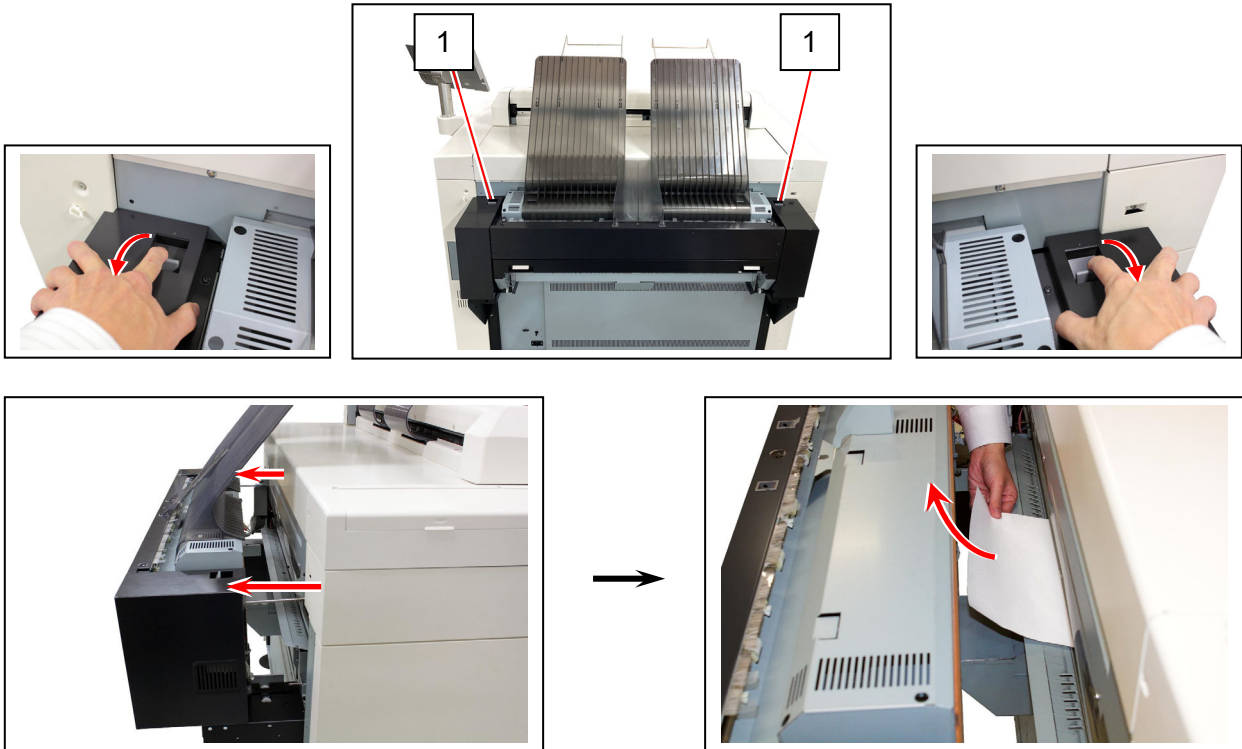

If you remove this sheet from the printer, please go to the next step to confirm if there is another sheet in the media path.

! WARNING

There are extremely hot parts the Fuser Unit. Do not touch any parts in the Fuser Unit, or you will be burnt.

2. Hold the handle (2) and pull the Feeder Unit (Manual Feeder) (3).



3. Open the Left Door (4).



4. Take out a jammed sheet from the opening.

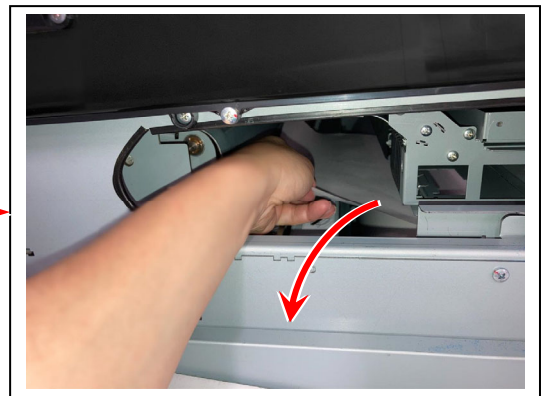

5. Close the Left Door (4).

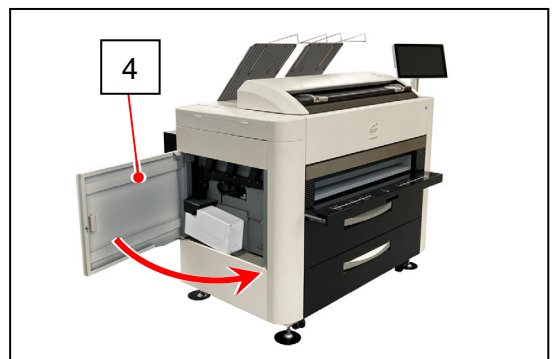

6. Close the Feeder Unit (Manual Feeder) (3).



7. Press the Fuser Unit to the printer side in place until the Fuser Release Lever clicks.
If the Fuser Unit is not set firmly, "Fuser Unit Open" pops up in the UI screen.

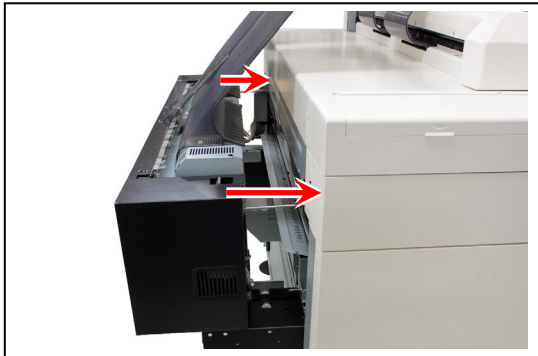

3. 1. 3 Separation Section Jam (Separation Mis-feed (1))

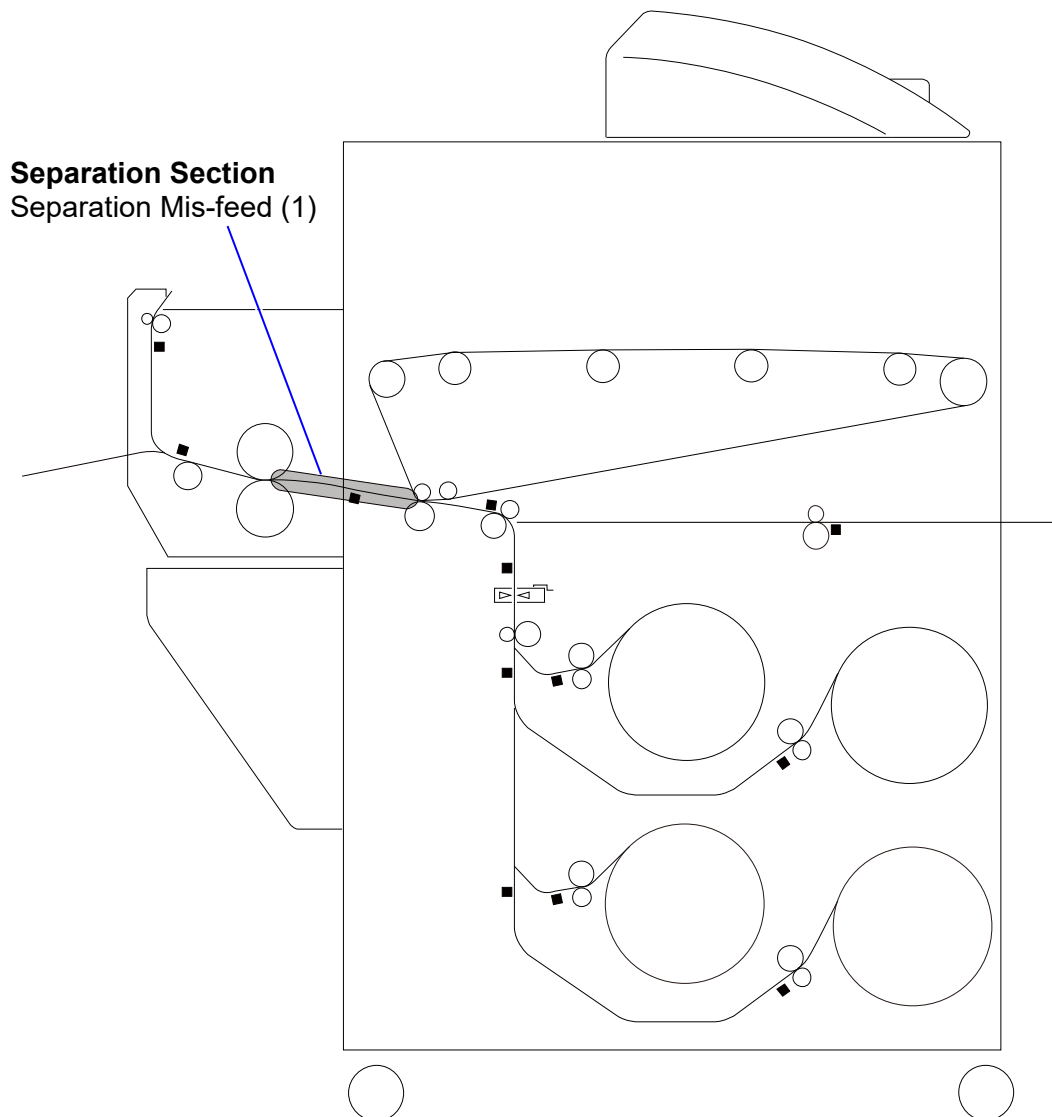

1. Open the Fuser Cover (1).

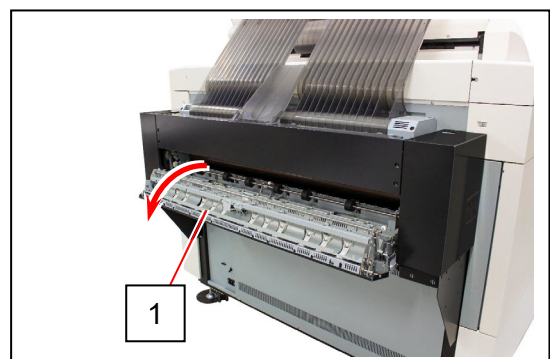

2. Pinch and gently pull jammed sheet toward you.



⚠ WARNING

- (1) There are extremely hot parts inside the Fuser Unit. Do not touch any parts in the Fuser Unit, or you will be burnt.
Also the mis-fed media can be very hot. Be careful not to get burnt when you remove it.
- (2) The stripping claws (2) with a sharp edge are on the inside face of the Fuser Cover. Take care not to get scratched on them when removing a sheet.

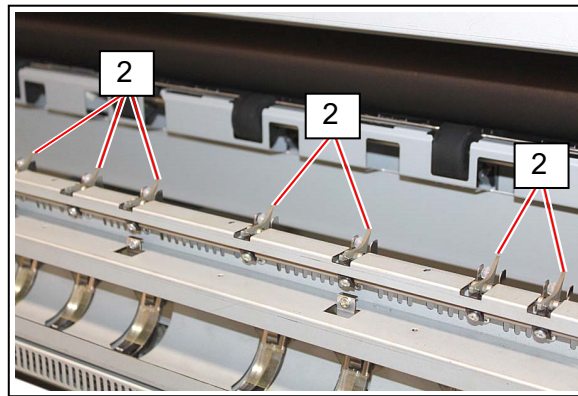

3. Release the Fuser Release Lever (3) to the arrow direction, and then slide the Fuser Unit backward.
With paying great attention not to touch the Fuser Unit, remove a jammed sheet from between the printer and the Fuser Unit.

NOTE

In the following cases, open the Feeder Unit (Manual Feeder) as well.

- If the Fuser Unit cannot be released from the printer.
- If the jammed sheet gets stuck and you cannot pull it.

Hold the handle (4) and pull the Feeder Unit (Manual Feeder) (5).

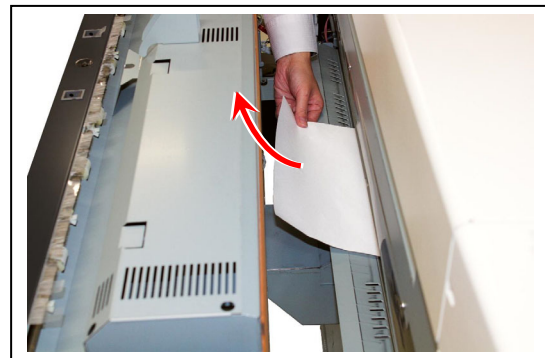
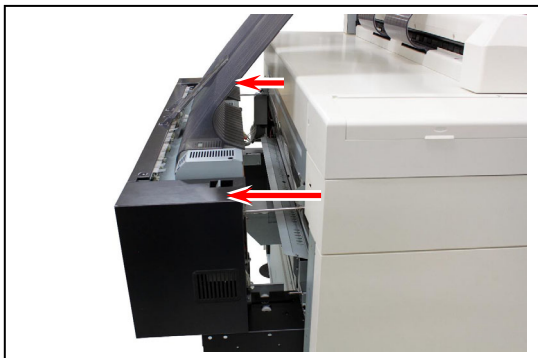
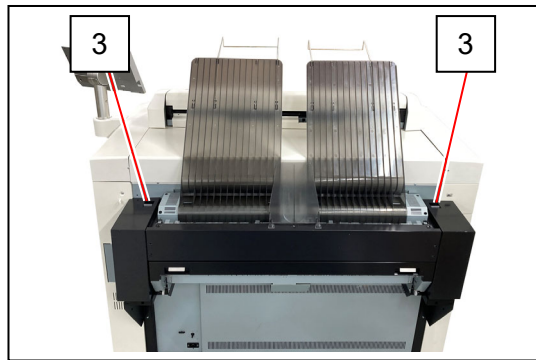

If you remove this sheet from the printer, please go to the next step to confirm if there is another sheet in the media path.

WARNING

There are extremely hot parts the Fuser Unit. Do not touch any parts in the Fuser Unit, or you will be burnt.

(See also next page)

Reference

If it is not easy to remove the jammed sheet from either right or left side, please stand in the rear side and use both hands to pull the sheet.

For easier access from the rear, remove the Exit Tray 2 (6) and the Exit Tray (7). After removing jammed sheet, return the Exit Tray (7) and the Exit Tray 2 (6) in place.

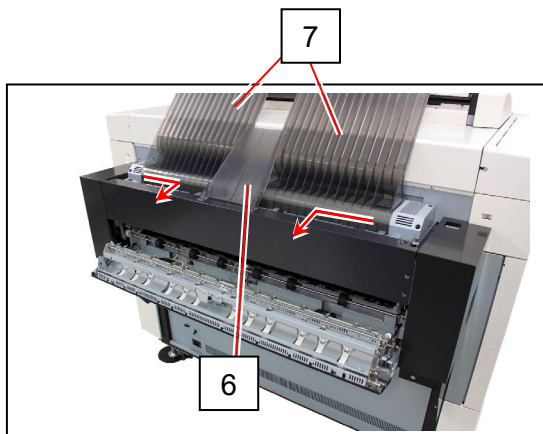

4. Hold the handle (4) and pull the Feeder Unit (Manual Feeder) (5).



5. Open the Left Door (8).



6. Take out a jammed sheet from the opening.



7. Close the Left Door (8).

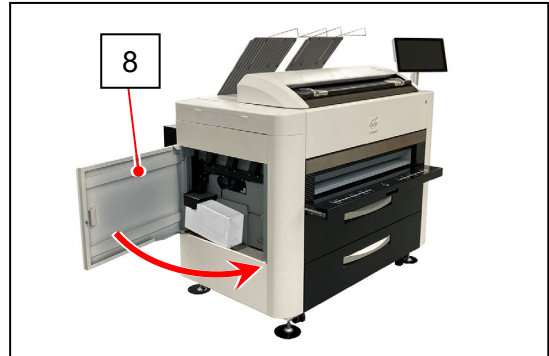

8. Close the Feeder Unit (Manual Feeder) (5).



9. Press the Fuser Unit to the printer side in place until the Fuser Release Lever clicks. If the Fuser Unit is not set firmly, "Fuser Unit Open" pops up in the UI screen.

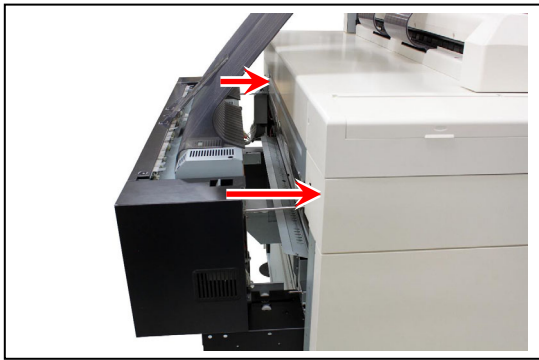

10. Close the Fuser Cover (1).

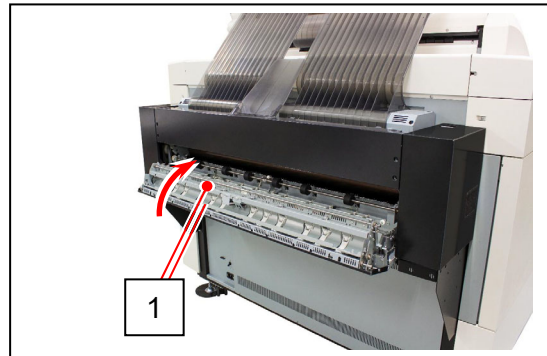

3. 1. 4 Exit Section Jam (Exit Back Mis-feed, Exit Top Mis-feed)

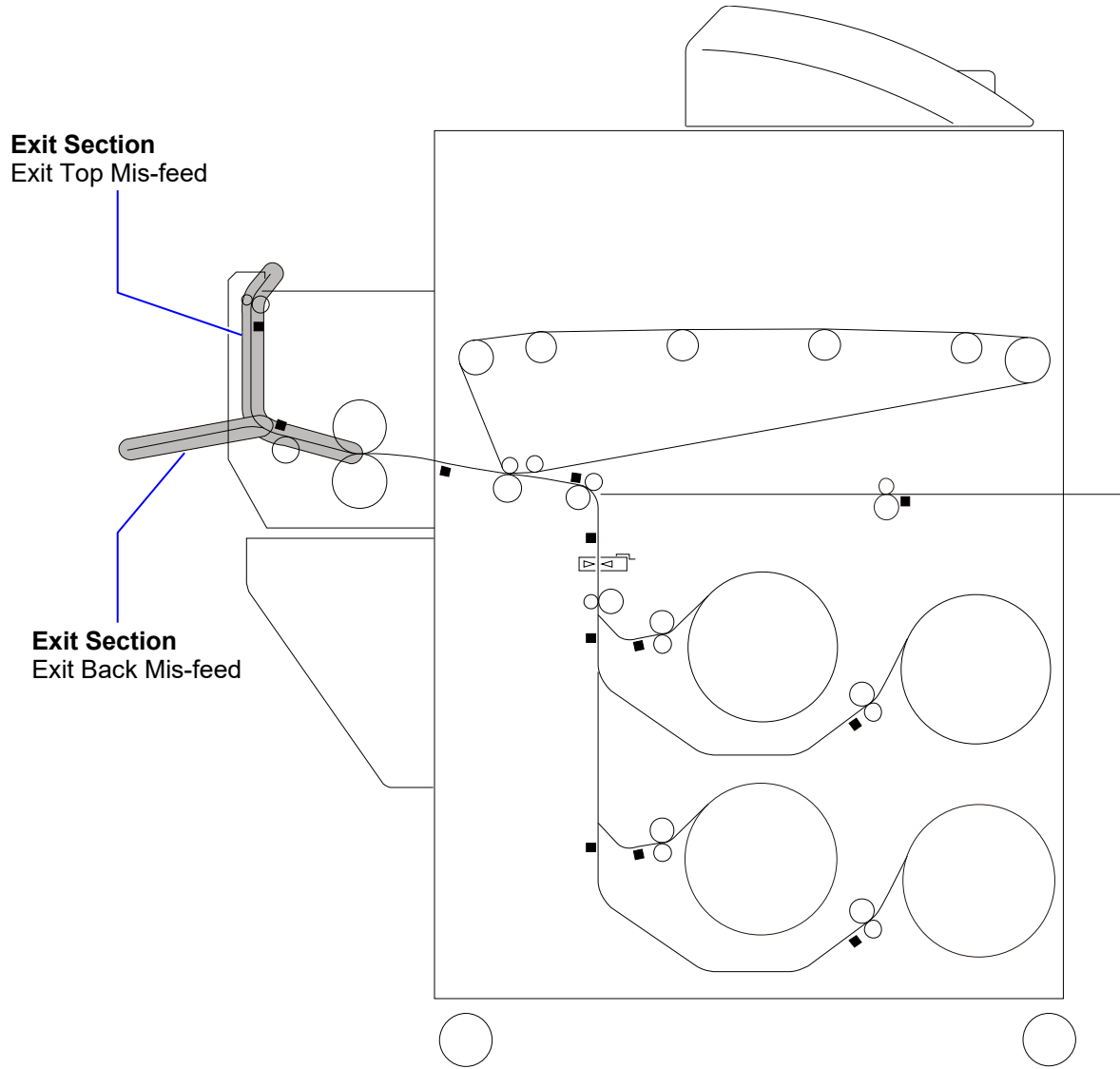

1. When jammed sheet is in the Exit Section, gently pull it out.

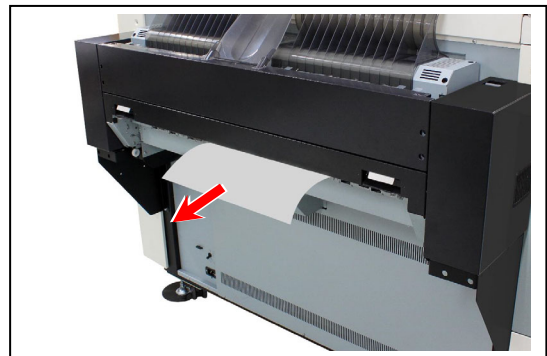

2. Open the Fuser Cover (1).

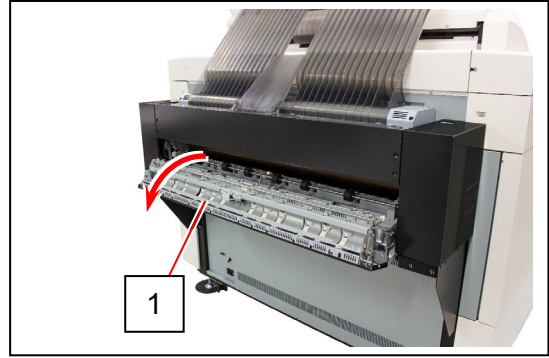

3. Pinch and gently pull jammed sheet toward you.

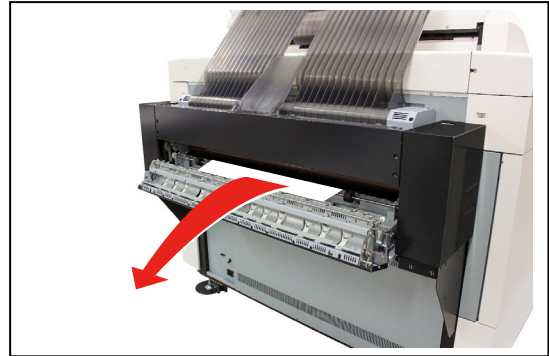

! WARNING

(1) There are extremely hot parts inside the Fuser Unit. Do not touch any parts in the Fuser Unit, or you will be burnt.
Also the mis-fed media can be very hot. Be careful not to get burnt when you remove it.

(2) The stripping claws (2) with a sharp edge are on the inside face of the Fuser Cover. Take care not to get scratched on them when removing a sheet.

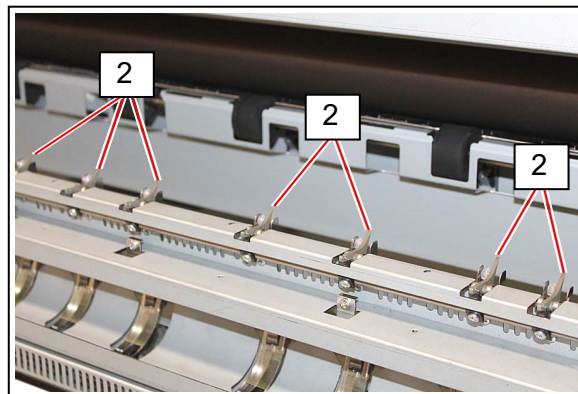

4. Release the Fuser Release Lever (3) to the arrow direction, and then slide the Fuser Unit backward.
With paying great attention not to touch the Fuser Unit, remove jammed sheet from between the printer and the Fuser Unit.

NOTE

In the following cases, open the Feeder Unit (Manual Feeder) as well.

- If the Fuser Unit cannot be released from the printer.
- If the jammed sheet gets stuck and you cannot pull it.

Hold the handle (4) and pull the Feeder Unit (Manual Feeder) (5).

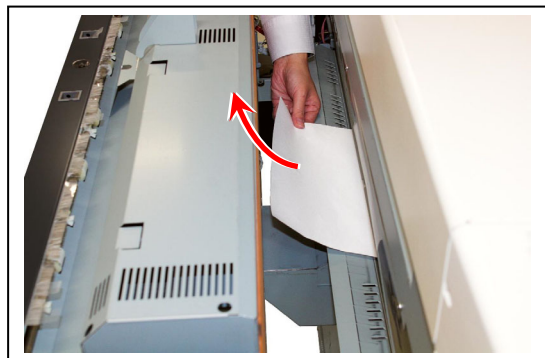
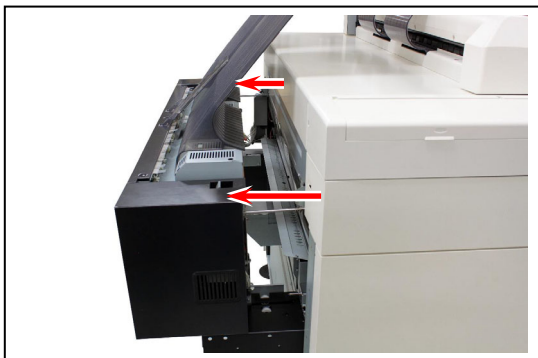
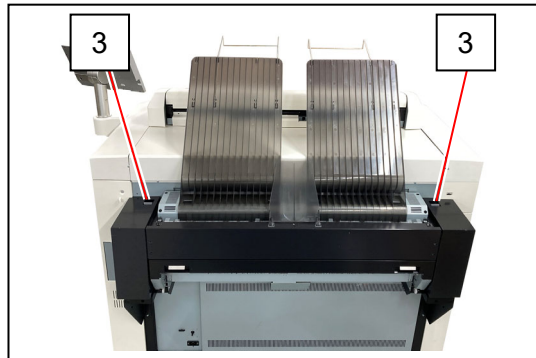
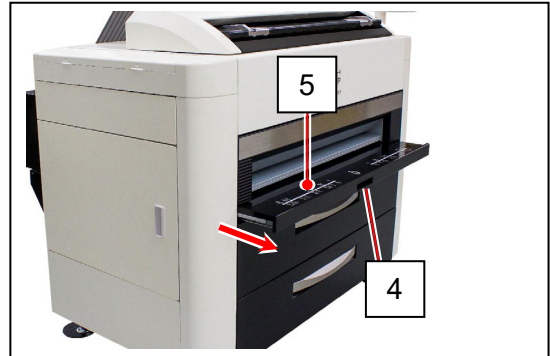

If you remove this sheet from the printer, please go to the next step to confirm if there is another sheet in the media path.

WARNING

There are extremely hot parts the Fuser Unit. Do not touch any parts in the Fuser Unit, or you will be burnt.

(See also next page)

Reference

If it is not easy to remove the jammed sheet from either right or left side, please stand in the rear side and use both hands to pull the sheet.

For easier access from the rear, remove the Exit Tray 2 (6) and the Exit Tray (7). After removing jammed sheet, return the Exit Tray (7) and the Exit Tray 2 (6) in place.

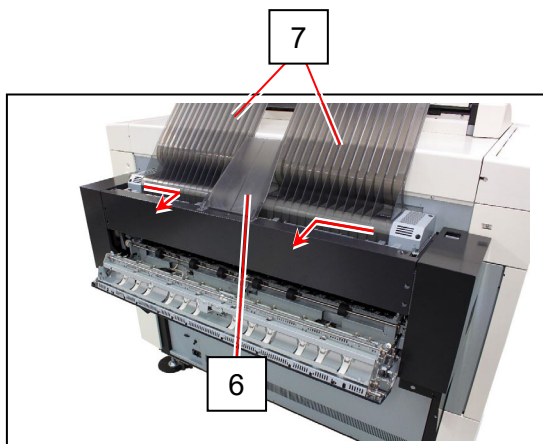

5. Hold the handle (4) and pull the Feeder Unit (Manual Feeder) (5).



6. Open the Left Door (8).

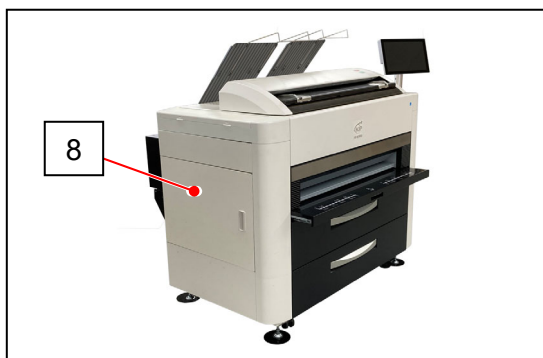

7. Take out a jammed sheet from the opening.



8. Close the Left Door (8).

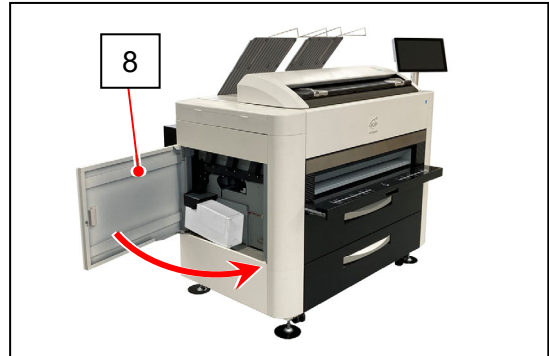

9. Close the Feeder Unit (Manual Feeder) (5).



10. Press the Fuser Unit to the printer side in place until the Fuser Release Lever clicks.
If the Fuser Unit is not set firmly, "Fuser Unit Open" pops up in the UI screen.

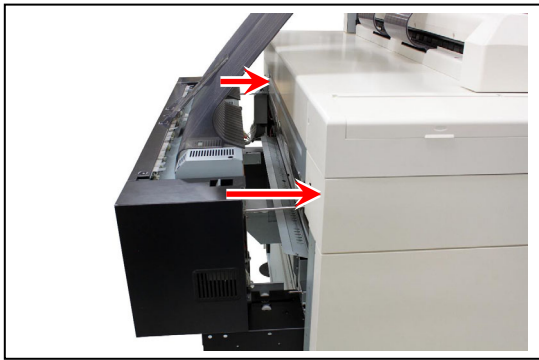

11. Close the Fuser Cover (1).

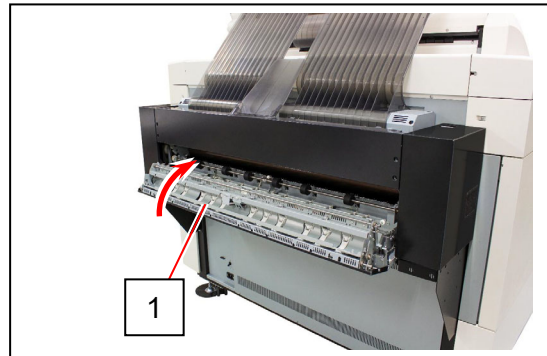

3. 1. 5 Manual Feeder Section Jam (Feeder part Mis-feed (1))

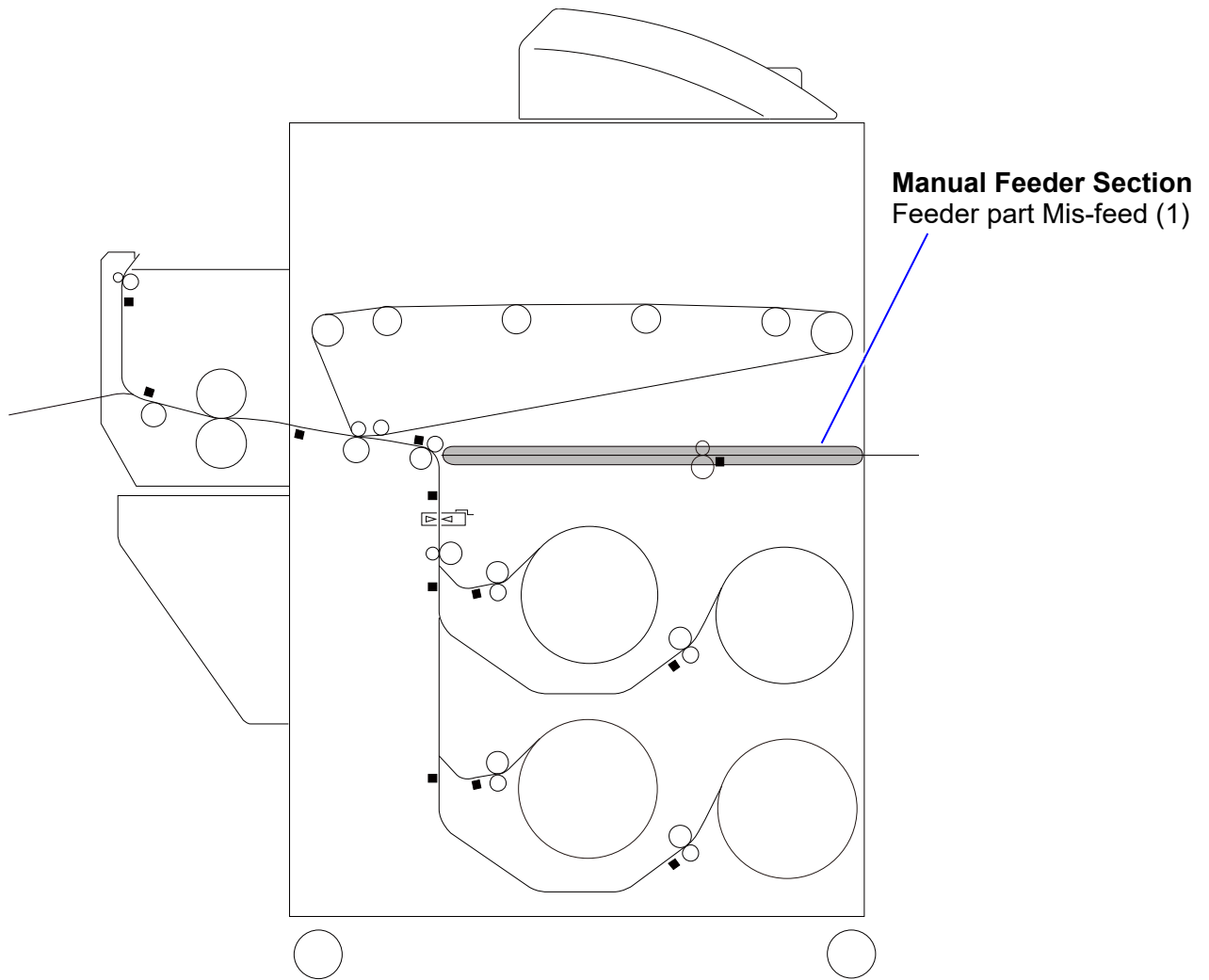

1. Hold the knob (1) and pull out the Bypass Feeder (2).
Pull out the mis-feed cut sheet.



! NOTE

The mis-feed cut sheet should be replaced with a new one if its leading edge has a torn or fold. Or it should be used upside down to keep the damaged edge from been inserted. An extremely creased cut sheet may cause mis-feed again.

3. 1. 6 Scanner Section Jam (Scanner document jam) (MFP Model)

If an original is mis-fed while scanning, the UI screen shows “Scanner document jam”. Follow the instruction below to remove the mis-fed original.

1. Lift up both sides (1) of the Scanner Unit

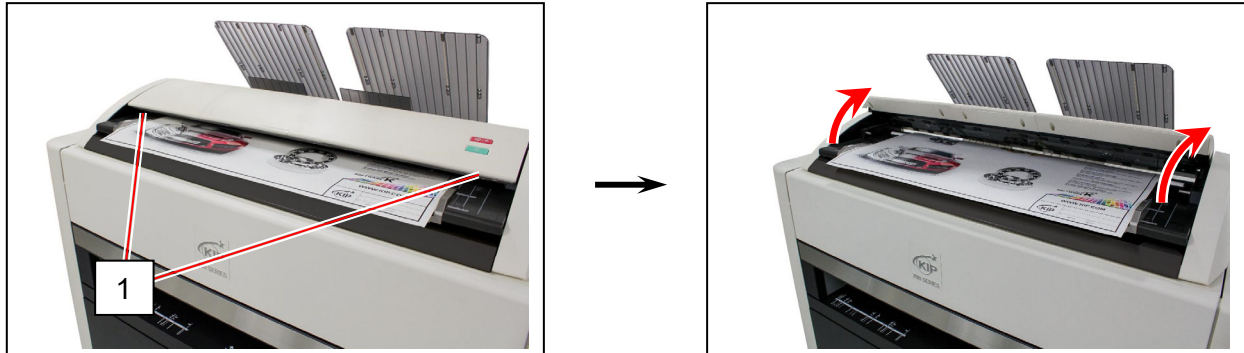

2. Remove a mis-feed original.

3. Gently press the Scanner Unit down and firmly close it.



! NOTE

Press down the Scanner Unit on both sides to close it.
Do not close it by pressing only one side down.

3. 1. 7 Unexpected Interruption / Power Shutdown While in Printing

Normally, the printer cuts the media being used and then will stop in case of a media mis-feed.

For the following unexpected “while in printing” situations, the printer does NOT cut the media and immediately stops.

- Roll Deck / Fuser Cover / Left Door is opened.
- The printer is turned off.
- The power cord is unplugged.
- Blackout.

In these cases, please follow the instruction below to remove / rewind the remained media in the path.

NOTE

Please do not open the Roll Deck unless instructed to do so.
Doing so could cause damage on the Cutter Unit in the Roll Deck.

1. Open the Fuser Cover (1).

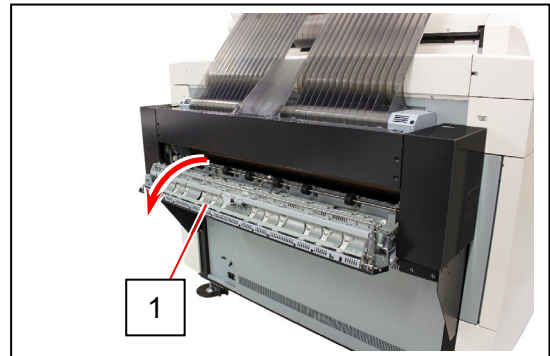

2. Hold the handle (4) and pull the Feeder Unit (Manual Feeder) (5).



3. Open the Roll Deck (4).
(4-roll model) Open the Upper Roll Deck.

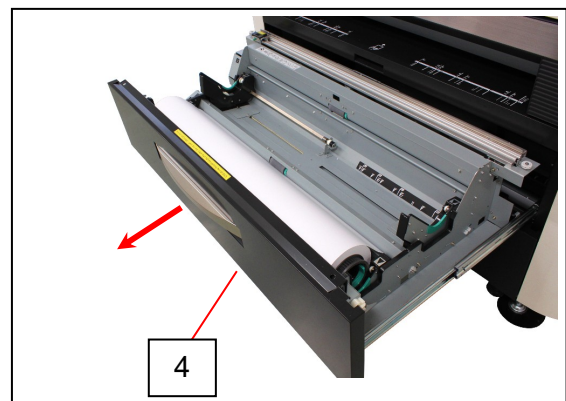

4. Pinch and slide the green Tab (8) from one end to the other end at a time. The leading edge section that is coming out from the slit is cut off, and this straightens the leading edge of the roll media.

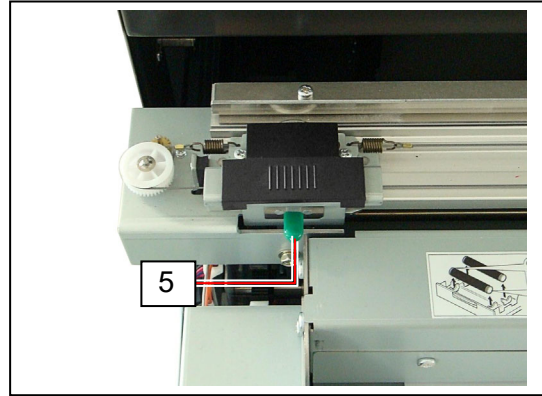

! NOTE

Please ensure to follow the instruction below when sliding the green Tab. Incorrect operation will lead you to the damage to the Cutter Unit.

- (1) When you slide the green Tab to cut the media, please do not pull it to the front (toward you) because it will cause to damage the cutter unit.
- (2) Please hold only the green Tab when sliding the cutter. Do not hold any other part as it can cause to damage the Cutter Unit.

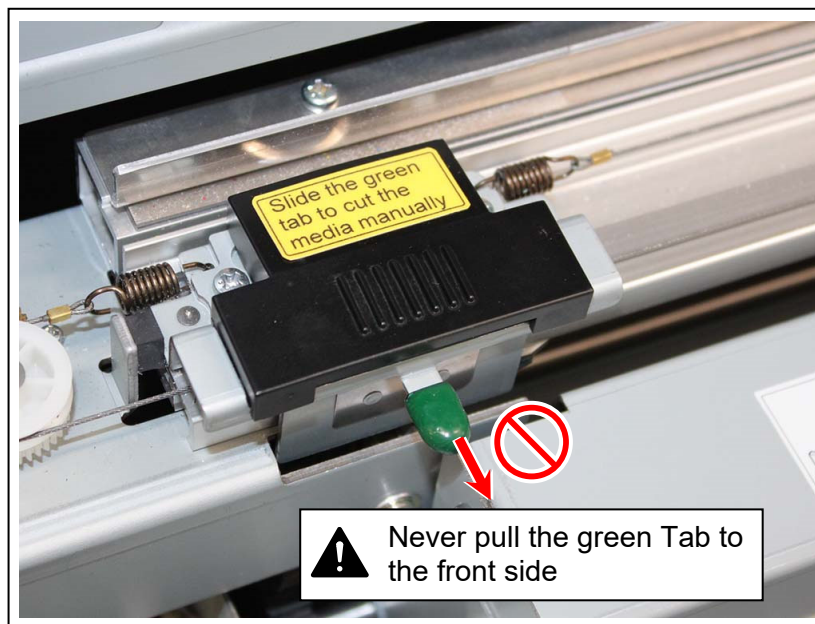

- (3) Do not touch the cutter Blade under the black plastic cover.

5. Rewind the roll media which had cut on the step 4.
(4-roll model) When you rewind the roll in the lower Roll Deck drawer, first close the Upper Roll Deck, and then open the Lower Roll Deck.

6. Push the Roll Deck (4) back in.

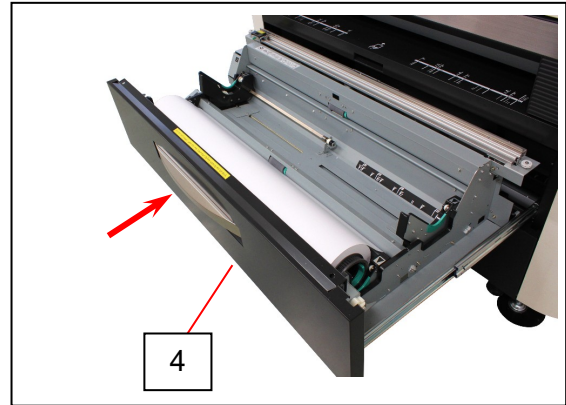

! NOTE

- (1) Surely close the Roll Deck until it is locked. A paper jam may occur if not locked perfectly.
- (2) Be careful not to catch your finger in between Roll Deck drawers.

7. Pinch and gently pull sheet (if there is) toward you.

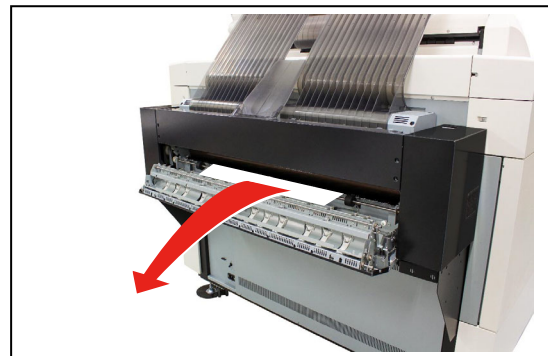

! WARNING

- (1) There are extremely hot parts inside the Fuser Unit. Do not touch any parts in the Fuser Unit, or you will be burnt.
Also the mis-fed media can be very hot. Be careful not to get burnt when you remove it.
- (2) The stripping claws (6) with a sharp edge are on the inside face of the Fuser Cover. Take care not to get scratched on them when removing a sheet.

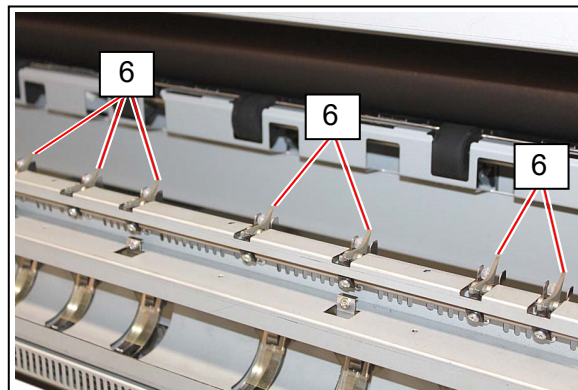

8. Close the Feeder Unit (Manual Feeder) (3).



9. Close the Fuser Cover (1).

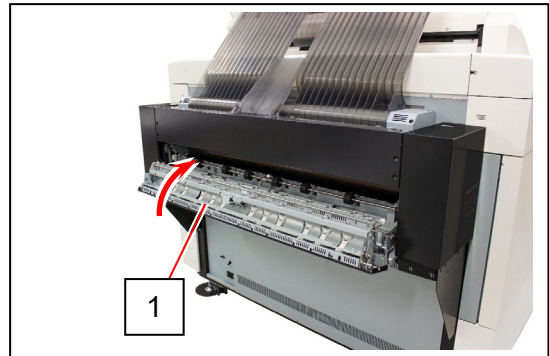

10. Confirm if the Power Cord Socket is surely plugged to the wall inlet. Turn on the printer.

11. In the KIP Touch GUI - Home screen, tap the "MEDIA" area.

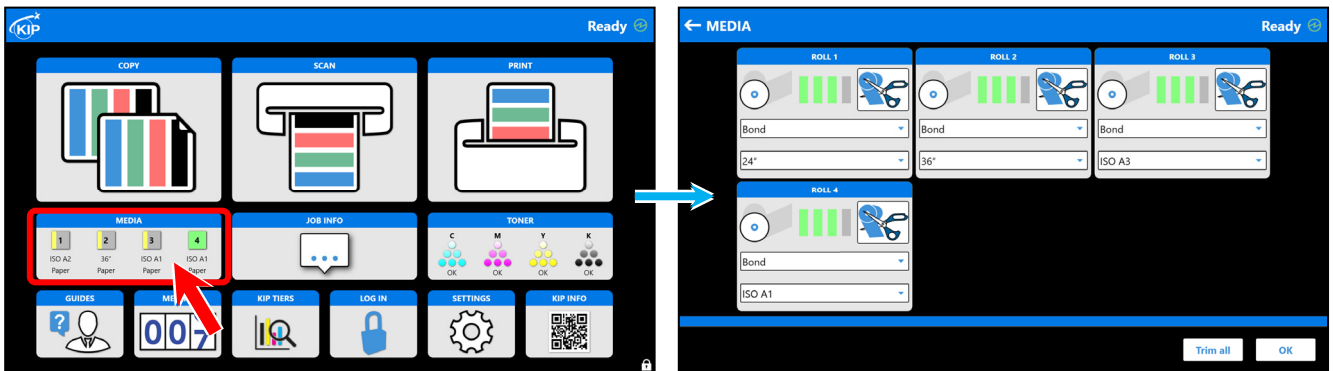

12. Start "Trim Cut" to the re-wound roll media on the step 5.

3. 2 Door Open

"Door Open" is displayed in the UI screen when the door in each unit is opened.

3. 2. 1 Roll Deck (Deck 1 Open, Deck 2 Open)

Close the Roll Deck securely to clear "Deck Open".



3. 2. 2 Fuser Unit (Fuser Unit Open)

Close the Fuser Unit securely to clear "Fuser Unit removing".

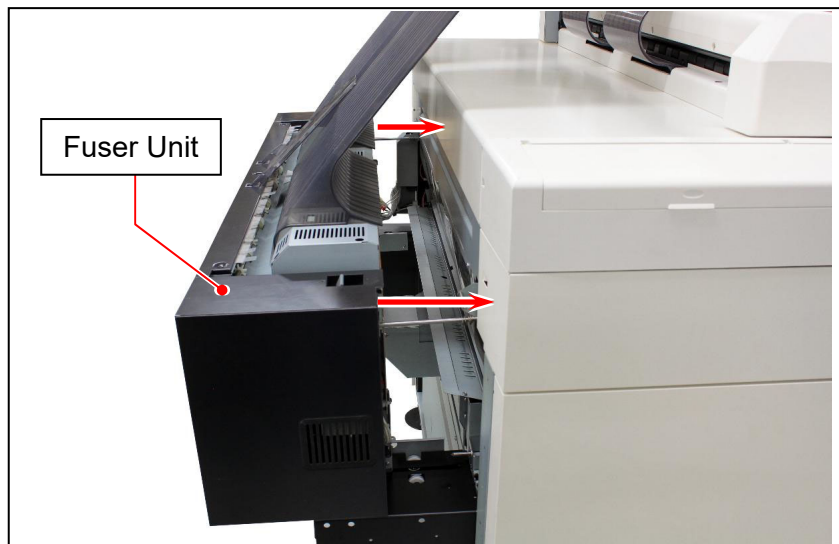

3. 2. 3 Fuser Cover (Fuser Cover Open)

Close the Fuser Cover securely to clear "Fuser Cover Open".

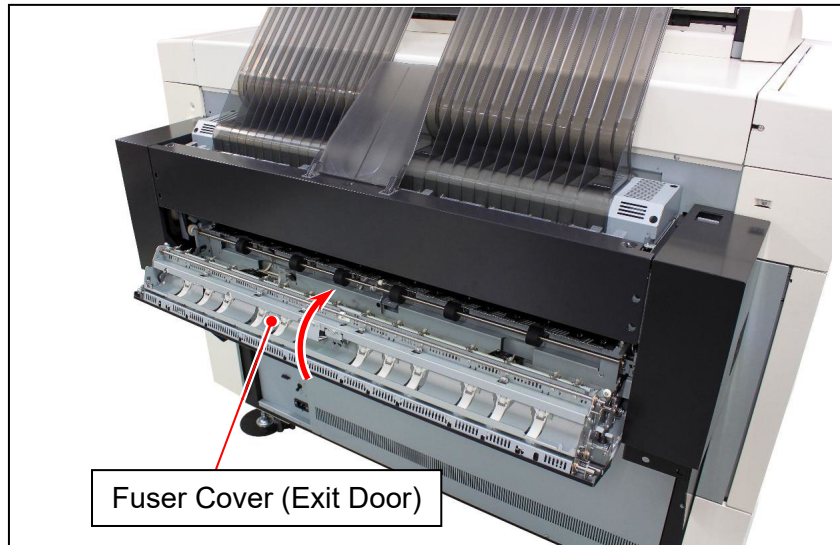

3. 2. 4 Left Door (Left Door Open)

Close the Left Door securely to clear "Left Door Open".

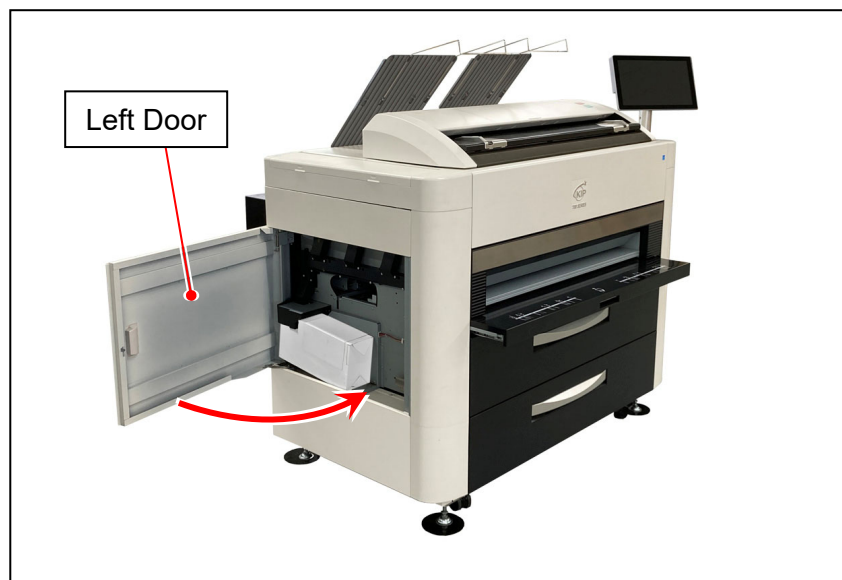

3. 2. 5 Feeder Unit / Manual Feeder (Manual Feeder Open)

Close the Feeder Unit (Manual Feeder) securely to clear "Manual Feeder Open".



3. 2. 6 Scanner (Scanner Feeder Open)

The UI screen shows "Scanner Feeder Open" if the Scanner Unit is open. (not closed properly)
Close the Scanner Unit securely to clear "Scanner Feeder open".

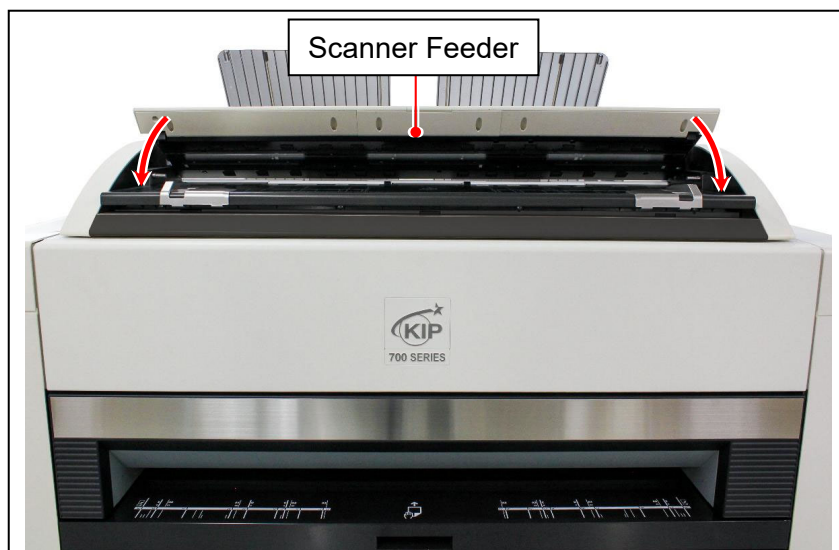

3.3 Other Operator Call

3.3.1 Out of Media

When the printer is running out of a loaded roll media, the UI Screen will display “Out of Media” sign.

If there is no suitable roll media required for the print job being processed, the UI Screen will prompt “Out of Media” sign as well. Please load the required roll media to any Roll Deck.

For the roll replacement procedure, see [2.3 Replacing the Roll Media].



3.3.2 Toner Empty

When the printer is running out of toner, the UI Screen will display “Toner Empty” sign.

For the toner supply procedure, see [2.5 Toner Supply].



3. 3. 3 Waste Cartridge Full

When the Toner Receptacle is full, the UI screen shows “Waste Cartridge Full.”
The printer does not restart operation until the Toner Receptacle is properly replaced.
For replacement procedure, see [2.6 Replacing Toner Receptacle].

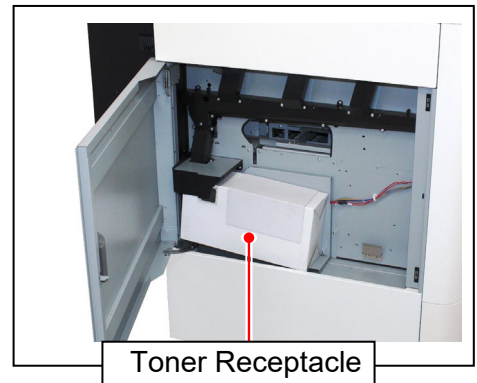
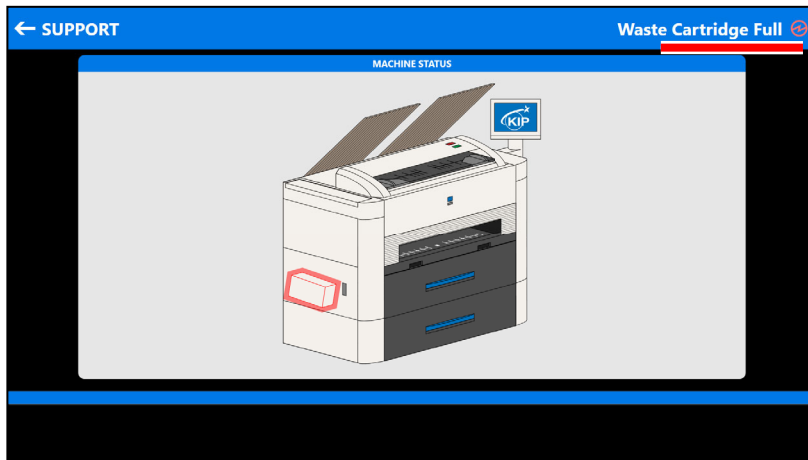

3.4 Service Call Error

If an error with significant effect on the printer occurs, the printer stops the operation and indicates the related Service Call Error (Customer Engineer Call Error) in the UI screen. Call your service staff immediately as these problems can be fixed by a well trained technician only.

Before calling the service staff, cycle the power of the printer. If the error is indicated again, turn off the printer, unplug the power cord, and then call the service staff with reporting the error code “E-xxxx”.

- Sensor Error
- Motor Error
- Cutter Error
- Fan Error
- Fusing Temperature Error
- LED Head Error
- High Voltage Power Supply Error
- Density Control Error
- Belt Skew Error
- Out of Web (Web is an embedded cleaner for the Fuser Unit)

A corresponding code/description for the error will be displayed in the top column (status region) in the UI screen.

(E-0101 shown as example)

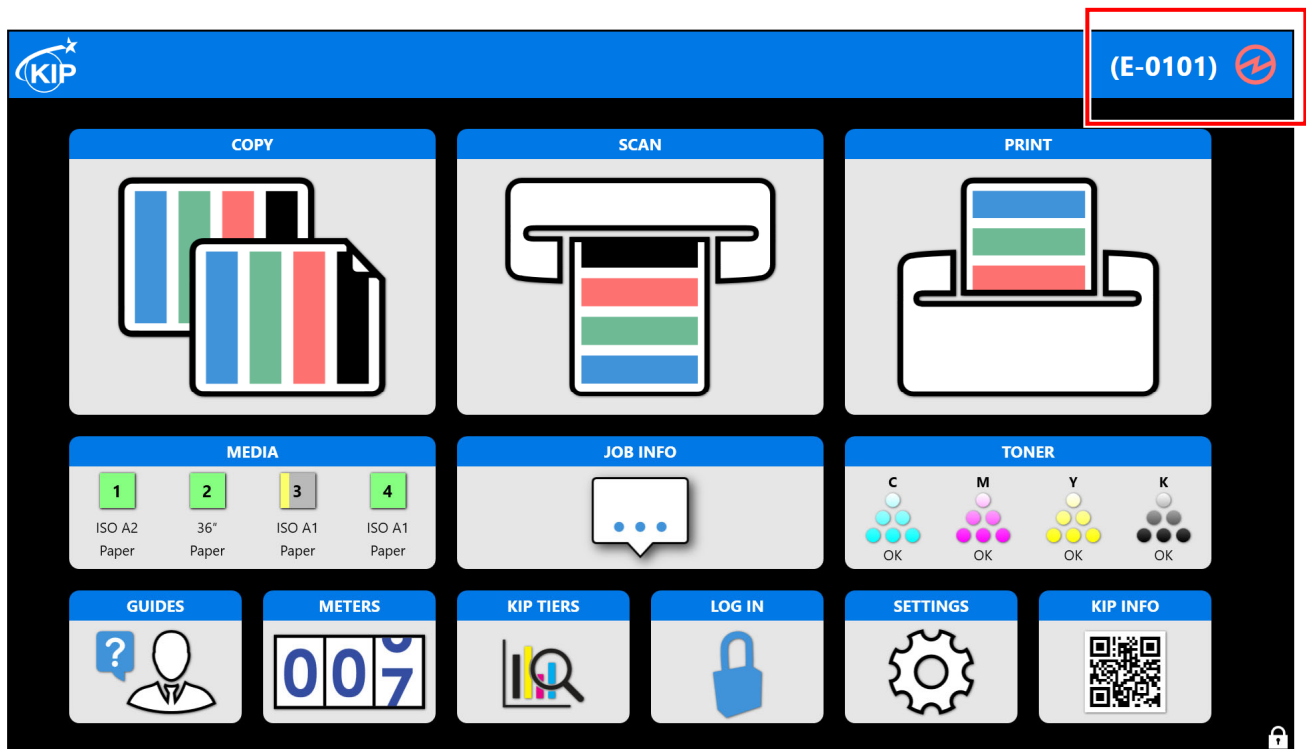

Chapter 4

Maintenance

4.1	Paper Exit section	page 4- 2
4.1.1	Exit Rollers	4- 2
4.2	Scanner Unit (MFP Model)	4- 5
4.2.1	Scan Glass, Feed Roller, Guide Plate	4- 5
4.2.2	Sensor	4- 8
4.3	Touch Screen	4-10

Before cleaning the printer, turn off the printer, wait two minutes for shutdown, and then disconnect the power cord from the wall outlet.

Wipe down the exterior surface with a soft, dry, clean cloth. To prevent the surface of your exterior cover from changing color, do not spray with or apply alcohol or the other volatile substances.

4. 1 Paper Exit section

4. 1. 1 Exit Rollers

The dirt on the Exit Rollers may be adhered to the cutting face of the trailing part on the print. For this case, please clean 6 Exit Rollers (1) on the Paper Exit section with the cloth which is wrung out the water.

For the prevention, cleaning these Exit Rollers once a week is recommended. When producing many prints, check the state of the Exit Rollers (1) and suitably clean them.

The half circumference of the exposed Exit Roller can be cleaned by one cleaning work. The entire circumference of the Exit Rollers can be evenly cleaned by the weekly cleaning.

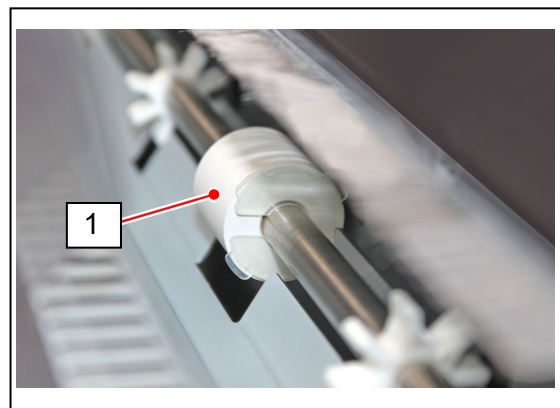
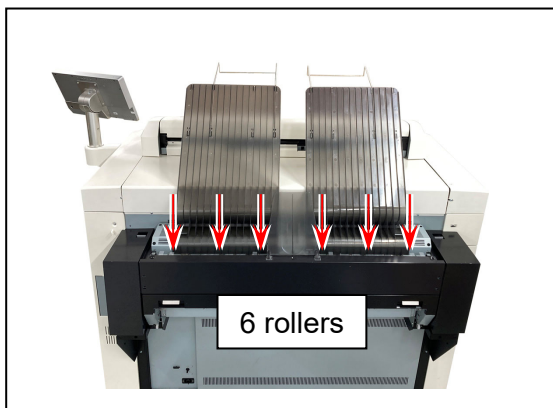

1. Read the NOTE column on the next page, and then remove the Exit Tray 2 (2) and the Exit Tray (3).

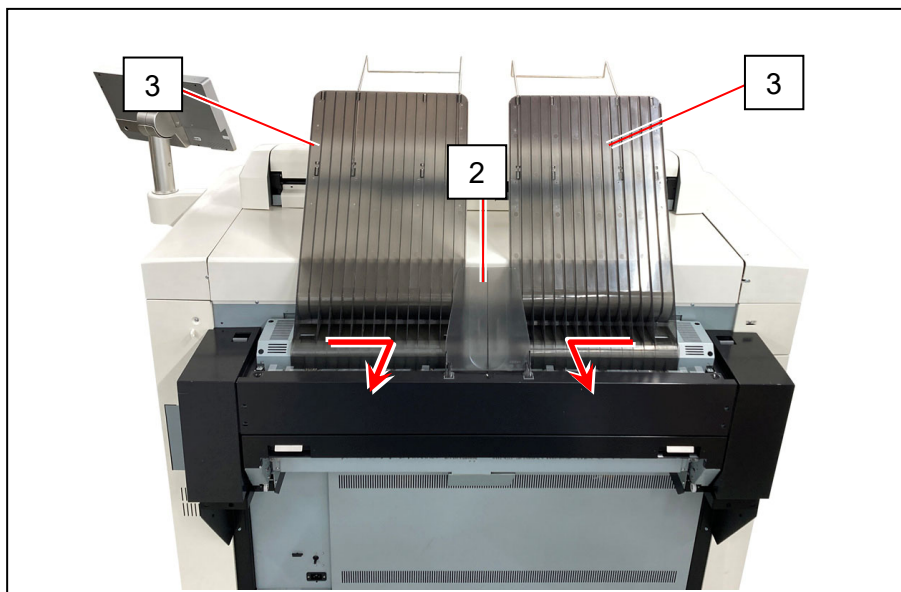

! NOTE

Carefully remove the Exit Tray (3) so as not to touch the clear plastic sheets (4) and the Discharging Brush (5).

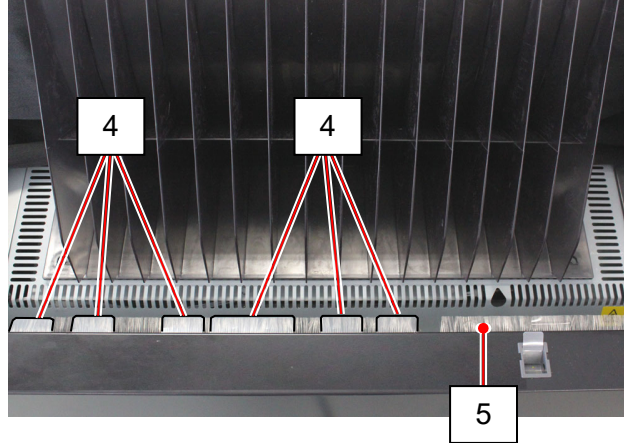

2. Clean 6 Exit Rollers (1) of the Paper Exit section to the arrow direction with the cloth which is wrung out the water.

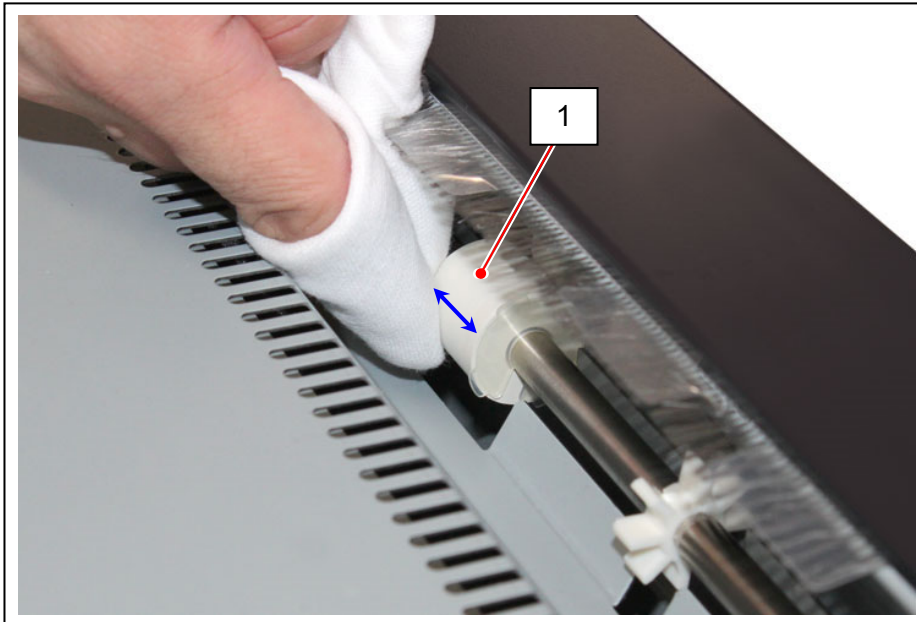

! NOTE

- (1) Clean the Exit Rollers when they are cold, such as "before turning on the printer".
- (2) Carefully clean the Exit Rollers so as not to damage the plastic sheet "Ring" (6) adhered to 4 Exit Rollers. (There is no Ring on 2 Exit Rollers in the center)

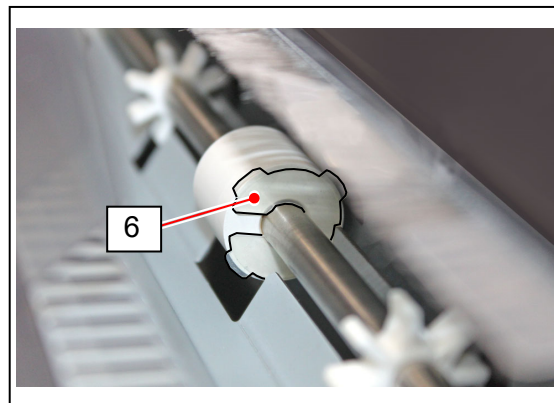

(See also next page)

! NOTE

Carefully clean the Exit Rollers so as not to damage the plastic sheets (4) and the Discharging Brush (5).

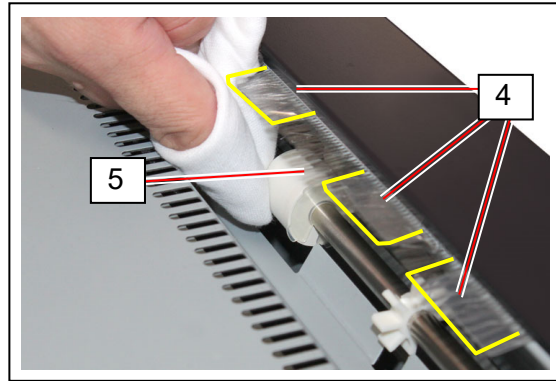

Reference

To clean the entire circumference of the Exit Rollers one time, clean the half circumference of the Exit Rollers and then turn off/on the printer. If so, the Exit Rollers are rotated, and another side (uncleaned side) can be cleaned.



4. 2 Scanner Unit (MFP Model)

4. 2. 1 Scan Glass, Feed Roller, Guide Plate

It is recommended to clean each Scan Glass, Feeding Rollers and Guide Plates as the scan/copy image may become defective if these parts are dirty.

NOTE

For ease of visual check, this document shows the Upper Unit fully open (not actual wide).

1. Turn off the Printer.
2. Lift up both sides (1) of the Scanner Unit.

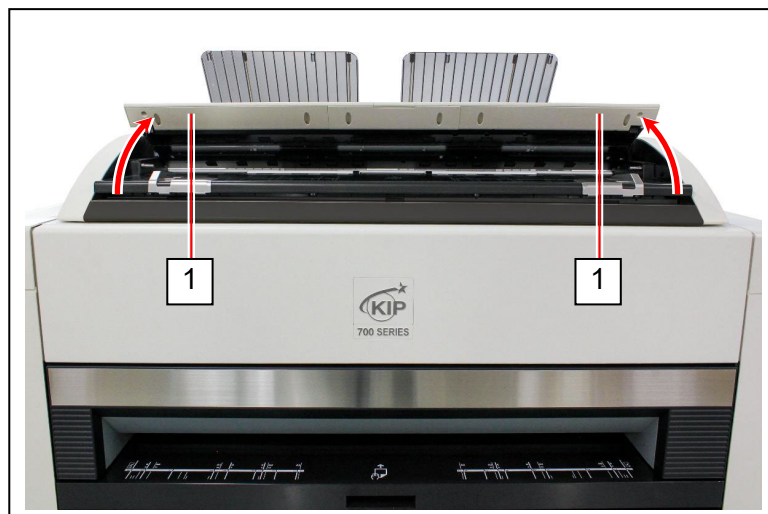

3. Gently wipe the Scan Glass (2) and Feed Rollers (white) (3) with a soft cloth. Equal mixture of water and neutral detergent can be used.

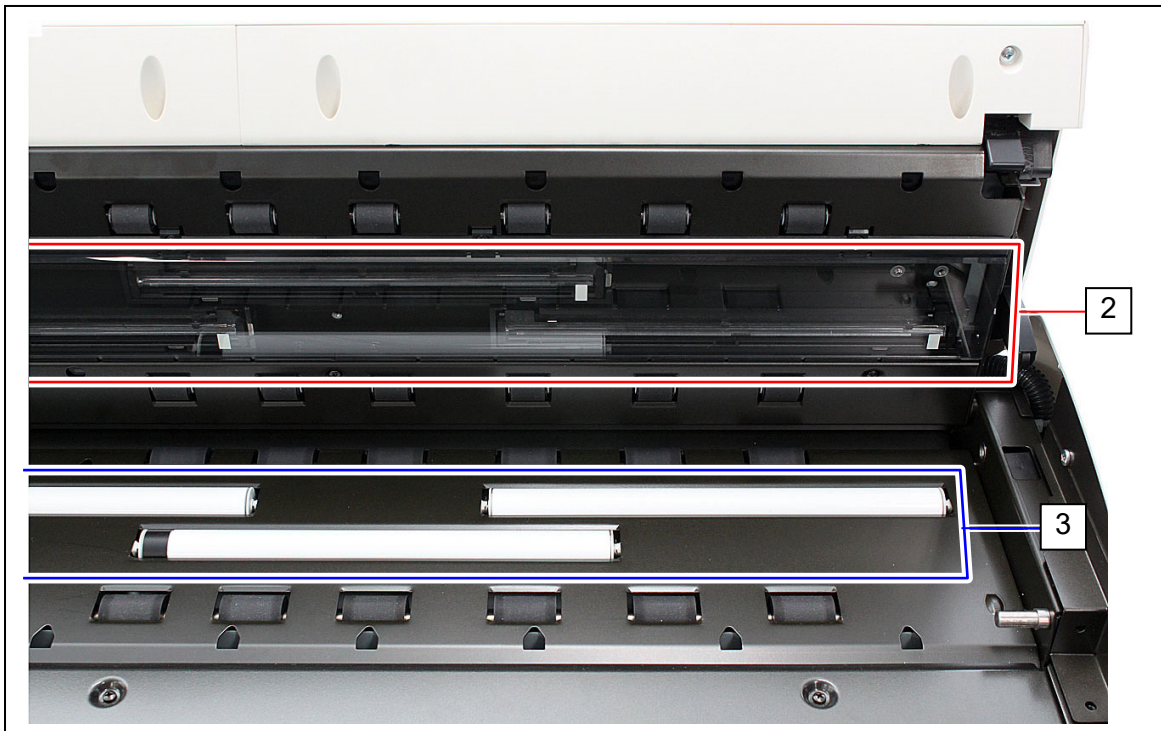

⚠ NOTE

Do not use organic solvent, glass cleaner and anti-static spray for the cleaning.

4. Wipe the Feed Rollers (rubber) (4) with a dry cloth.

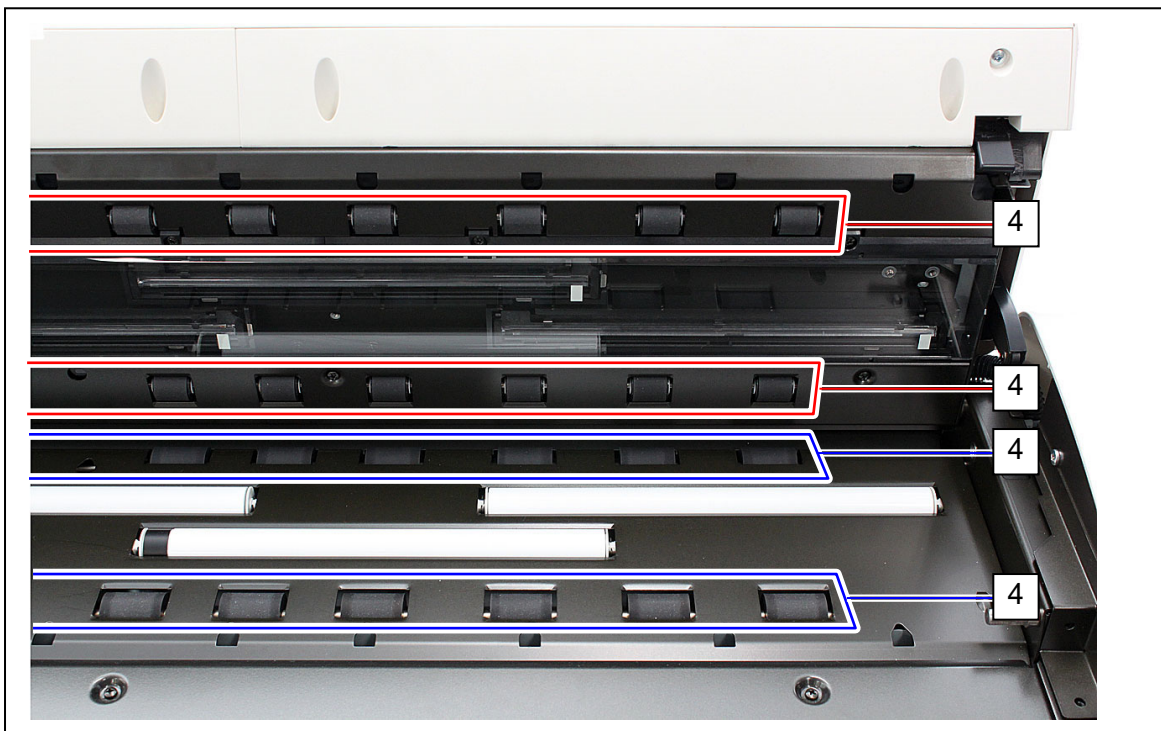

5. Wipe dry the Feeding Rollers.

6. Wipe the Upper Guide Plate (5) and the Lower Guide Plate (6) with a dry cloth.

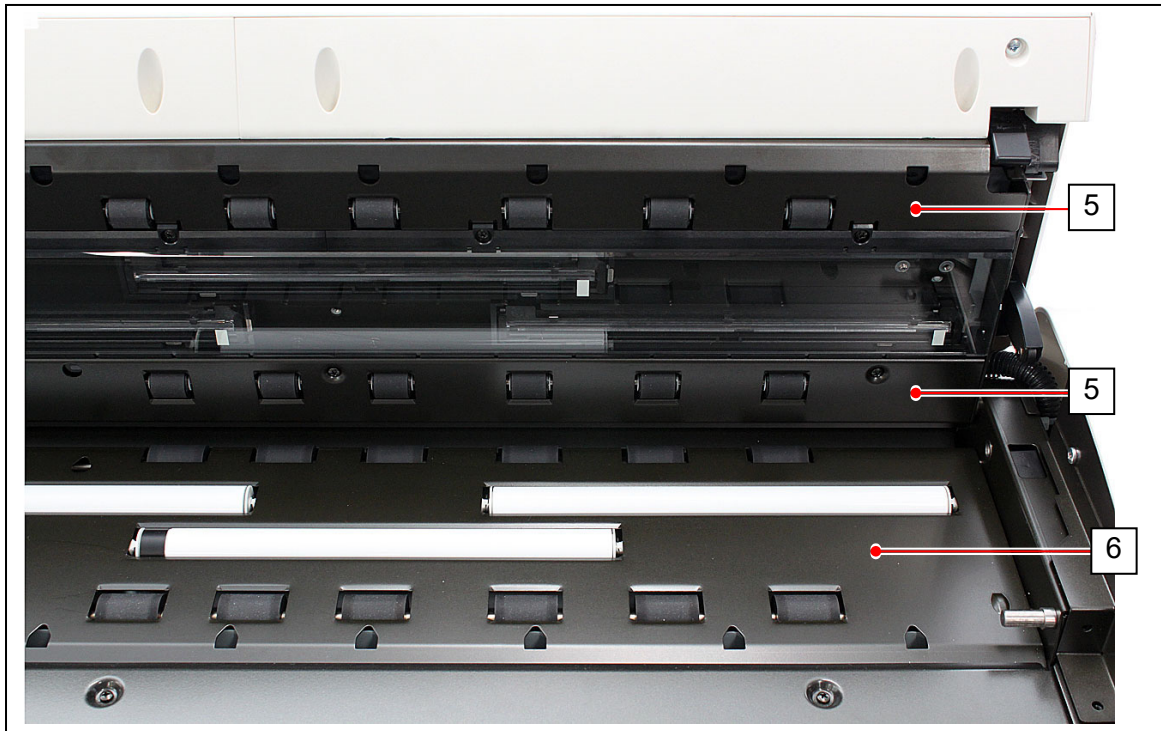

7. Gently press Scanner Unit down and firmly close it.



! NOTE

Press down Scanner Unit on both side to close it.
Do not close it by pressing only one side down.

4. 2. 2 Sensor

If Sensors are dirty, the original may be detected incorrectly.
Perform cleaning or as needed.

NOTE

For ease of visual check, this document shows the Upper Unit fully open (not actual wide).

1. Turn off the Printer.
2. Lift up both sides (1) of the Scanner Unit.

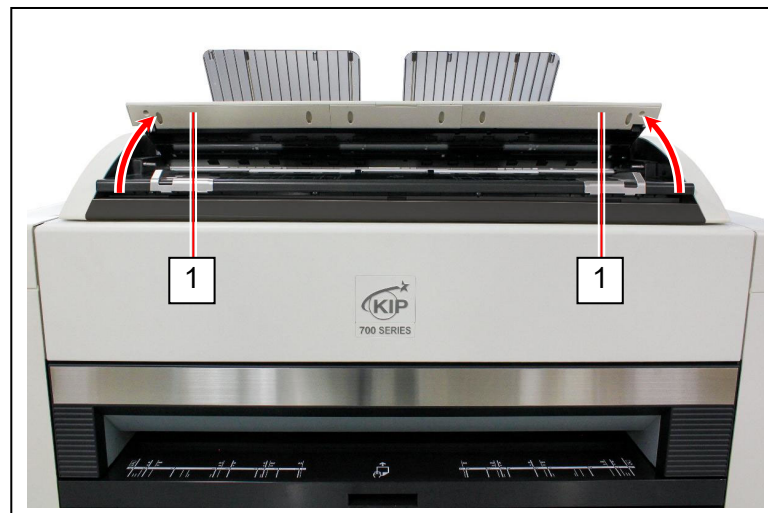

3. Gently wipe Sensors (2) with a dry cotton bud.

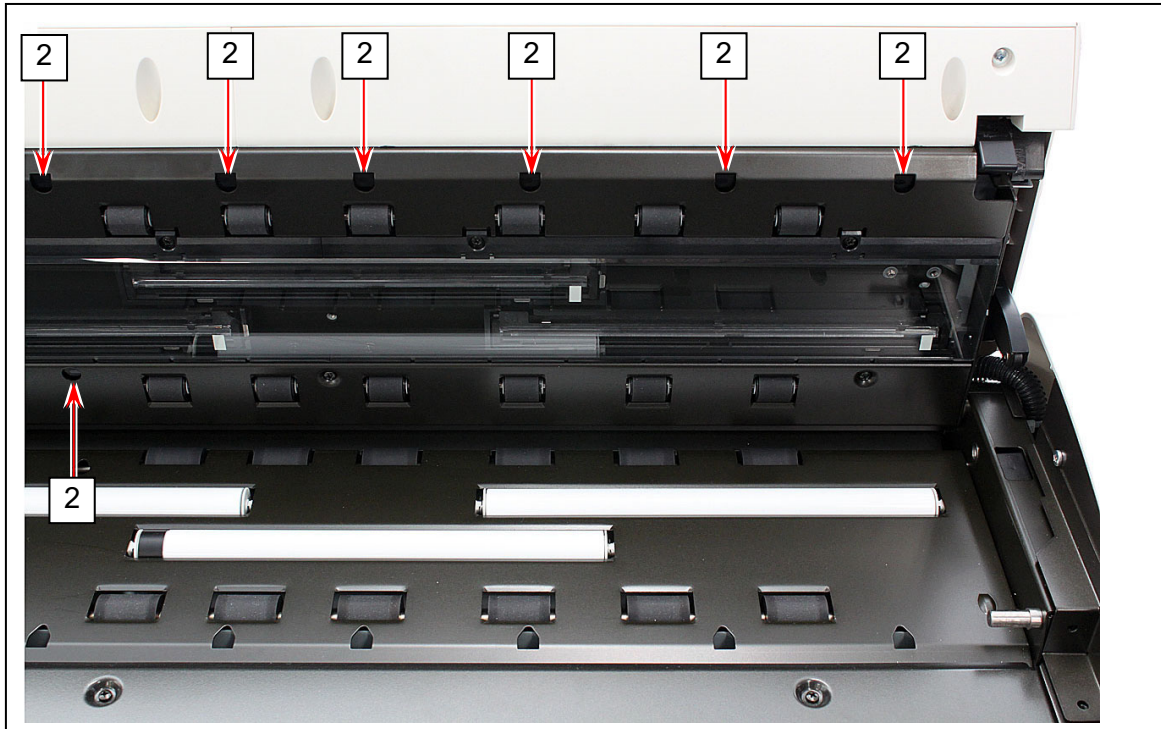

! NOTE

Do not use water, organic solvent, glass cleaner or antistatic spray for cleaning.

4. Gently press Scanner Unit down and firmly close it.



! NOTE

Press down Scanner Unit on both sides to close it.
Do not close it by pressing only one side down.

4.3 Touch Screen

1. Wipe the Touch Screen with a dry cloth.



! NOTE

Do not use water, alcohol, organic solvent, and glass cleaner for the cleaning.

KIP Global Network

America	
America	KIP America, Inc. 39575 W. 13 Mile Road Novi, MI 48377, U.S.A. Phone: +1-248-474-2900 www.kip.com
Canada	KIP Canada, Inc. 2735 Matheson Blvd. East, Suite 4, Mississauga, ON L4W 4M8, Canada Phone: +1-905-206-1177 www.kip.com
Europe	
UK / Europe	KIP Unit 8, Stephenson Close, Drayton Fields, Daventry, Northamptonshire, NN11 8RF, United Kingdom Phone: +44 (0) 1327 304 600 www.kip.com
Asia	
Japan	KIP Corporation 5-1 Yaguchi 1-Chome, Ota-ku, Tokyo 146-0093, Japan Tel: 03-3756-1101 www.kip-net.co.jp
Hong Kong / Macao / Chinese mainland	KIP Hong Kong Ltd. Unit 1508-9, 15/F, Tower A, Regent Centre, 63 Wo Yi Hop Road, Kwai Chung, N.T., Hong Kong Phone: 852 34269168
Chinese mainland	KIP (Beijing) Engineering Copying Equipments Co., Ltd. Room 21505, 12/F, Building 1, Xing Guang Global New Media Center, No.39 Chun He Road, Da Xing District, Beijing, China Phone: 86-10-60298900 www.kipchina.com
Korea	KIP Business Solution Korean Ltd. Room 1802, Halla Sigma Valley Bldg. 345-90, Gasan-dong, Geumcheon-gu, Seoul, 08588, Korea Phone: 82-2-785-8838 www.kipkr.com
South Eastern Asia	KIP Asia Co., Ltd. 200 Soi Baromratchachonnee 2 Bangbamru Bangkok, Thailand 10700, Thailand Phone: 662-4350022-6, 662-8818984-8 www.kip-asia.com
Taiwan	KIP Taiwan 108, Nan-Mei St., Kuei-Shan Taoyuan Phone: 886-3-321-0689 www.kiptaiwan.com

**WIDE FORMAT COLOR PRINTER / MFP
KIP 700 Series
Hardware Operation Guide**

Ver. A.4 (Issued on May 19, 2023)

**Published by Katsuragawa Electric Co., Ltd.
21-1 Shimomaruko 4-Chome,
Ota-ku, Tokyo 146-8585, Japan**

Please note that some articles, illustrations and photographs might be partially different from the actual machine because of the modification of machine and so on.

© 2021 Katsuragawa Electric Co., Ltd.

No part of this publication may be copied, reproduced or distributed in any form without express written permission from Katsuragawa Electric Co., Ltd.



700 C SERIES



KIP 700 C Series
User Manual

For SN 1487xxxx

Thank you for purchasing the KIP 700 Series.

This Hardware Operation Guide contains functional and operational explanations for the KIP 700 Series.

Please read this Hardware Operation Guide carefully before using the Printer.

Please keep this Hardware Operation Guide for future reference.

1. When this product is installed in North America.

This product complies with part 15 of the FCC Rules. Operation is subject to the following two conditions: (1) This product may not cause harmful interference, and (2) this device must accept any interference received, including interference that may cause undesired operation.

FCC CAUTION

Changes or modifications not expressly approved by the party responsible for compliance could void the user's authority to operate the product.

Note: This product has been tested and found to comply with the limits for a Class A digital equipment, pursuant to part 15 of the FCC Rules. These limits are designed to provide reasonable protection against harmful interference when the product is operated in a commercial environment. This product generates, uses, and can radiate radio frequency energy and, if not installed and used in accordance with the instruction manual, may cause harmful interference to radio communications. Operation of this product in a residential area is likely to cause harmful interference in which case the user will be required to correct the interference at his own expense.

This product complies with Part 15 of FCC Rules and Industry Canada licence-exempt RSS standard(s). Operation is subject to the following two conditions: (1) this product may not cause interference, and (2) this product must accept any interference, including interference that may cause undesired operation of this product.

Le présent appareil est conforme aux la partie 15 des règles de la FCC et CNR d'Industrie Canada applicables aux appareils radio exempts de licence. L'exploitation est autorisée aux deux conditions suivantes : (1) l'appareil ne doit pas produire de brouillage, et (2) l'utilisateur de l'appareil doit accepter tout brouillage radioélectrique subi, même si le brouillage est susceptible d'en compromettre le fonctionnement.

Contains FCC ID: VP8-13551

Contains IC: 7391A-13551

2. When this product is installed in Europe

This product complies with the requirements in CISPR 32 for a Class A computing equipment. Operation of this product in a residential area may cause unacceptable interference to radio and TV reception requiring the operator to take whatever steps are necessary to correct the interference.

Do not install product around other electronic equipment or other precision instruments. Other equipment may be effected by electrical noise during operation.

If the product is installed near other electronic equipment, such as a TV or a radio, interference to said equipment, such as noise or flickering, may occur.

Use a separate power line and install the PRINTER as far as possible from said equipment.

KIP 700 Series is an ENERGY STAR qualified multifunction device.



The International ENERGY STAR® Office Equipment Program is an international program that promotes energy saving through the penetration of energy efficient computers and other office equipment. The program backs the development and dissemination of products with functions that effectively reduce energy consumption. It is an open system in which business proprietors can participate voluntarily. The targeted products are office equipment such as computers, monitors, printers, facsimiles, copiers, scanners, and multifunction devices. Their standards and logos are uniform among participating nations.

The symbol shown indicates that this product conforms to Directive 2012/19/EC of the European Parliament and the council of 4 July 2012 on waste electrical and electronic equipment (WEEE) and does not apply to countries outside of EU.



Only For EU Member States

Das Gerät ist nicht für die Benutzung am Bildschirmarbeitsplatz gemäß BildscharbV vorgesehen.

The symbol shown indicates that this product conforms to SJ/T11364-2006 of People's Republic of China Electronic Industry Standard and does not apply to countries outside of People's Republic of China.



The symbol shown indicates that this product conforms to GB 18455-2001, SJ/T 11364-2006 of National Standard of the People's Republic of China and does not apply to countries outside of People's Republic of China.

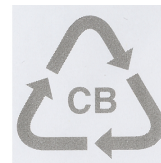

Safety Warning

The following warnings are very important in order to safely use this product.
These notes are important in preventing danger to the operator or operation of the printer.

The following symbols are found throughout the USER'S Manual and have the following meaning:



WARNING

This WARNING mark means that there is a possibility of death or serious injury if you ignore or do not follow the said instruction.



CAUTION

This CAUTION mark means that there is a possibility of injury or physical damage if you ignore or do not follow the said instruction.

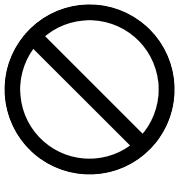

When marked with this symbol, "DO NOT ATTEMPT".



When marked with this symbol, "pay close attention to".



There are extremely hot parts inside.
Do not touch any parts, or you will be burnt.



WARNING

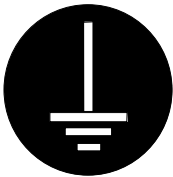

Ground the product with a correct ground source or you may be electrically shocked.



1. The Power source should be as follows: 208V to 240V plus 6% or minus 10%, 50/60Hz, 16A or higher
2. Use a circuit with a dedicated breaker.
3. Install the product as close to the wall outlet as possible.
4. If you wish to move the printer, please contact your service personnel.



1. Do not remove the screw and do not open the cover if not instructed to do so in this User's Manual. If you ignore this warning, you may be burnt or receive an electric shock due to a hot item or electrically charged part inside of the printer.
2. Do not disassemble or tamper with the printer. It may result in a fire or an electrical shock.

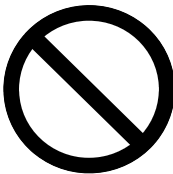

1. Do not plug in the printer into a multi-wire connector in which some other equipment is plugged into. It may cause a fire due to outlet overheating.
2. Do not damage the Power Cord by stepping on or placing heavy items on it. If the Power Cord is damaged, it may cause a fire or you may receive an electric shock. **REPLACE THE CORD IF DAMAGED!**

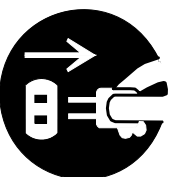

1. Do not put a flower vase, a flowerpot or any water-filled item on the product. Spilt water could cause a fire or an electric shock.
2. If the product generates an abnormal smell or noise, turn it off and unplug it from the wall electrical outlet immediately.



Do not throw the toner into a fire or other sources of heat, as it can explode.



CAUTION

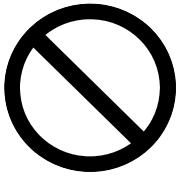

1. Do not install the printer in a humidified room or a dusty room. Also, do not install the printer on an unstable floor as injuries may occur.
2. This equipment is not suitable for use in locations where children are likely to be present.

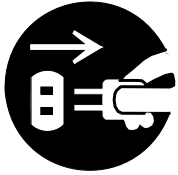

1. Unplug the printer before you move it. The power cord may be damaged and it may result in a fire or electric shock.
2. If you do not use the printer for a long duration (holidays, company shutdown) turn off and unplug the printer from the outlet for safety.

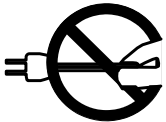

Do not pull the cord when you unplug the printer as you may damage the Power Cord.



There are hot items inside of the printer. Take great care not to touch these items when you remove mis-fed media.



Ventilate the room well if you print in a small area.

POWER CORD INSTRUCTION

The installation of (or exchange to) a power plug which fits in the wall outlet of the installation location shall be conducted in accordance with the following:



WARNING

Select a power plug which meets the following criteria;

- The plug has a voltage and current rating appropriate for the product's rating marked on its name plate.
- The plug meets regulatory requirements for the area.
- The plug is provided with a grounding pin or terminal.

If the appropriate plug does not fit the wall outlet in the installation, the customer shall install an appropriate outlet.

Connector Type:

Configuration	Standard	Rating	Usually found in
	IEC60320:C19	20A 250V (UL) 16A 250V (IEC)	

Plug Type: Model Rating 208V-240V

Configuration	Standard	Rating	Usually found in
	NEMA6-20	20A 250V	North America (UL Listed)
	CEE7/7	16A 250V	European countries
	KS C 8305	16A 250V	Korea
	AS/NZS 3112	16A 250V	Australia New Zealand
	GB1002 GB2099.1	16A 250V	China
	IRAM 2073	16A 250V	Argentina

Cord Type

Standard	Rating	Usually found in
SJT 3X12AWG Long <4.5m	20A 250V	North America (UL Listed)
HO5VV-F 3X1.5mm ²	16A 250V	European countries Argentina
RVV 3X1.5mm ²	16A 250V	China

Chapter 1

Introduction

	Page
1.1 Installation Requirements	1- 2
1.2 Originals Prohibited from Duplication	1- 3
1.3 Features	1- 4
1.4 Specifications	1- 5
1.4.1 Printer	1- 5
1.4.2 Scanner (MFP model)	1- 7
1.5 Appearance	1- 8
1.5.1 Front view	1- 8
1.5.2 Left side view	1- 9
1.5.3 Right side view	1- 10
1.5.4 Rear view	1- 11
1.6 Specifications for Print Media	1- 12
1.6.1 Papers not to be used	1- 12
1.6.2 Paper Storage	1- 13
1.6.3 Environmental Considerations	1- 14
1.7 Specifications for Originals	1- 15
1.7.1 Original Standards	1- 15
1.7.2 Special Documents	1- 15
1.7.3 “Do Not Scan” Originals	1- 16

1. 1 Installation Requirements

The following conditions are required for installation of the equipment.



1. Power source should be rated as:
208V - 240V plus 6% or minus 10%, 50/60Hz, 16A or higher
2. The equipment must be on an exclusive circuit.
3. The outlet must be near the equipment and easily accessible.



1. Make sure to connect this equipment to a grounded outlet.
2. For PLUGGABLE EQUIPMENT, the socket-outlet shall be installed near the equipment and shall be easily accessible.



1. The installation site must not have open flames, dust or ammonia gases.
2. Not to be installed near solvent based printers, corrosive gases or devices that emit them.
3. The equipment must not be exposed to the air vents from air conditioners.
It may affect the image quality.
4. The equipment should not be exposed to the direct sunlight.
Please draw curtains to block any sunlight.
When you open the Upper Unit to remove a mis-feed, do not expose the Photoconductive Drum to strong (intense) light as this will damage the Drum.



Ventilate the room, if required.

The site temperature range = 10 to 30 degrees Centigrade, with the humidity between 15% to 80% RH. (NON-CONDENSING)

Keep the printer away from water sources, boilers, humidifiers, refrigerators, kerosene (oil) stoves or other printers which emit gases.

Keep ample room around the equipment to ensure comfortable operation.

(Refer to the following figure.)

The equipment must be leveled and the floor strength must be ample to sustain the weight of the equipment.

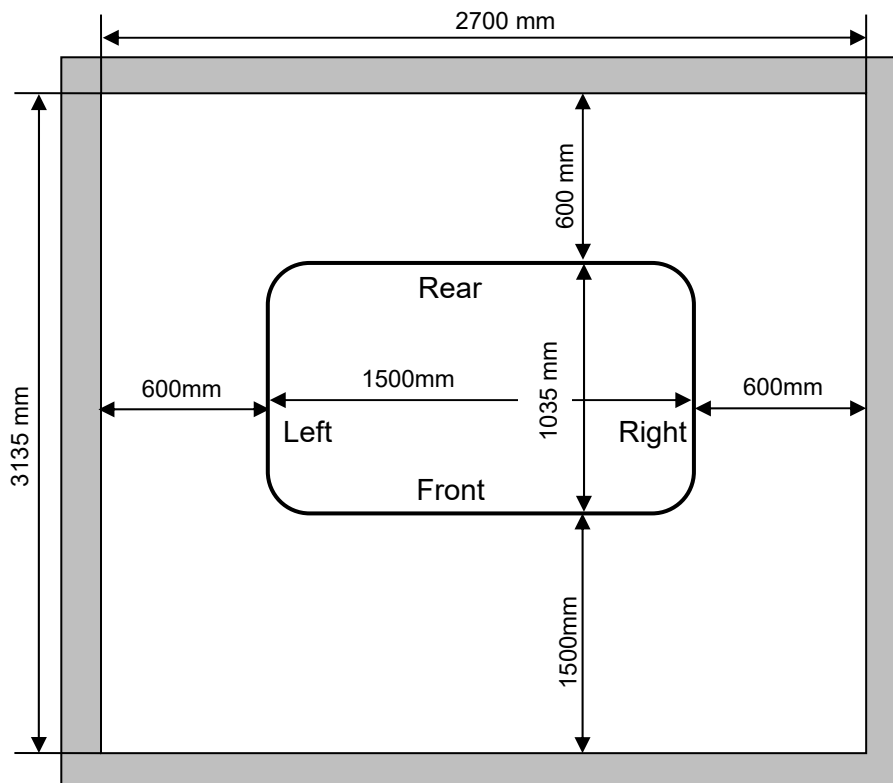

1.2 Originals Prohibited from Duplication

It may be illegal to duplicate or copy certain types of originals and you may be punished by local or regional laws, if copies are made of these types of documents.

Please be aware of your local or regional laws and which originals they forbid you to duplicate.

Some Examples:

[Originals prohibited from copying by law(s)]

1. Do not copy Currency (Bill, Money, Bank Note, etc.), Government issued Negotiable Instruments (National Bonds, Security, Local Debt Bonds, etc.).
2. Do not copy Foreign Currency or Foreign Negotiable Instruments.
3. Do not copy unused postal stamps or government postcards without permission to make replica from said Governments.
4. Do not copy Government issued revenue stamps, certificate stamps that are prescribed by Liquor Tax Act or the Commodity Tax Act.

[Special items which require your attention]

1. The government issues warnings if you are to copy private issued securities (stock certificate, draft, check, goods ticket, etc.), commutation ticket or book of tickets, excluding that some specific company copies such originals as many as it requires for its own business.
2. We recommend you not copy originals as government issued passports, public or private issued licenses, automobile inspection certification, ID and tickets passes or meals.

[Originals protected by the copyright]

It is prohibited to copy originals such as books, music, paintings, printed copies, maps, drawings, movie posters and pictures which are protected by the copyright laws. Please refer to your local or regional laws.

1.3 Features

- (1) Electro Photographic, full color LED printer/MFP using KIP Contact Control Technology with KIP Contact Array Charging and KIP Image Smoothing Technologies.
- (2) The **KIP 700 Series** have a wide product range to meet various customers' requirements.
- (3) Supported widths and lengths:
 - Maximum width : 914mm (36")
 - Minimum width : 279.4mm (11")
 - Maximum length : 6,000mm (for A0/36")
 - Minimum length : 210mm (8.5")
- (4) **KIP 730 / 740** print rate per minute:
 - 6.0 D size (Eng) or 5.7 A1 size
 - 60mm/sec in color / monochrome, regardless of image type
- (5) Transfer Belt Technology permits accurate color registration.
- (6) Prints are ready for immediate use with high durability to include UV and water resistant.
- (7) 15.6 inch multi-touch panel allows for tablet-like operation and image viewing.
- (8) Easy access to the USB port permits quick prints using easy touch panel functions.
- (9) Feature rich, KIP System K Software applications and drivers.

1.4 Specifications

1.4.1 Printer

Subject	Specification												
Model	KIP 700 Series 2-Roll Printer / MFP (W/O Bypass Feeder)												
Type	Console, full color and monochrome print/scan												
Printing method	LED Array Electro Photography, Dry Toner												
Color	CMYK												
Photoconductor	Organic Photoconductive Drum												
Print Productivity	60mm/sec. (6.0 D/min, 3.1 E/min.) : Color and monochrome (5.7 A1/min, 2.9 A0/min.) : Color and monochrome												
Exposure method	Multi-Level (9 levels) LED Print Head												
Resolution	600dpi x 2400dpi												
Print width	Maximum : 914mm (36 inches) Minimum : 279.4mm (11 inches)												
Print length	Maximum : <table border="1" data-bbox="507 772 1401 891"> <tbody> <tr> <td>Plain Paper / Bond</td> <td>5x standard portrait</td> <td>6000mm in case of A0/36"</td> </tr> <tr> <td>Tracing Paper / Vellum</td> <td>1x standard portrait</td> <td></td> </tr> <tr> <td>Film</td> <td>1x standard portrait</td> <td></td> </tr> <tr> <td>Glossy Paper</td> <td>1x standard portrait</td> <td></td> </tr> </tbody> </table> Minimum : 210mm (8.5 inches) NOTE : If the print is longer than the above, KIP does not guarantee image quality or the reliability of the media feeding system.	Plain Paper / Bond	5x standard portrait	6000mm in case of A0/36"	Tracing Paper / Vellum	1x standard portrait		Film	1x standard portrait		Glossy Paper	1x standard portrait	
Plain Paper / Bond	5x standard portrait	6000mm in case of A0/36"											
Tracing Paper / Vellum	1x standard portrait												
Film	1x standard portrait												
Glossy Paper	1x standard portrait												
Warm up time	Less than 5 minutes (At 23 degrees centigrade, 60% RH and 208V)												
Fusing method	Heat roller fusing												
Development	Contact, mono component non-magnetic development system												
Drum charging	Charging Roller (KIP CAC Technology)												
Transfer	Transfer roller												
Separation	Electrostatic separation (AC)												
Media feeding method	Automatic - 2 rolls												
Rating power	208 to 240V (+6% to -10%), 14A and 50/60Hz												
Interface	Ethernet 10BASE-T, 100 BASE -TX, 1000 BASE-T USB 2.0/3.0 (5VDC max)												
Power consumption	230V, 50/60Hz Printing 1.4 kW (Average) Warm up 3.5 kW (Average) Ready 0.5 kW (Average) Cold Sleep 3.2 W (Average)												
Acoustic noise	Less than 65dB (Printing) NOTE : Impact noise such as cutting sound is excluded. Less than 60dB (Ready) The highest sound pressure according to EN ISO 7779 is 70dB (A) or less.												

Subject	Specification
Dimensions	KIP 730: 1500mm (W) x 1035mm (D) x 888mm (H) KIP 740: 1500mm (W) x 1035mm (D) x 1033mm (H) NOTE: Touch panel and upper trays are not included.
Weight	KIP 730: ~370 kg KIP 740: ~392 kg
Media (Recommended)	Bond/Plain paper - 67g/m ² to 90g/m ² Tracing paper - 75g/m ² Gloss - 120g/m ² NOTE: Refer to regional media guide(s)
Environmental condition	Standard Environment : 23°C and 60% Temperature 10 to 30 degrees centigrade Humidity 15 to 80% RH
Storage of consumables	Print media Wrap the media to prevent access of moisture Toner Keep the bottles away from direct sunlight, and store between 0 - 35 °C and 10 - 85% RH.

! NOTE

Specifications are subject to change without notice.

1. 4. 2 Scanner (MFP model)

Subject	Specification
Scanning method	Contact Image Sensor (CIS) (5 pieces of A4 sized CIS)
Light source	LED (R/G/B)
Scanning speed (600 dpi, normal quality) (max)	Monochrome : 65mm/s Grayscale : 65mm/s Color : 22mm/s NOTE: Actual speed may vary by the scan software.
Setting of original	Face up
Starting point of scan	Center
Scan width	Max: 914.4mm / 36" Min : 210mm
Scan length	Max: 6,000mm / 19.7ft (Including the margin area) Min : 210mm / 8.5" (Including the margin area) NOTE : If the original is longer than 6,000mm, image quality or the feeding reliability is not guaranteed.
Optical resolution	600dpi
Digital resolution	200 / 300 / 400 / 600 dpi
Original transportation	Sheet through type
Transportable original thickness	Max: 1.60mm Min : 0.05mm NOTE : Suggest to change "It does not guarantee both scan/copy image quality and original feeding reliability in case the original is non-standard size one of which thickness is 0.25mm or thicker.

NOTE

Specifications are subject to change without notice.

1.5 Appearance

1.5.1 Front view



	Name of part	Function																								
1	Print Tray	These trays catch ejected prints.																								
2	Scanner Unit (MFP model)	Read the original with this unit when you make scan or copy.																								
3	Scan Abort Button (MFP model)	While scanning: emergency stop At Standby position: eject																								
4	Start Button (MFP model)	Starts scanning if the controlling software requires user intervention.																								
5	User Interface	This is a Touch Screen, and many kinds of user operation are available. PLEASE DO NOT push the LCD area too strong.																								
6	Roll Deck	Roll media can be loaded here.																								
7	Status Indicator	LED indicator indicates the following printer status. <table border="1" data-bbox="555 1675 1409 1937"> <thead> <tr> <th>Color</th> <th>Condition</th> <th>Status</th> </tr> </thead> <tbody> <tr> <td>Green</td> <td>Light</td> <td>Ready, Printing</td> </tr> <tr> <td>Green</td> <td>Blink</td> <td>Warming up.</td> </tr> <tr> <td>Orange</td> <td>Light</td> <td>Operator Call Error</td> </tr> <tr> <td>Red</td> <td>Light</td> <td>Service Call Error</td> </tr> <tr> <td>Blue</td> <td>Light</td> <td>Warm sleep</td> </tr> <tr> <td>Blue</td> <td>Light</td> <td>Cold sleep</td> </tr> <tr> <td>light purple</td> <td>Light</td> <td>When printer is power-off and print controller is still power on.</td> </tr> </tbody> </table>	Color	Condition	Status	Green	Light	Ready, Printing	Green	Blink	Warming up.	Orange	Light	Operator Call Error	Red	Light	Service Call Error	Blue	Light	Warm sleep	Blue	Light	Cold sleep	light purple	Light	When printer is power-off and print controller is still power on.
Color	Condition	Status																								
Green	Light	Ready, Printing																								
Green	Blink	Warming up.																								
Orange	Light	Operator Call Error																								
Red	Light	Service Call Error																								
Blue	Light	Warm sleep																								
Blue	Light	Cold sleep																								
light purple	Light	When printer is power-off and print controller is still power on.																								

1. 5. 2 Left side view

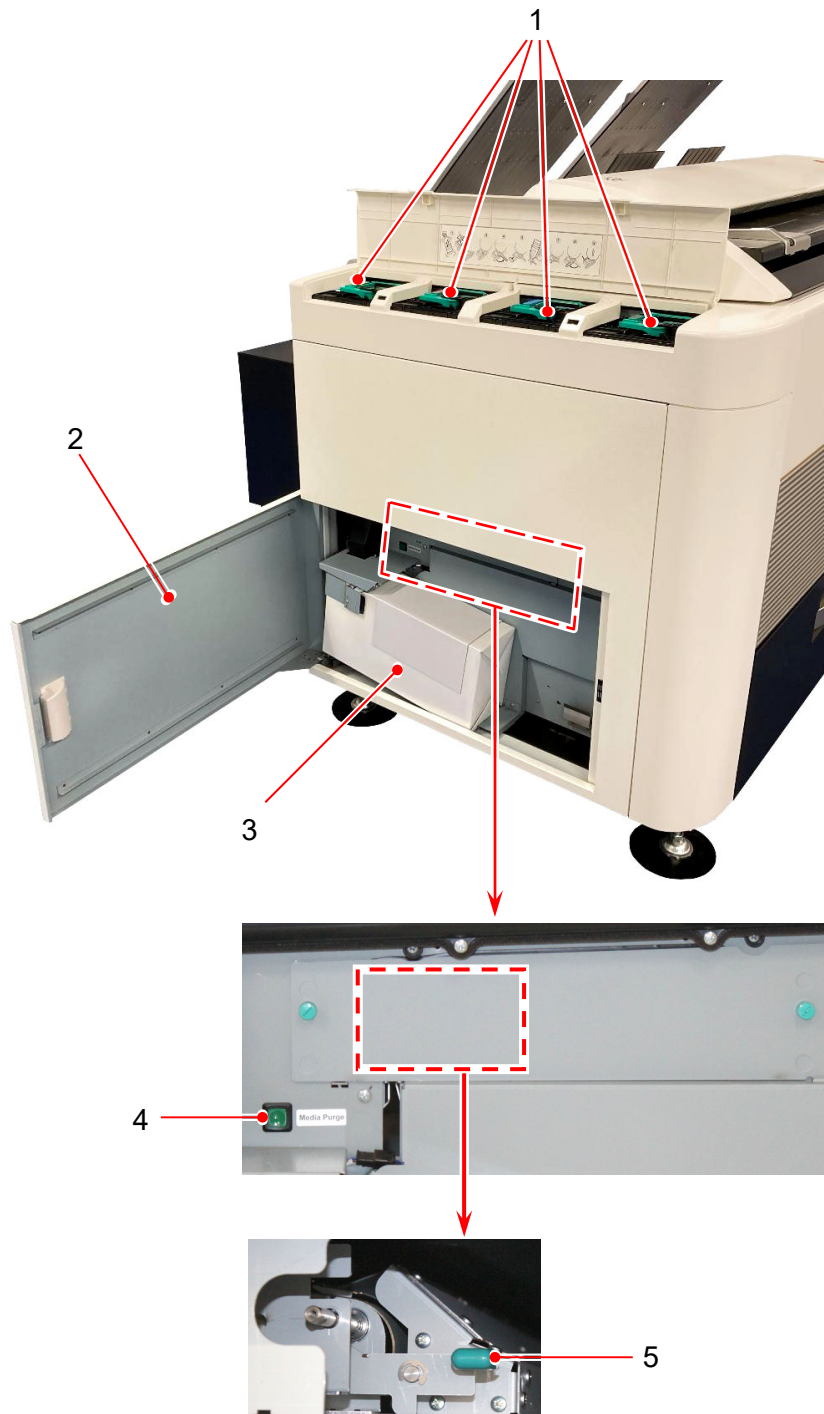

	Name of part	Function
1	Toner Supply Port	Toner Cartridge (C, M, Y, K) to be set here to add toner to the system.
2	Left Side Door	Access Waste Container, Purge Switch and Feeder Release Knob.
3	Waste Toner Box	Collects the wasted toner.
4	Purge Switch	After removing jammed sheets, press this switch to eject remaining sheet from the printer.
5	Feeder Release Knob	Unlocks the Feeder Unit to clear misfeeds.

1. 5. 3 Right side view



	Name of part	Function
1	USB Port	Your USB flash memory can be used here. (5VDC max.)
2	Power Switch	Turn on/off the Printer.

1. 5. 4 Rear view



	Name of part	Function
1	Fuser Cover	Prints come from the opening on this. Open the Fuser Cover when you remove the misfeeds inside the Fuser Unit.
2	Breaker	It is possible to shut off supplying the AC power.
3	Inlet Socket	Connect the Power Cord here.

1. 6 Specifications for Print Media

1. 6. 1 Papers not to be used

Do not use the following kinds of printing paper. Doing so may damage the print engine.

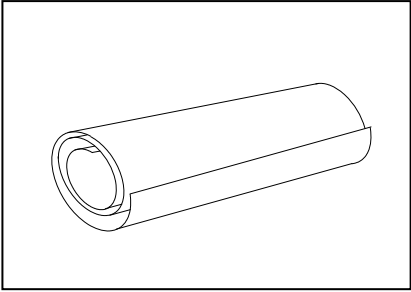
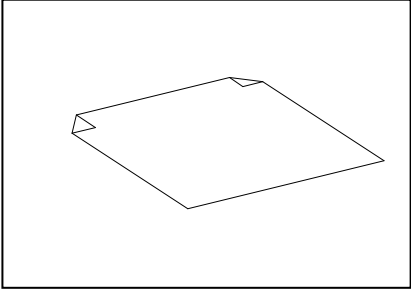
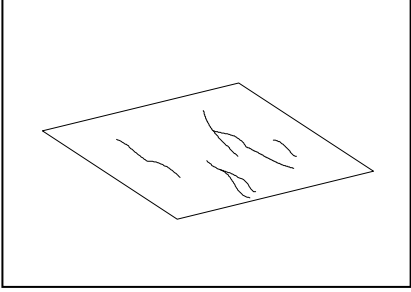
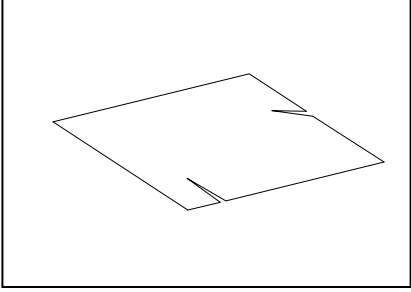
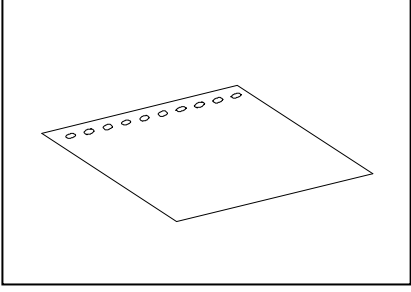
Excessively curled (a diameter of 50 mm or less)	
Folded	
Creased	
Torn	
Punched	

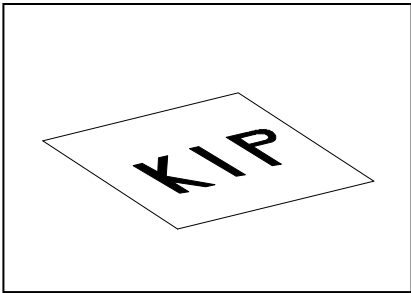
Pre-printed	
Extremely slippery	
Extremely sticky	
Extremely thin and soft	
OHP Film	

CAUTION

Do not use the paper with staple, or do not use such conductive paper as aluminium foil and carbon paper.

The above may result in a danger of fire

NOTE

- (1) Print image may become light if printed on a rough surface of the paper.
- (2) Print image may become defective if the print paper has an excess curl.
- (3) It will become a cause for paper mis-feed, defective print image or paper creasing if you use a paper that does not satisfy the specification.
- (4) Do not use a paper of which surface is very special, such as thermal paper, art paper, aluminium foil, carbon paper and conductive paper.
- (5) Do not use papers with unpacked (exposed in high / low temperature & humidity) in a long period. Such papers may result in mis-feed, defective image or paper creasing.
- (6) Tracing paper exposed to air over a long period tends to cause a defective printing. Removing one round on the surface of the tracing roll paper from the beginning is recommended.
Refer to [2.3 Replacing Roll Media].

1. 6. 2 Paper Storage

Keep the paper in the custody taking care of the following matters.

1. Do not expose the paper to the direct sunlight.
2. Keep the paper away from high humidity. (It must be less than 70%)
3. Put the paper on a flat place
4. If you will keep the paper in the custody, which you have already unpacked, put it into the polyethylene bag to avoid the humidity.

1. 6. 3 Environmental considerations

Take the necessary actions for environmental conditions as shown below.

Humidity(%)	Possible problem	Necessary treatment
Low ↑	“Void of image”, “crease of paper” and other problems occurs when you print with plain paper and tracing paper.	1. Install the humidifier in the room, and humidify the room air. 2. Remove the paper from the machine right after the completion of print, and keep it in a polyethylene bag.
40%	“Void of image” occurs when you print with tracing paper.	If you will not make print soon, remove the tracing paper from the machine and keep it in a polyethylene bag.
70%		Remove the paper from the machine after everyday use, and keep it in a polyethylene bag.
High ↓	“Void of image”, “crease of paper” and other problems occurs when you print with plain paper and tracing paper.	Remove the paper from the machine right after the completion of print, and keep it in a polyethylene bag.

! NOTE

“Void of image” and “crease of paper” will occur in case of extremely high or low humidity.

Normal Print

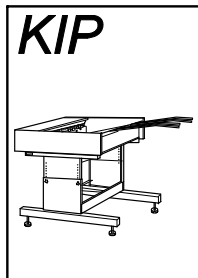

If the media is humidified;

Crease of paper

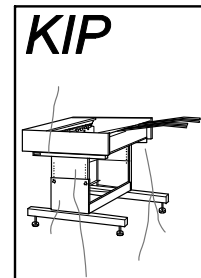

Normal Print



If the media is humidified;

Loss of image



1.7 Specifications for Originals

A scan original must satisfy the following specifications.

Thickness	0.05mm to 1.60mm
Width	210mm to 914.4mm
Length	210mm to 6,000mm

NOTE :

1. Image quality for an original with 0.25mm or thicker is guaranteed only in a standard size even the scanner physically accepts it.
2. Image quality for an original over 6,000mm in length is not guaranteed.

1.7.1 Original Standards

- (1) The width of original must range from 8.5" to 36" (210mm to 914.4mm).
- (2) The length of original must range 8.5" (210mm) to 6,000mm
- (3) The thickness of original must range from 0.05mm to 0.25mm.
- (4) The shape of original must be square, and it must be standard sized.
- (5) The type of original must belong to any of the followings.
 - Plain paper
 - Coated paper (High or middle class plain paper is coated with the paint.)
 - Tracing paper
 - Pansy Trace Paper (Both sides of the film is sandwiched between Tracing paper.)
 - Film
 - Newspaper
 - Cardboard paper

1.7.2 Special Documents

The following kinds of originals are "special". It is possible to scan them, **but the image quality and feed reliability are not guaranteed.**

- (1) The type of original is acceptable, but the thickness and type may not be:
 - Booklets
 - Original with a Hanger
 - Cut and Pasted originals
- (2) These original may not damage the scanner, but these types are NOT recommended: following ones.
 - Cloth
 - Aluminium Kent Paper

1. 7. 3 “Do Not Scan” Originals

It is impossible to use the following types of originals because they are likely to damage the scanner.

Do not scan the following kinds of original, because you may damage the original or scanner itself!

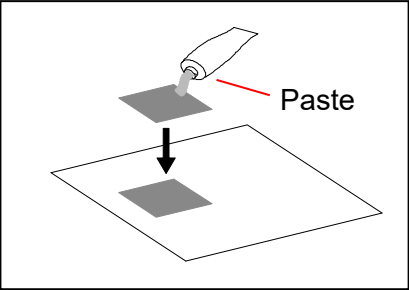
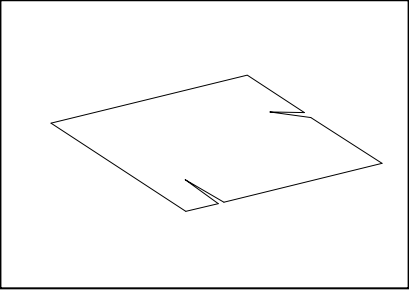
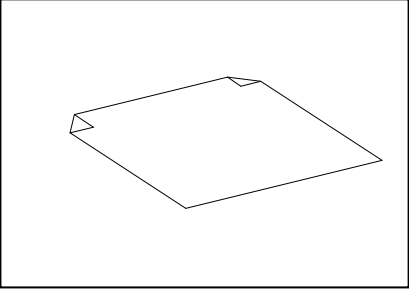
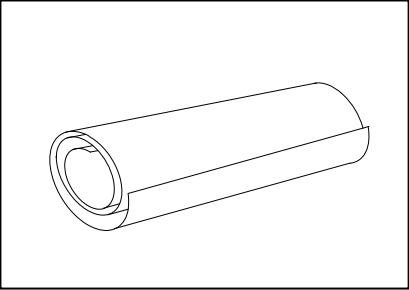
Sticked with paste	 <p>The diagram illustrates the process of sticking a piece of paper. A brush is shown applying a substance labeled 'Paste' to a small square on a larger sheet of paper. An arrow points from the brush to the paste, and another arrow points from the paste to the paper.</p>
Torn	 <p>The diagram shows a rectangular piece of paper with jagged, irregular edges, indicating it has been torn.</p>
Folded (Leading edge)	 <p>The diagram shows a rectangular piece of paper folded in half, with the leading edge (the edge closest to the scanner) clearly visible.</p>
So much curled (Diameter is smaller than 50mm.)	 <p>The diagram shows a piece of paper rolled into a tight cylinder, with the diameter of the roll being smaller than 50mm.</p>

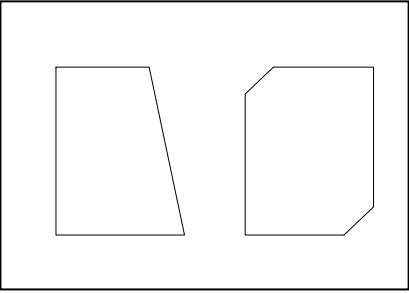
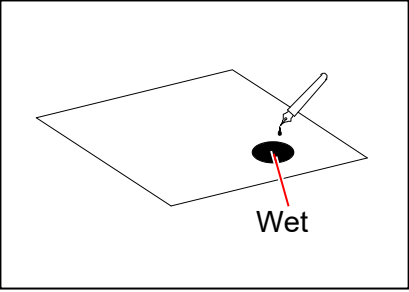
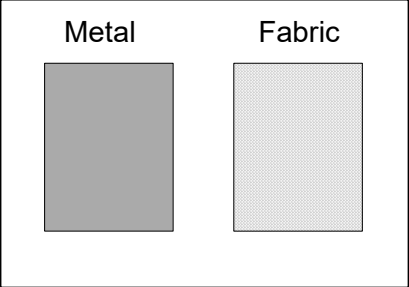
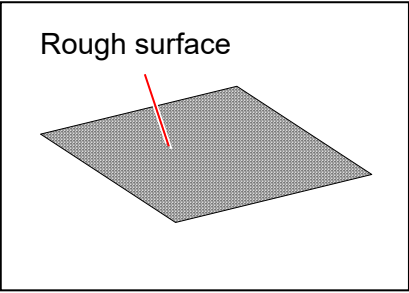
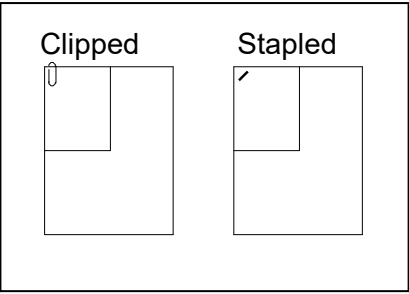
<p>Not square</p>	
<p>Wet image</p>	
<p>Made of metal or fabric</p>	<p>Metal Fabric</p> 
<p>Rough surface (Carbon paper for example)</p>	<p>Rough surface</p> 
<p>Clipped or stapled</p>	<p>Clipped Stapled</p> 

The following kinds of originals can be read with using a carrier sheet.

However, the image quality and feed reliability are not guaranteed.

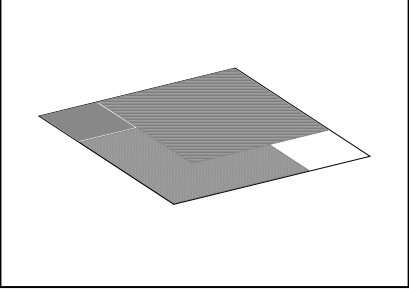
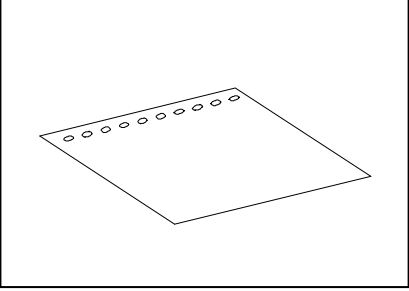
Patched	
Punched	

Chapter 2

Basic Operations

	page
2.1 Turning on the Printer	2- 2
2.2 Turning off the Printer	2- 4
2.3 Replacine Roll Media	2- 6
2.4 Trim Cut	2-16
2.4.1 Auto Cut	2-16
2.4.2 Manual Cut	2-17
2.5 Toner Supply	2-21
2.6 Replacing Toner Receptacle	2-27
2.7 Attaching the Tray C (Asian model only)	2-34
2.8 Copying (MFP model)	2-36
2.9 Stop of Scan or Copy (MFP model)	2-38

2. 1 Turning on the Printer

1. Plug the Printer to an exclusive wall outlet.

WARNING

Please confirm the outlet satisfies the following condition before plugging the Printer into.

208V-240V (+6% to -10%), 16A, and 50/60Hz

2. Press “ | ” side of the Power Switch.

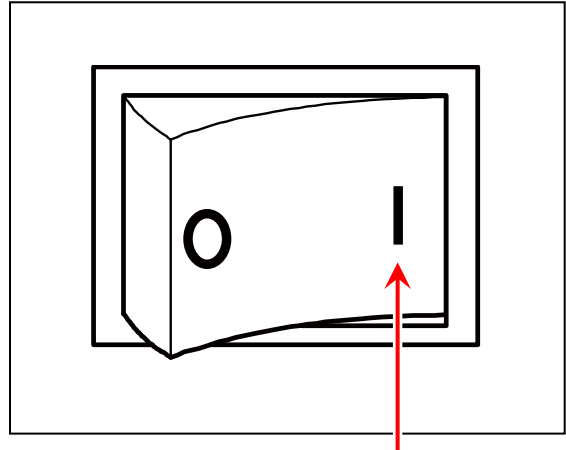

Press this side

3. The status indicator on the upper right of the printer is blinking and the warming-up is started.

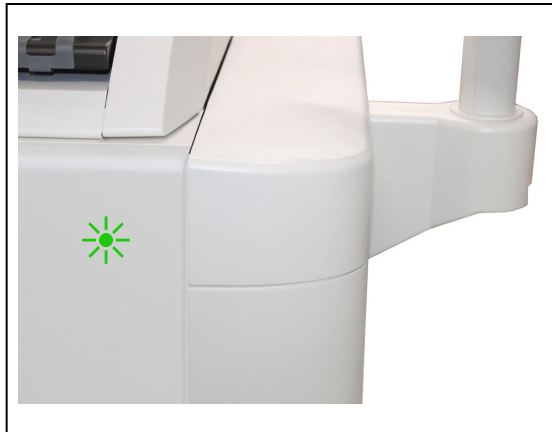

NOTE

The machine does not operate at all if the circuit breaker is turned off.
Flip up the circuit breaker switch to turn on the power supply.

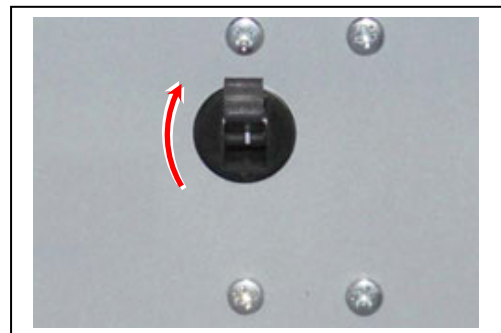

- The Printer will get ready about 6 minutes after turning on.
The Status Indicator stops blinking and lights green when ready.
Make a copy or print from outer devices.

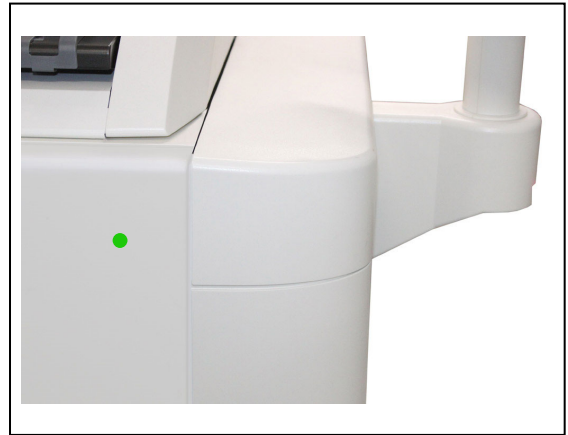
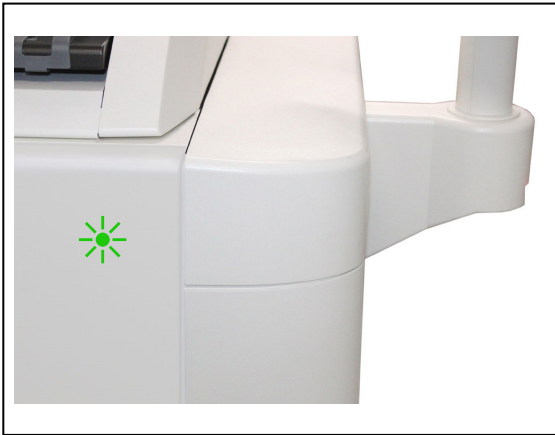

2. 2 Turning off the Printer

1. Press “O” side of the Power Switch.

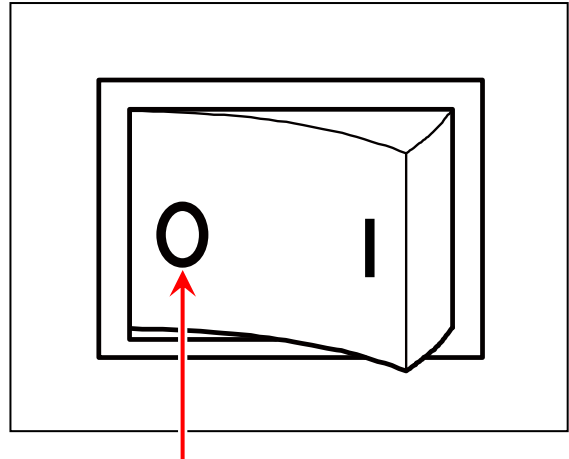

Press this side

2. The Status Indicator light purple while the embedded controller unit is shutting down. It will turn off in few minutes.



NOTE

The controller unit starts shutdown process after turning off the Printer, and it will take about 1 minute until complete shut down. Do not unplug the Printer from the outlet for about 1 minute after turning off therefore. The controller unit may be broken if the Printer is unplugged before the completion of shut down process.



3. If you completely shut the power supply due to a long vacation or the machine's transport, turn off the circuit breaker and then remove the power cable from the machine.



2.3 Replacing Roll Media

UI displays a sign of “Roll Replacement” when the used roll media gets empty. Follow the later procedure to load a new roll media.

1. Open the Roll Deck (1) that has empty roll media.
With catching the Flanges (2) on both sides, lift and remove the core of roll (3).

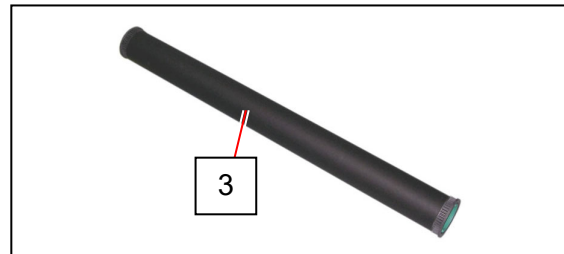
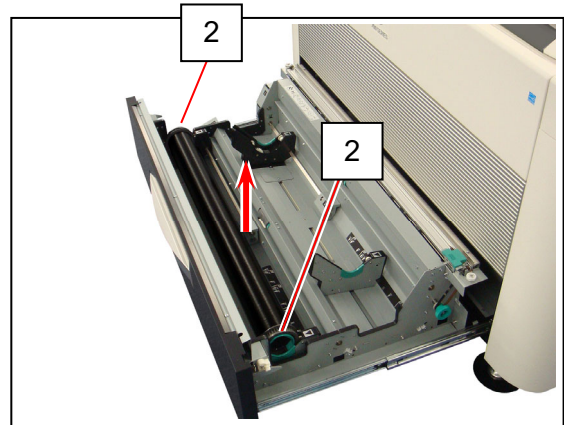
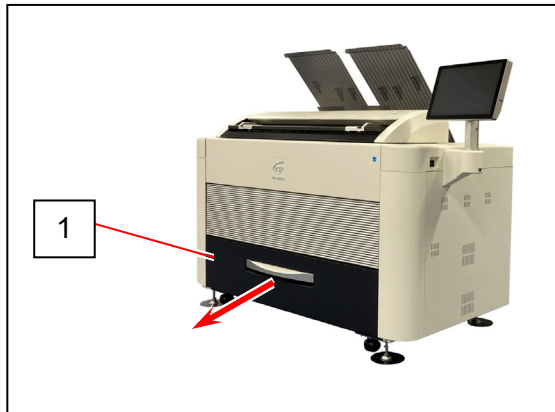

Reference

When a roll paper, without terminated by tape fixing to its core, is set to Roll 1 and has an event of roll empty, the remaining last portion of the sheet from the roll would stay in the Roll Deck as shown in the following picture. This is as engineered. Please remove the portion and then replace the roll media.

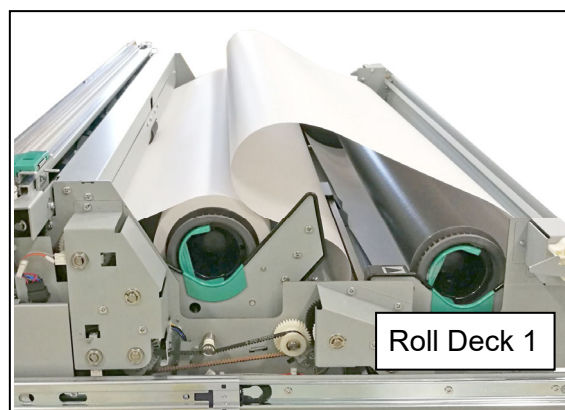

2. Pull the green lever (4) on each Flange (2), which releases the core of roll (3). Remove both Flanges (2).

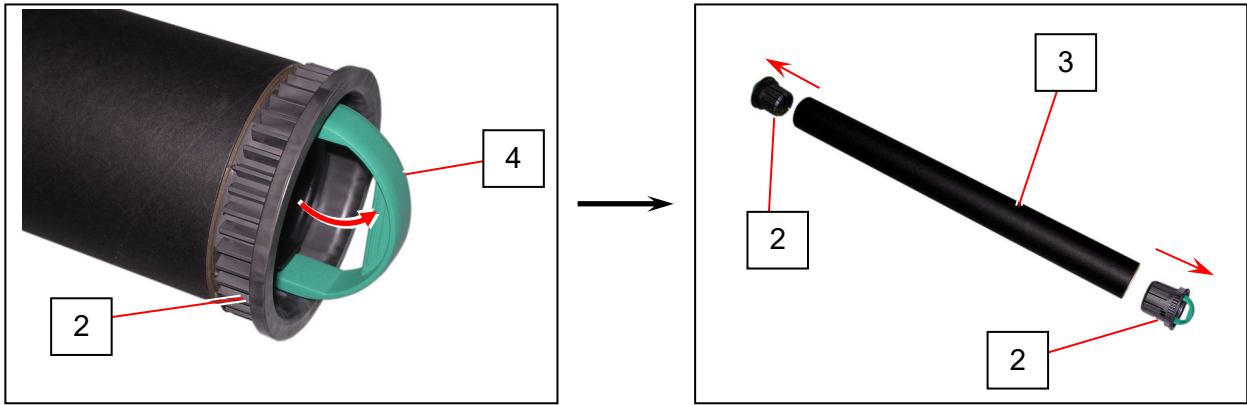

3. With sliding the Slide Guides (5) left and right by hand, align them to the width guide lines that match the width of actual media to be loaded. (Sliding either left or right one of 2 Side Guides also moves the other one by the same amount.)

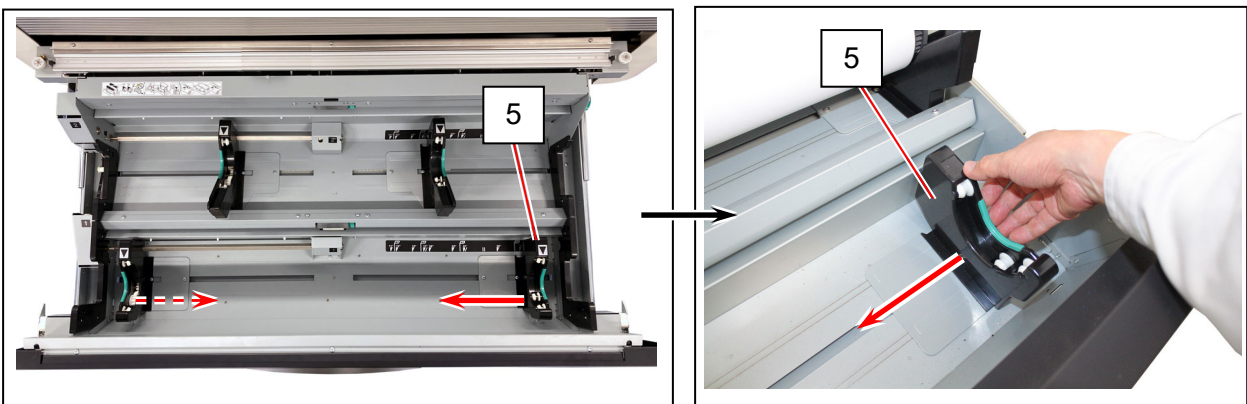

4. Insert both Flanges (2) deep into the core of new roll media until they stop.

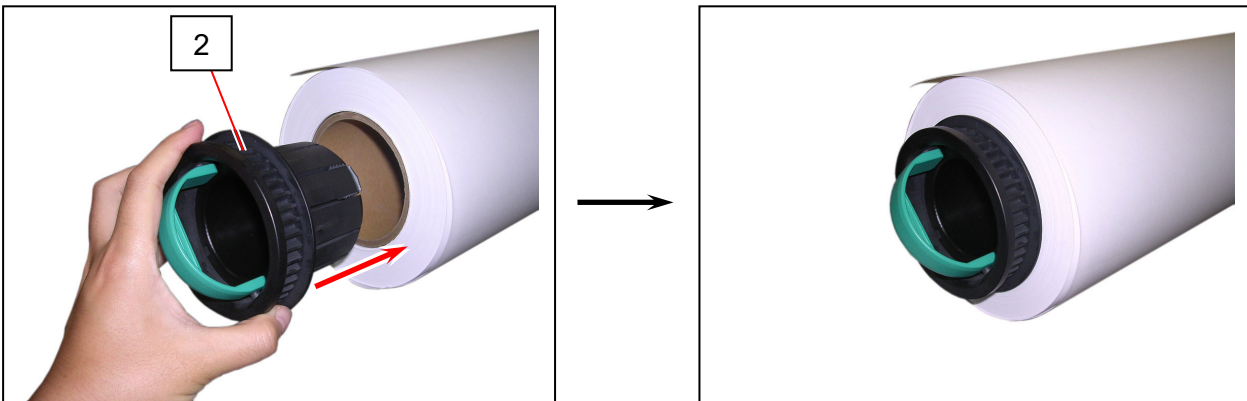

(See next page for more explanation)

NOTE

(1) Insert Flanges (2) deep enough into the core of roll media until their inside rims surely touch the side face of roll media with having no gap.

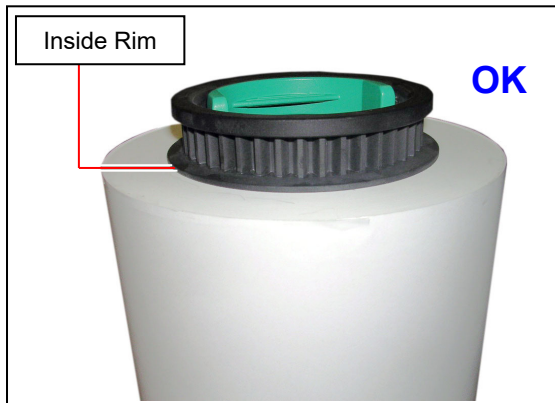

Correct: Fully inserted

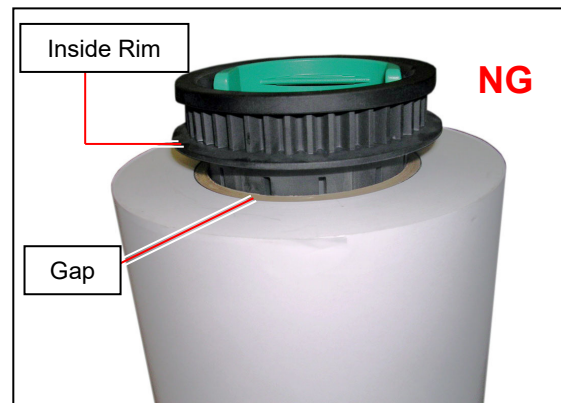

Incorrect: There is gap

(2) Be careful not to be harmed by the saw-toothed edge (6) when handling the Flanges (2).

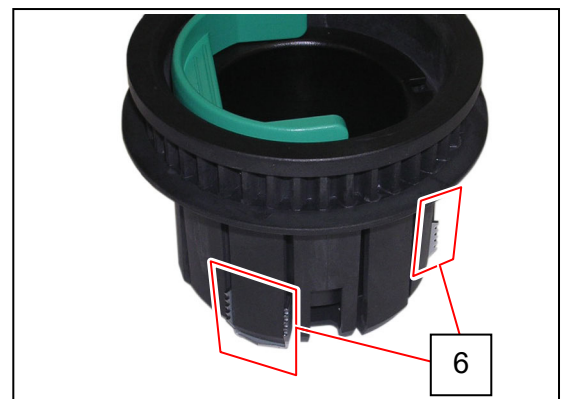

5. Turn down the lever (4) in either way until they completely stop, which lets the Flange to surely hold the roll media.

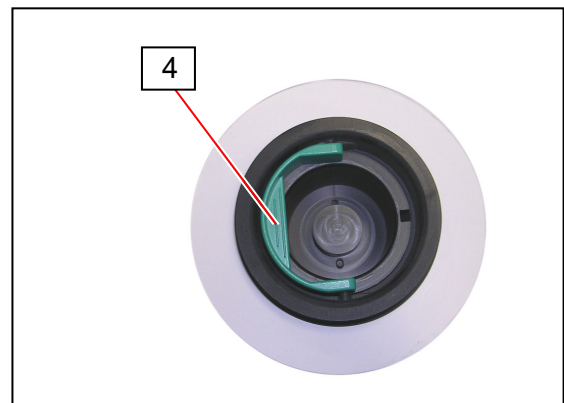
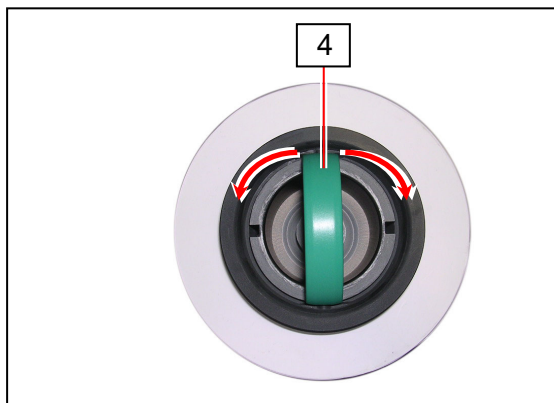

6. Fit both Flanges correctly into both Slide Guides (5) in the roll deck.

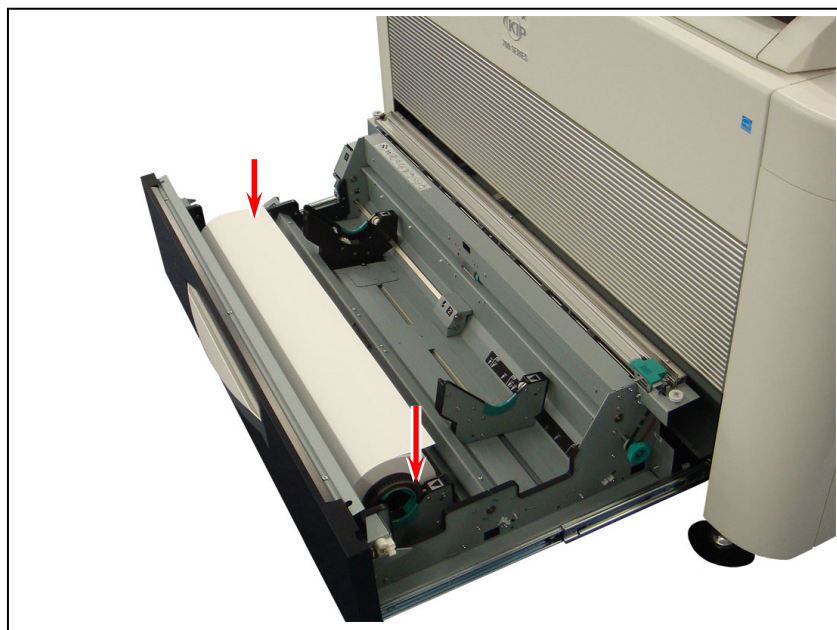
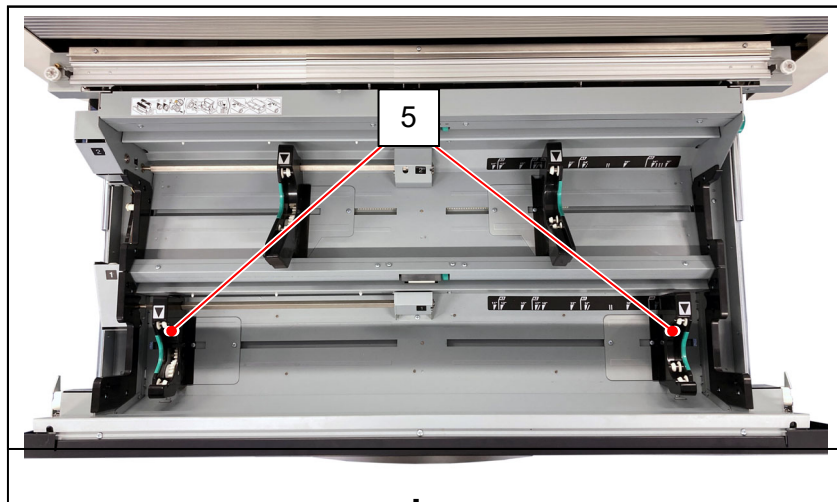

(See next page for more explanation)

! NOTE

(1) Note the position of leading edge. It should be on the top side when directed to the media feeding path.

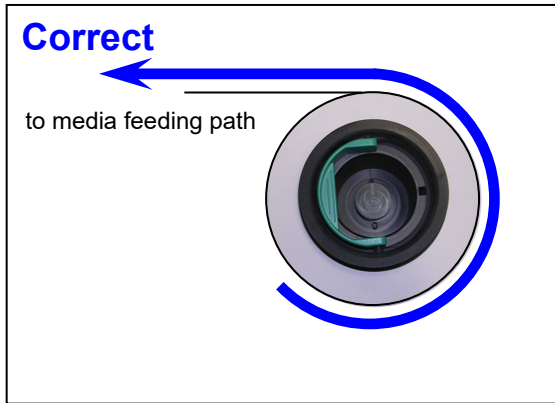

Correct : Leading edge is on top side

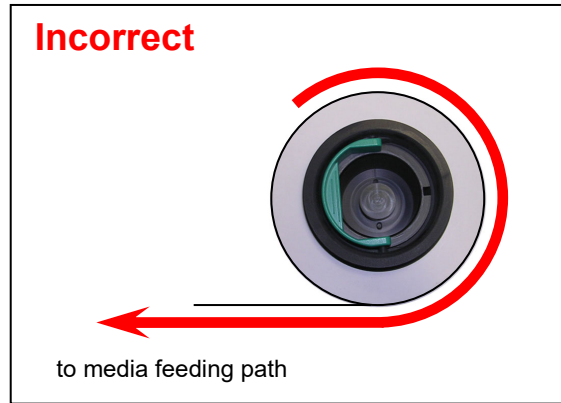

Incorrect : Leading edge is on bottom side

(2) The outside rim (7) of the Flange must be aligned with the tip of black triangle (8) for correct gear engagement. If not, the Flange may come off from correct position and may result in incorrect media feeding.

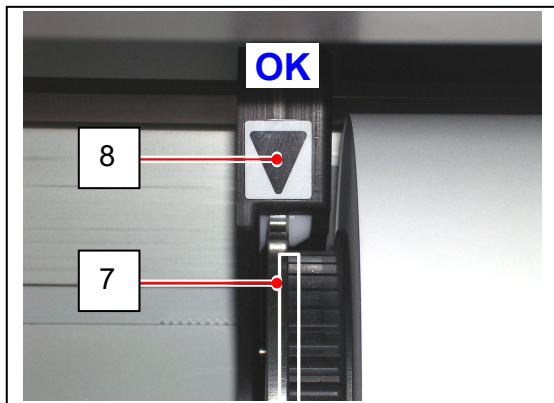

Correct

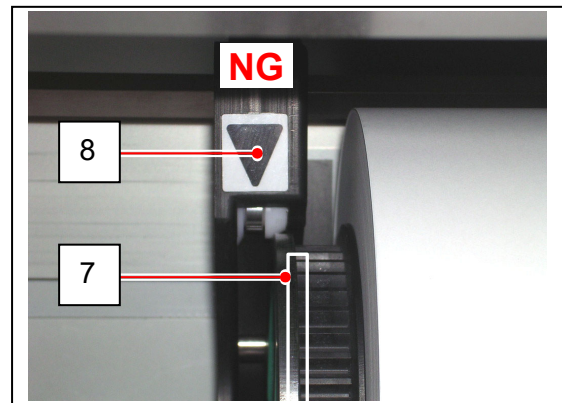

Wrong

7. Insert the leading edge under the corresponding Feed Roller (10), and then turn the Feed Knob (11) to forward the roll media.

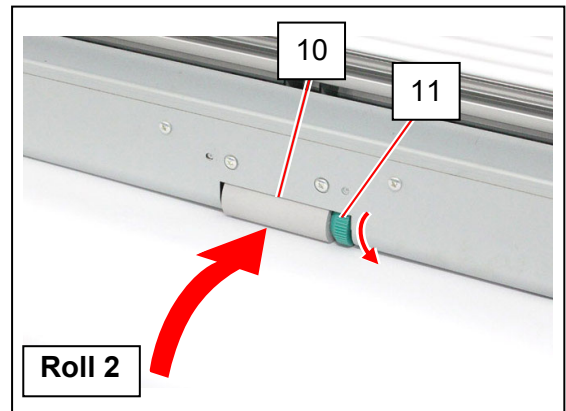
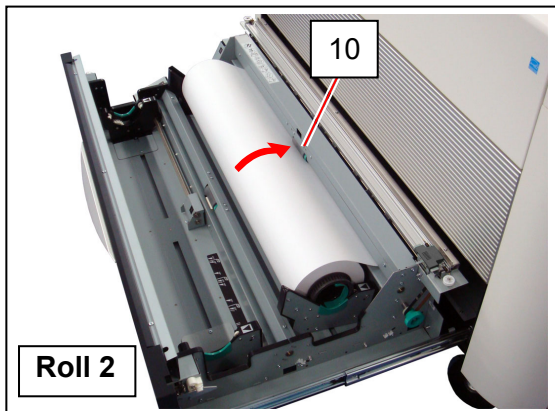
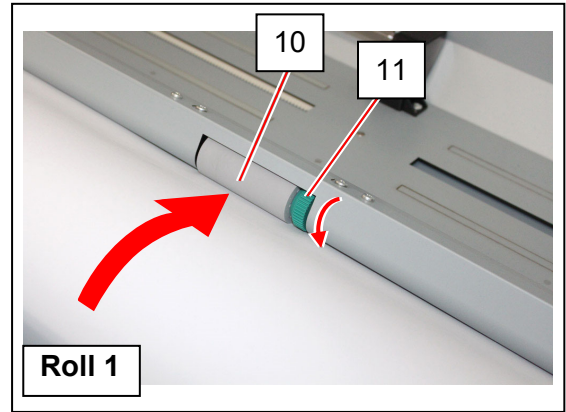
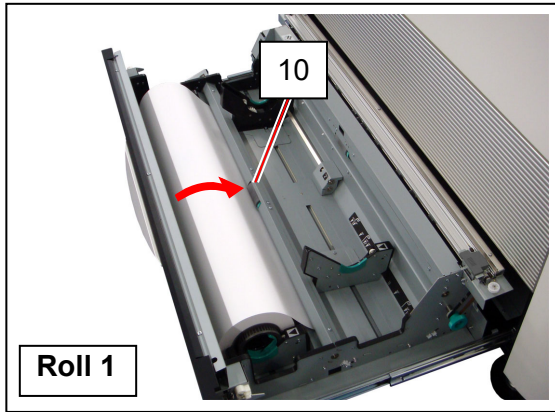

Reference

It is recommended to trim the leading edge of the new roll media after installing the roll media. There are two methods of the trim cut, Auto and Manual.

Auto:

Trim button is available in the UI to take the trim cut automatically. Go to the next step 8.

Manual:

Operators can use the cutter unit to manually cut the roll media. Please see the following instruction.

1. Insert the leading edge under the corresponding Feed Roller (10), and then turn the Feed Knob (11) to forward the roll media. Keep forwarding the roll media until it stops by its leading edge blocked by the next feeding roller.

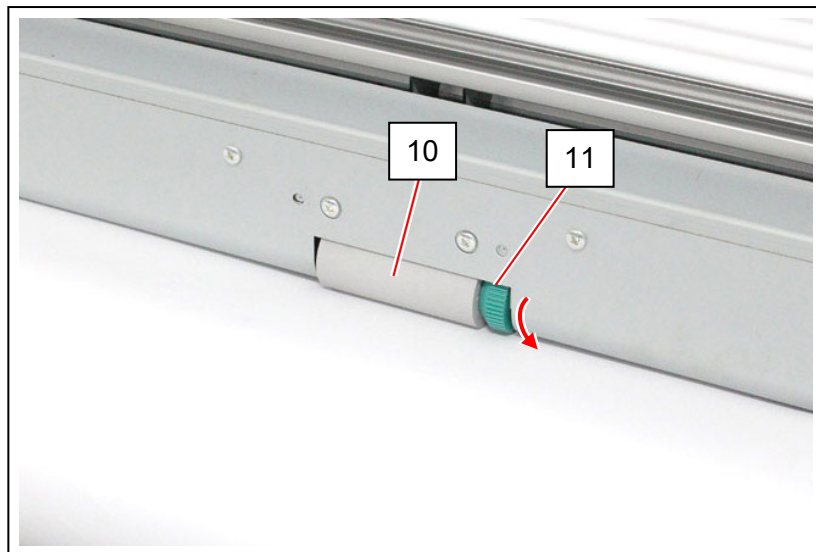

2. If you rotate the Feed Knob (12) in the direction of arrow, the media is forwarded and comes out from the slit on the rear side of the Roll Deck. Keep forwarding the media until the leading edge comes out by about 100mm.

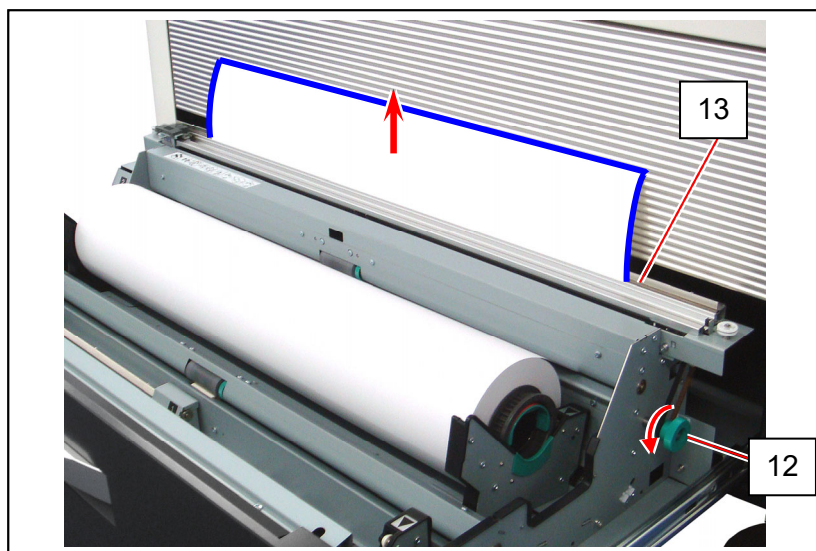

(See also next page)

Reference

- Slide the green Tab (14) from one end to the other end at a time. The leading edge section that is coming out from the slit is cut off, and this straightens the leading edge of the roll media. Remove the cut portion.

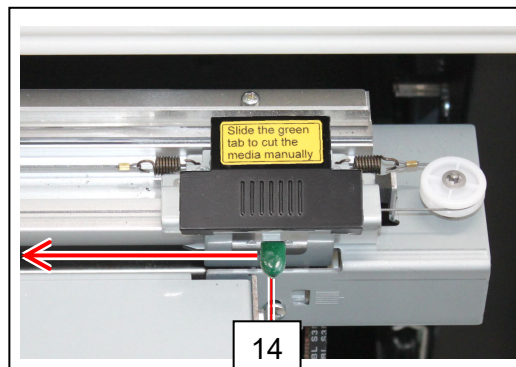
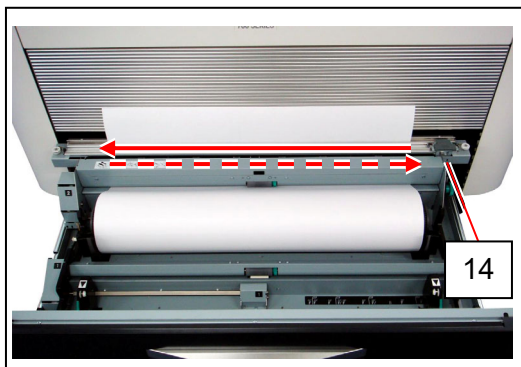

! NOTE

Please surely follow below instructions when sliding the green Tab. Incorrect operation will lead you to the damage to the Cutter Unit.

- When you slide the green Tab to the right or left to cut the media, please do not pull it to the front because it will cause to damage the cutter unit.
- Please hold only the green Tab when sliding the cutter. Please do not hold any other part as it can cause to damage the Cutter Unit.



8. Push the Roll Deck (1) back in.

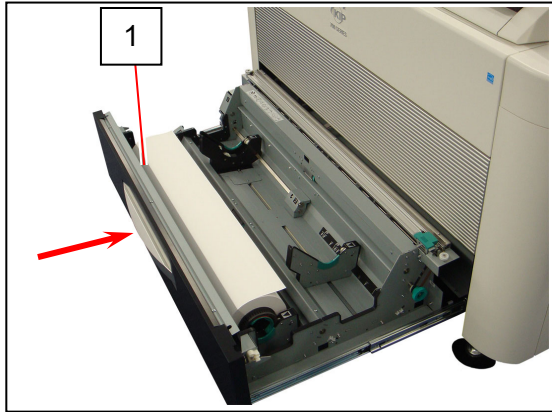

⚠ NOTE

- (1) Surely close the Roll Deck until it is locked. A paper jam may occur if not locked perfectly.
- (2) Be careful not to catch your finger in between Roll Deck drawers.

9. Define the media information (media type and width) with using the touch screen. If necessary, press the Trim Button  (Scissors icon) or [Trim all] button. Press [OK].



NOTE

- (1) Please set correct type and width settings. Incorrect settings would lead unexpected print results.
- (2) If no roll media is installed in the Roll Deck at all, the printer status does not get "Ready" and the touch screen shows "Attention Required". Follow the instruction in this section to set a roll media properly, and the status will get "Ready". If still "Attention Required" remains, contact your local service representative.

Reference

The printer will take a programmed internal cleaning process when a roll media is switched to another. Please wait until the cleaning finishes and the status gets "Ready".

2.4 Trim Cut

Trim Cut is to straighten the leading edge of an installed roll media. It is recommended to make trim cut in the following situations.

- After installing a new roll media to the printer
- After having a paper jam and in case the leading edge of a roll media is torn or folded

There are two methods to make trim cut, Auto and Manual.

2.4.1 Auto Cut

1. Press the Media area in the Home screen.

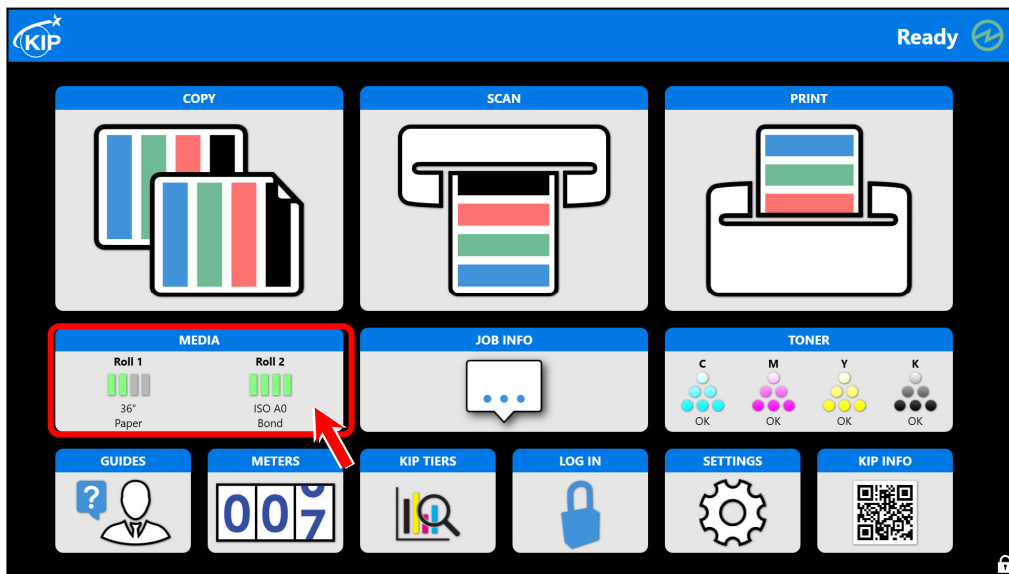

2. Press the Trim Button  to make trim cut on your desired Roll Deck. [Trim all] Button is to make trim cut on all available Roll Decks.

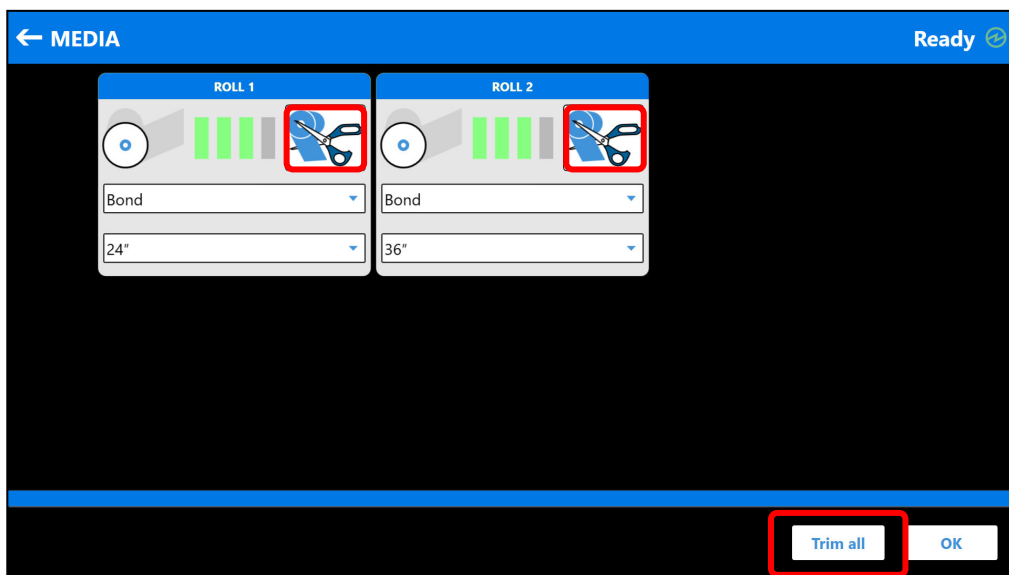

2.4.2 Manual Cut

1. Open the Roll Deck (1).

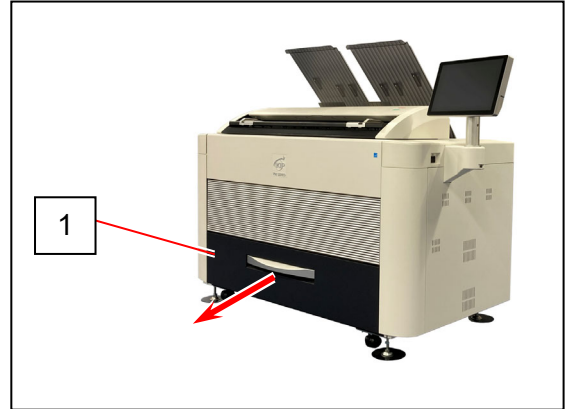

2. Feed the Knob (2) to forward the roll media. Keep forwarding the roll media until it stops by its leading edge blocked by the next feeding roller.

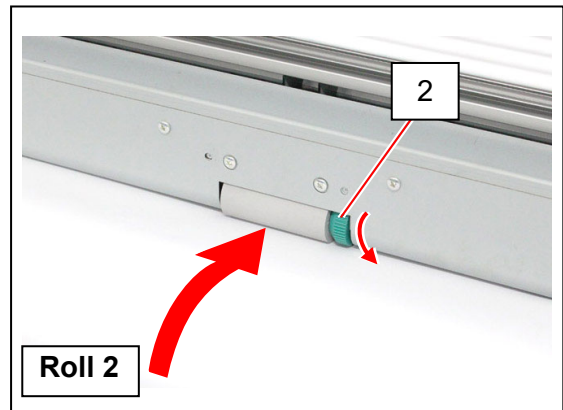
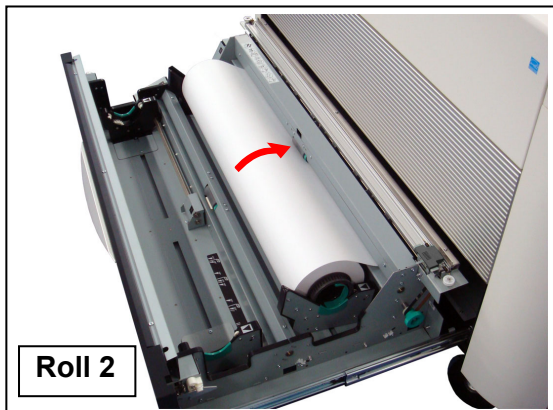
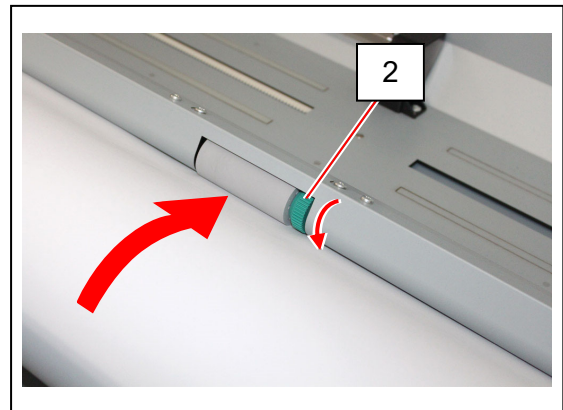
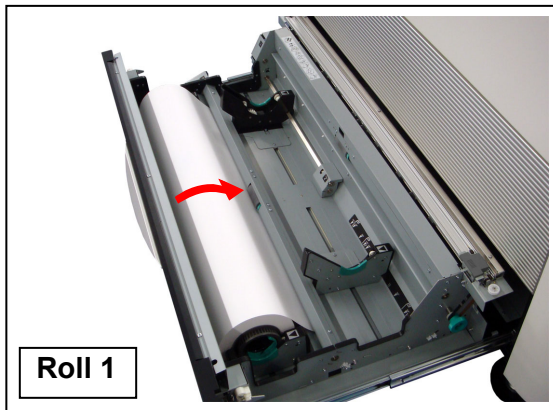

3. Rotate the Feed Knob (3) in the direction of arrow, and the media is forwarded and comes out from the slit on the rear side of the Roll Deck. Keep forwarding the media until the leading edge comes out by about 100mm.

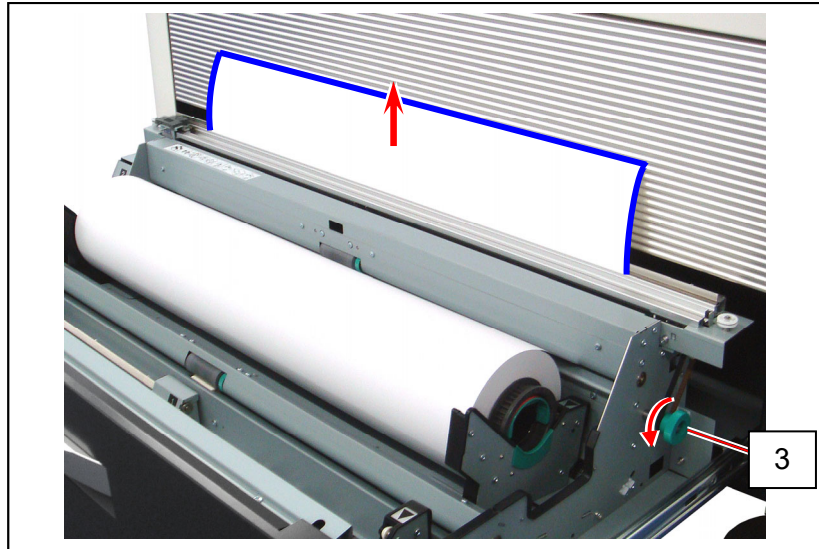

4. Slide the green Tab (4) from one end to the other end at a time. The leading edge section that is coming out from the slit is cut off, and this straightens the leading edge of the roll media. Remove the cut portion.

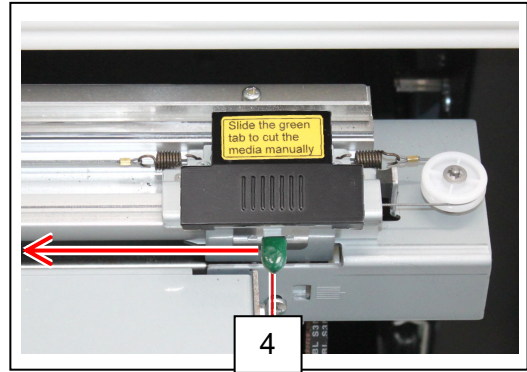
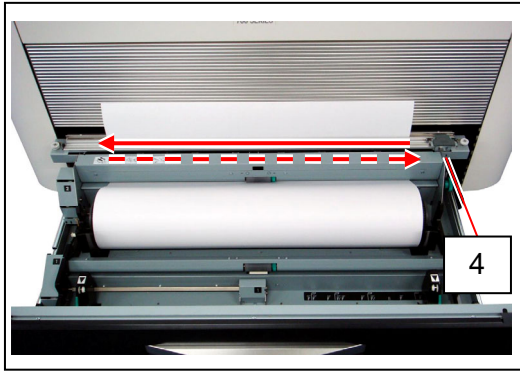

! NOTE

Please surely follow below instructions when sliding the green Tab (4). Incorrect operation will lead you to the damage to the Cutter Unit.

- (1) When you slide the green Tab to the right or left to cut the media, please do not pull it to the front because it will cause to damage the cutter unit.
- (2) Please hold only the green Tab when sliding the cutter. Please do not hold any other part as it can cause to damage the Cutter Unit.



5. Push the Roll Deck (1) back in.

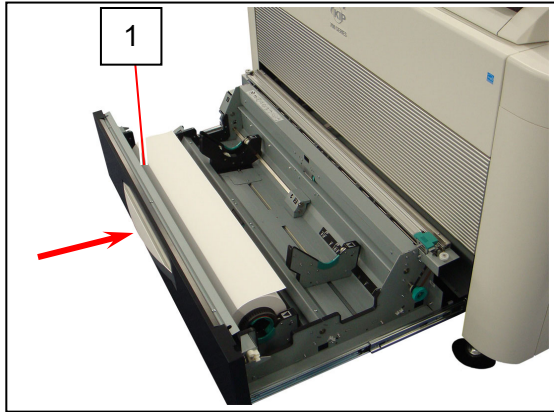

⚠ NOTE

- (1) Surely close the Roll Deck until it is locked. A paper jam may occur if not locked perfectly.
- (2) Be careful not to catch your finger in between Roll Deck drawers.

2.5 Toner Supply

Reference

When the toner is empty, the screen indicates “Replace Toner”.
Please add the requested genuine toner as instructed in the screen. The printer keeps waiting until the requested toner is added.

The replacement procedure is also included in the guide on the touch screen.

WARNING

There is combustible powder in the toner cartridge.

Do not burn up used toner cartridges.

1. Open the Toner Cover (1).

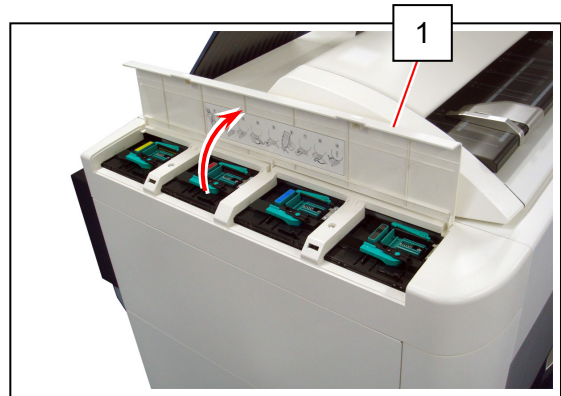

2. Gently shake a new Toner Bottle (2) well to loosen the powders inside the bottle.

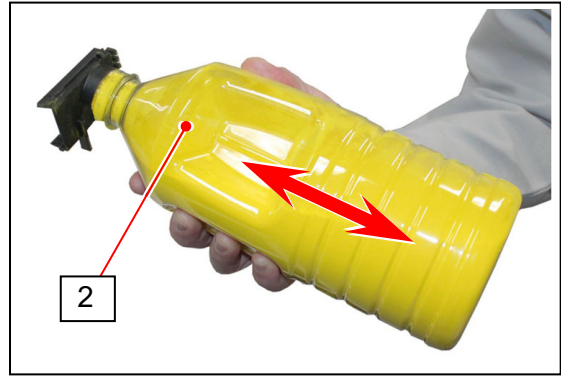

! NOTE

To make the toner powder smoothly leave from the Toner Bottle on the next step, please ensure the followings.

- After shaking the bottle, supply the toner to the machine without a pause.
- Do not shake the bottle sharply. Doing so may the toner powder get pressed and compacted.

3. Fit the supply hole on the Toner Bottle (3) with the set position of on the Toner Hopper (4). Once the supply hole on the Toner Bottle (3) fits the receipt on the machine side (4) correctly, the Lever will automatically catch the Toner Bottle as shown below.

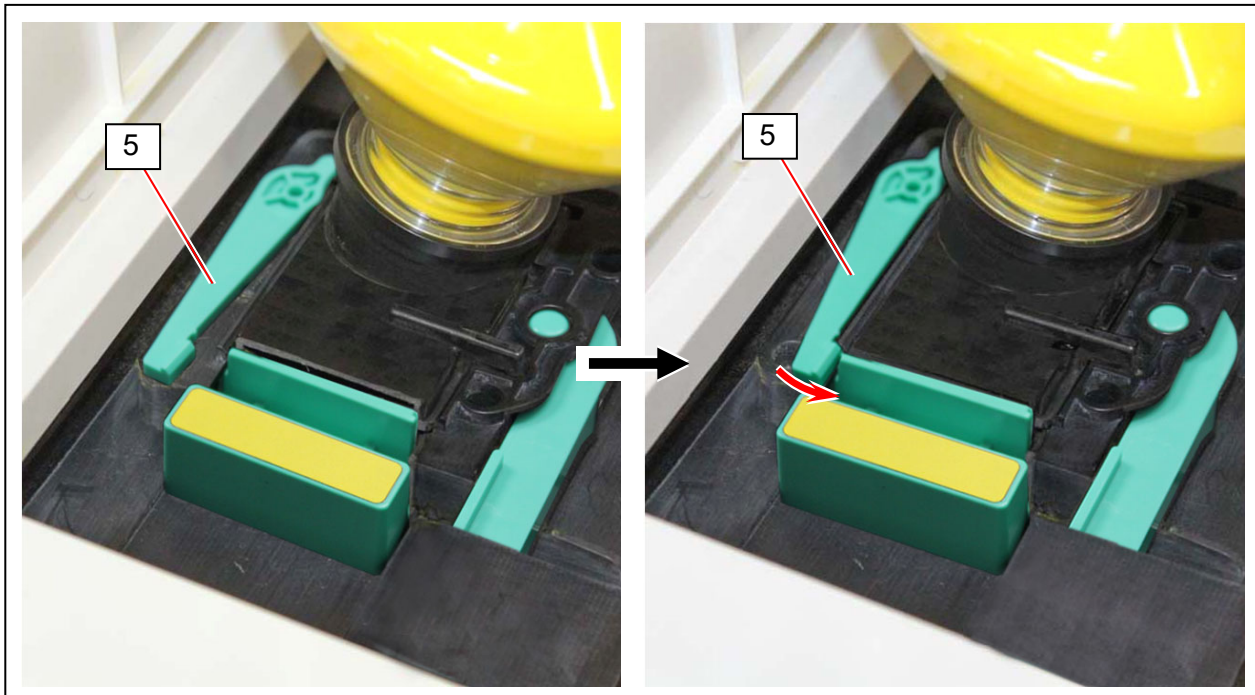
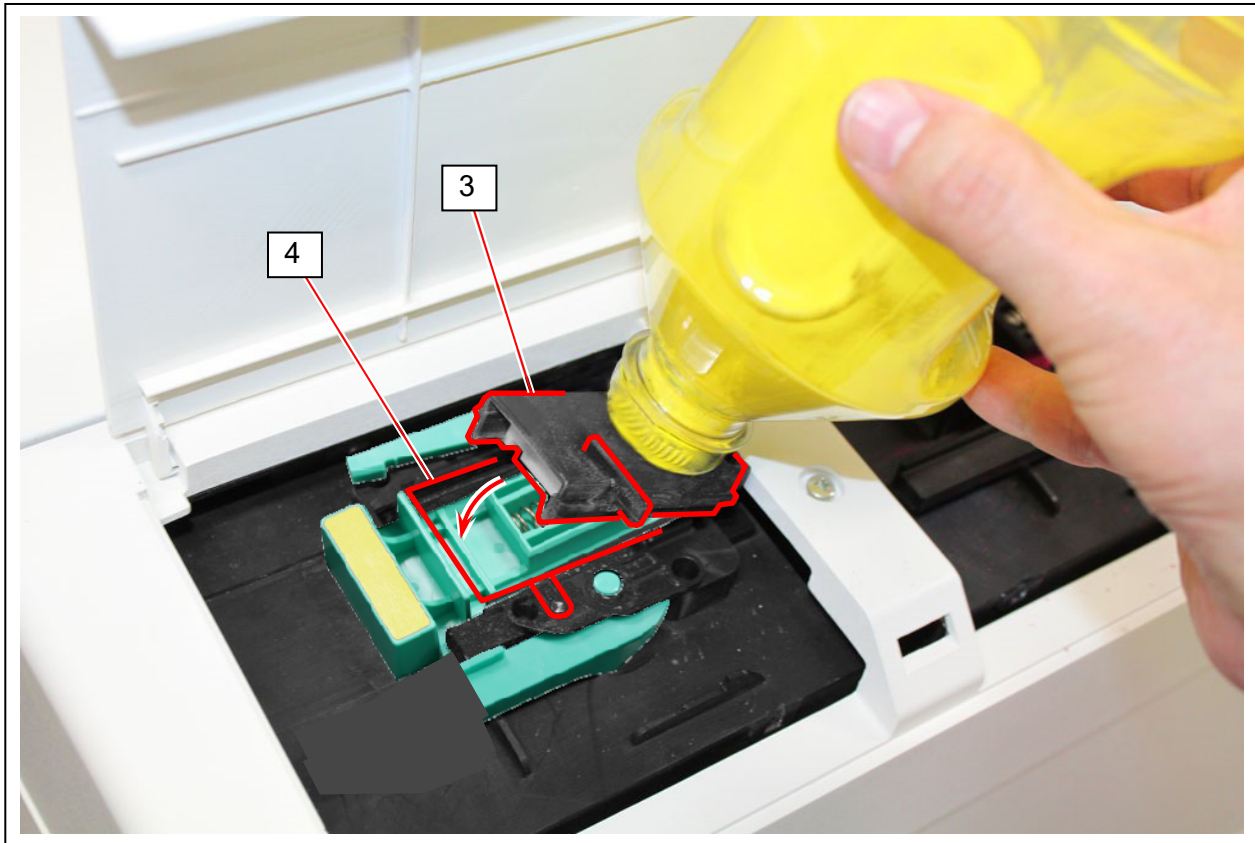

4. Fit the Toner Bottle so that the tab part (6) can push the pin (7).
Turn the Lever (8) to lock the Toner bottle with the Toner Hopper.

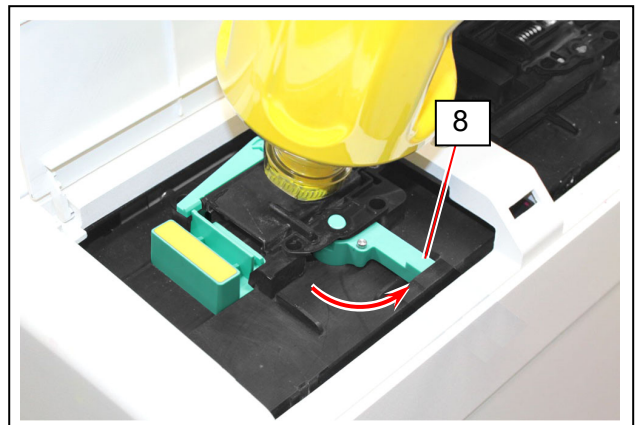
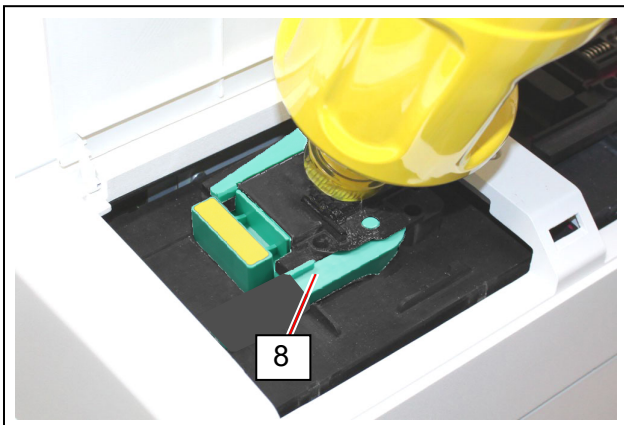
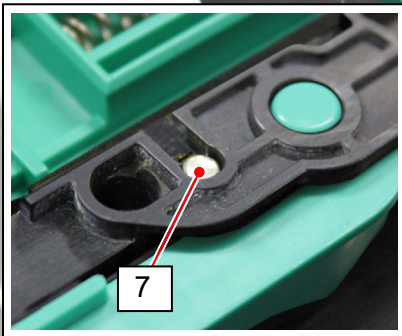
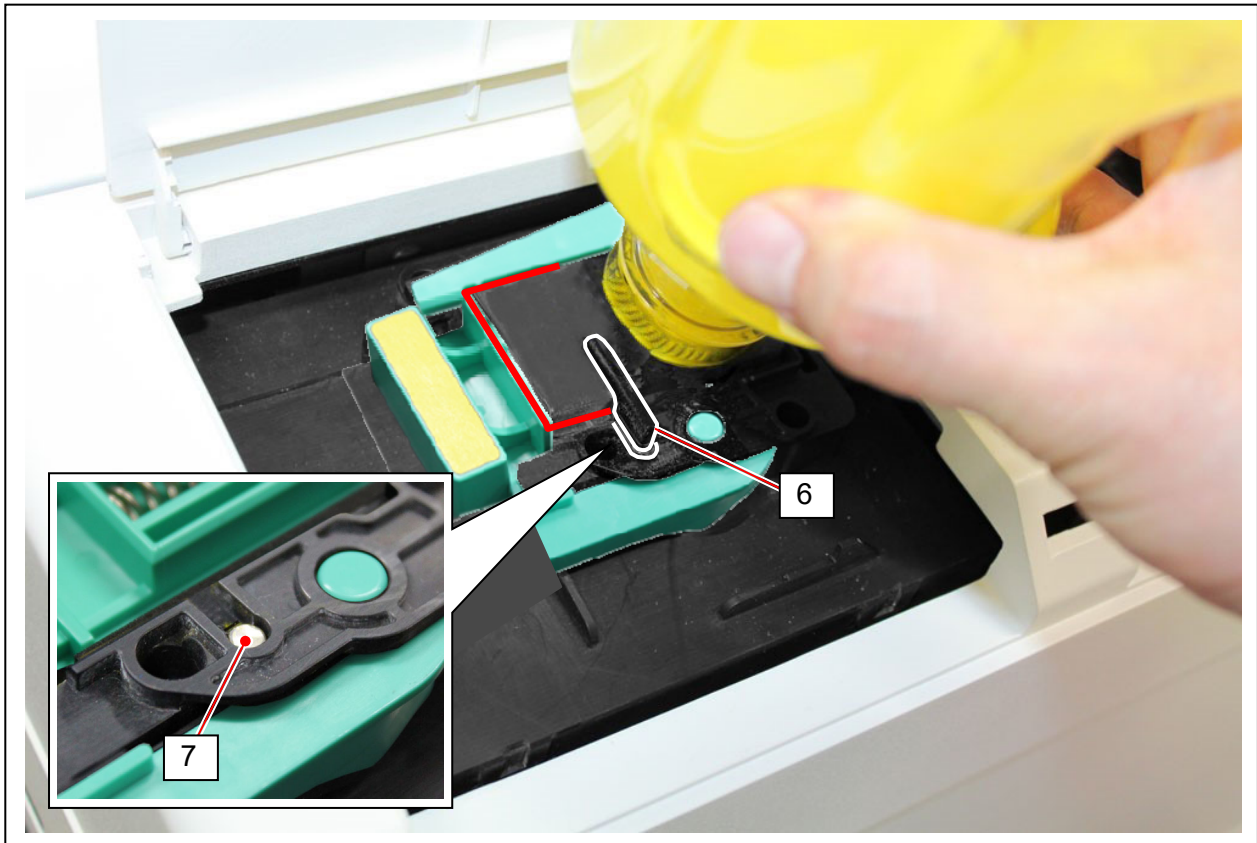

5. Move the Slide Lever (9) to the arrow direction. Now the toner powder inside the bottle falls in the Toner Hopper. After the most amounts of the toner falls, turn the Toner Bottle body 3 revolutions so that the retaining toner in the Toner bottle can fall.

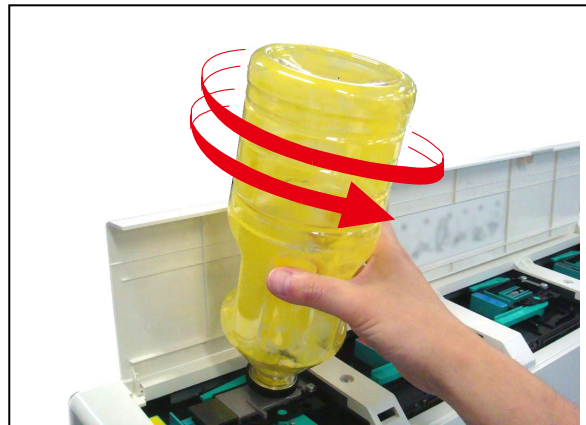
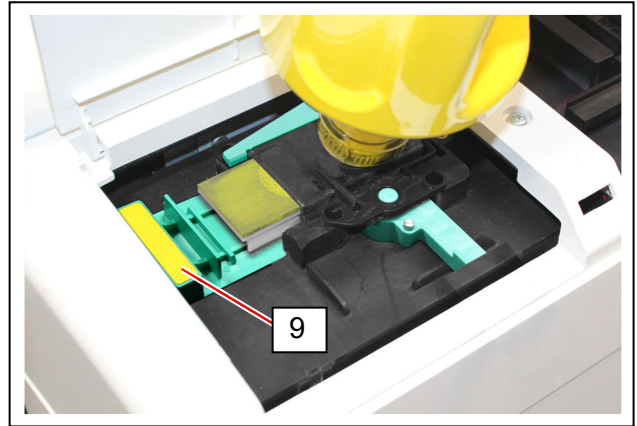
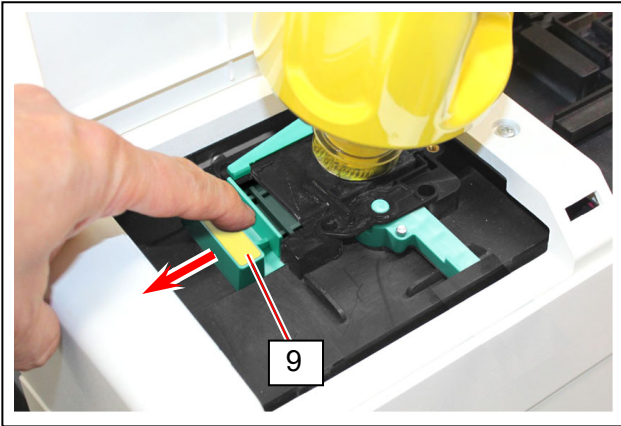

⚠ NOTE

To use up the toner powder left in the bottle, turn the bottle to either direction, by 3 revolutions. If you apply strong force to the bottle, the toner may spill out.

- Do not rap the Toner Bottle hard.
- Do not twist the Toner Bottle.
- Do not squash the Toner Bottle.

6. When the toner supply to the Toner Hopper is finished, move the slide lever (9) back until it stops at the line (A). (May feel slight resilience when the slide lever (9) reaches the end)

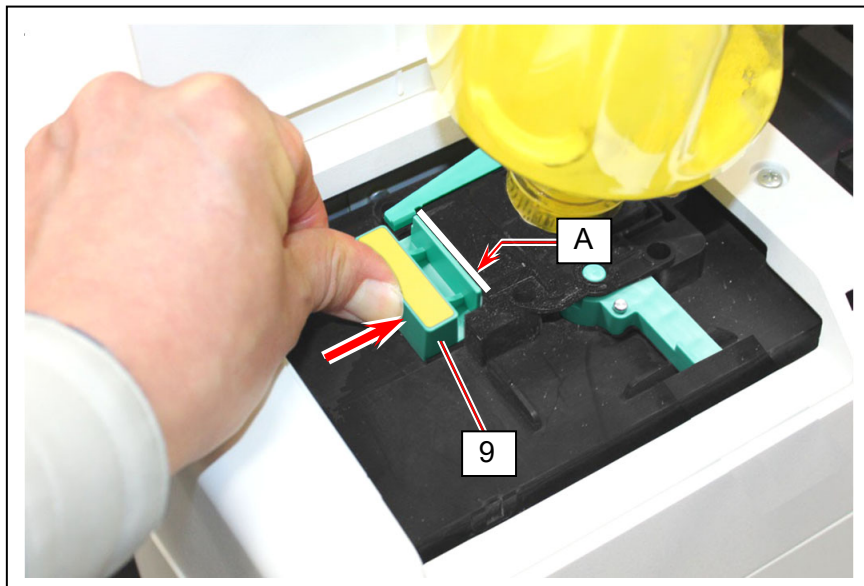

7. Turn the lever (8) to the original position.

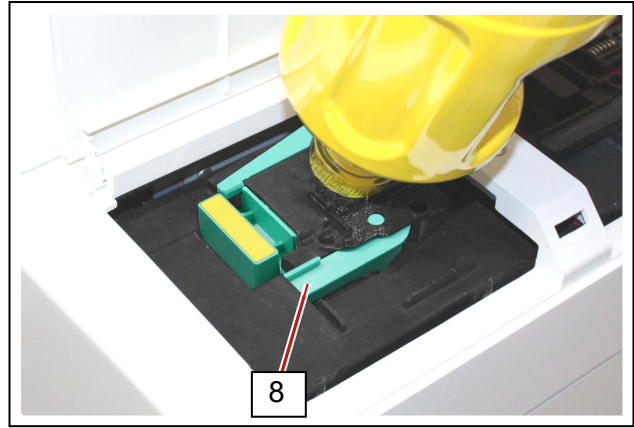
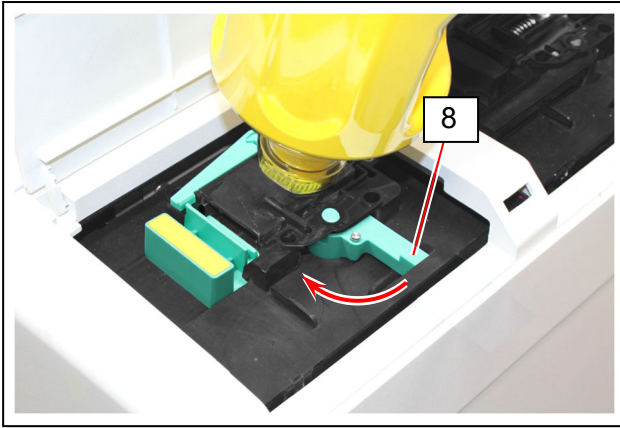

8. With pushing the release lever (9) to the direction of the arrow, detach the Toner Bottle.

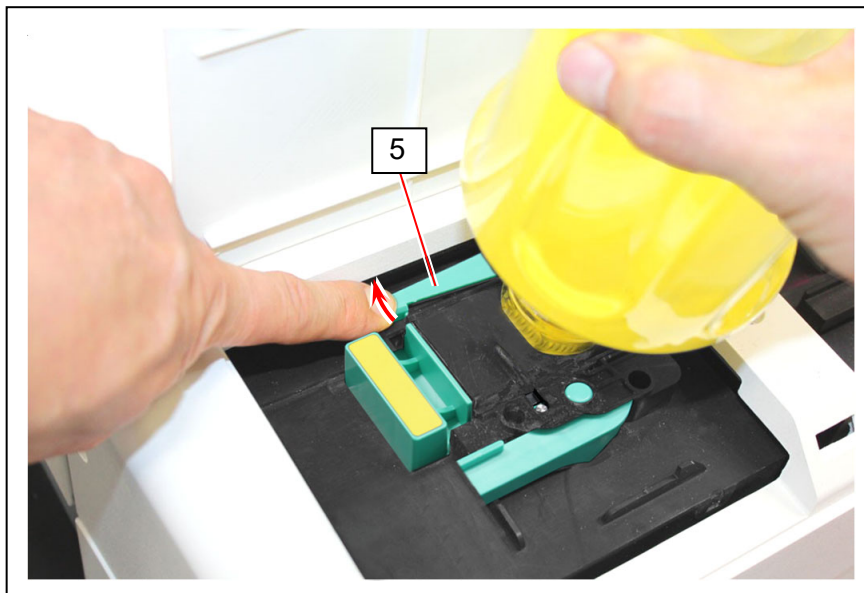

⚠ NOTE

The full capacity of the toner hopper is one toner bottle.
Do not supply the toner more than the above.

⚠ WARNING

There is combustible powder in the toner cartridge.
Do not burn up the used toner cartridge.

9. Press the Toner Recovery button in the touch UI. The printer will properly supply the toner to the imaging section and takes necessary toner refilling actions automatically.

- The printer goes into “warm up” while processing toner supply. Please wait until the supply is completed.
- The printer gets “ready” after the toner refilling completes.

2. 6 Replacing Toner Receptacle

When the Toner Receptacle is full, the UI screen shows “Cartridge Full.”
The printer does not restart operations until the Toner Receptacle is properly replaced.



1. Assemble the Toner Receptacle Box as follows.

Reference

(1) It is easier to assemble by pre-folding beforehand on the fold lines.

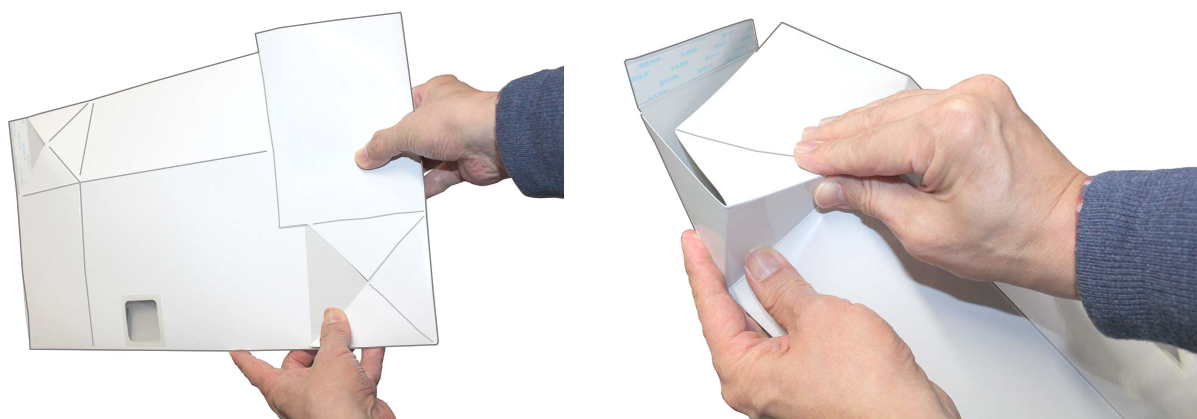

(2) It is easier to assemble by starting to fold from the side with the toner dropping port.



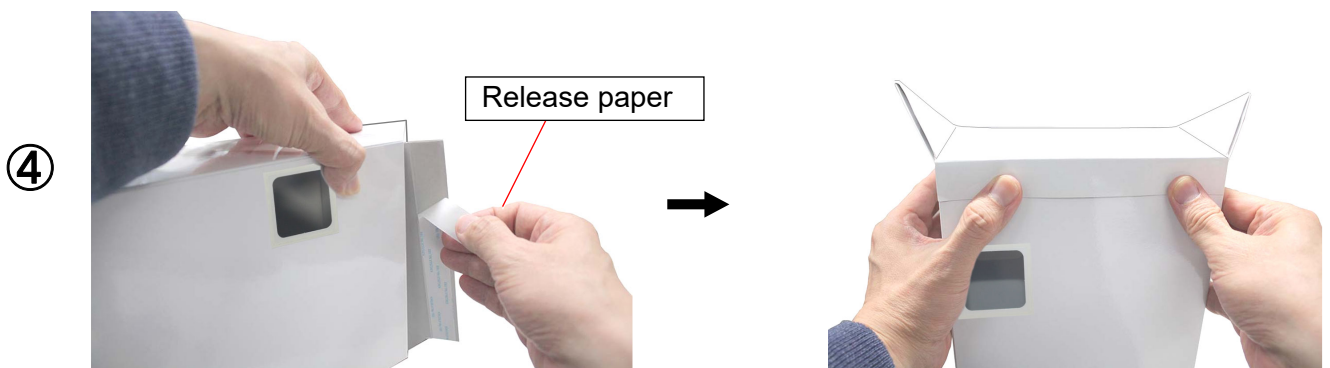
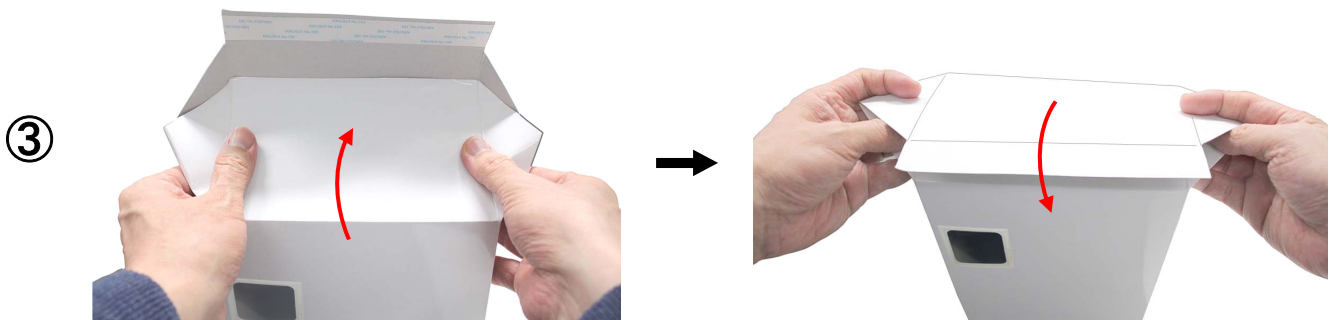
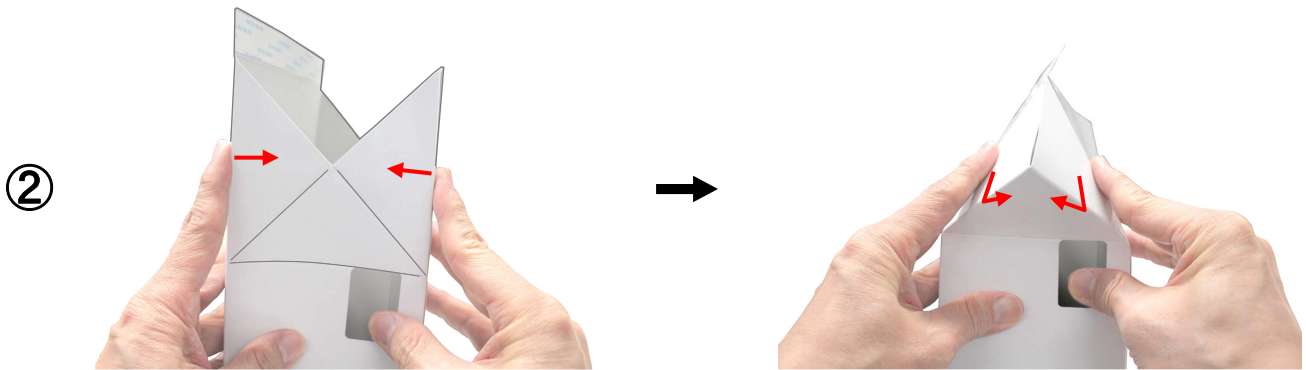
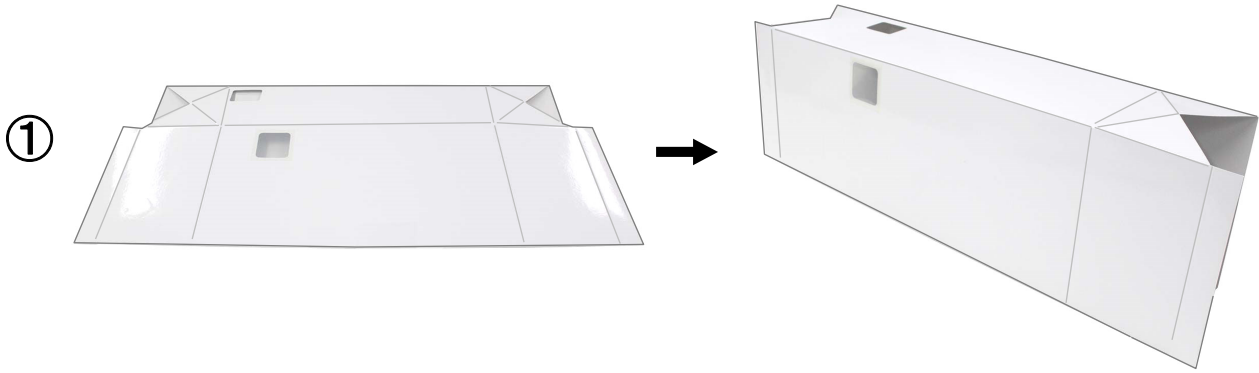

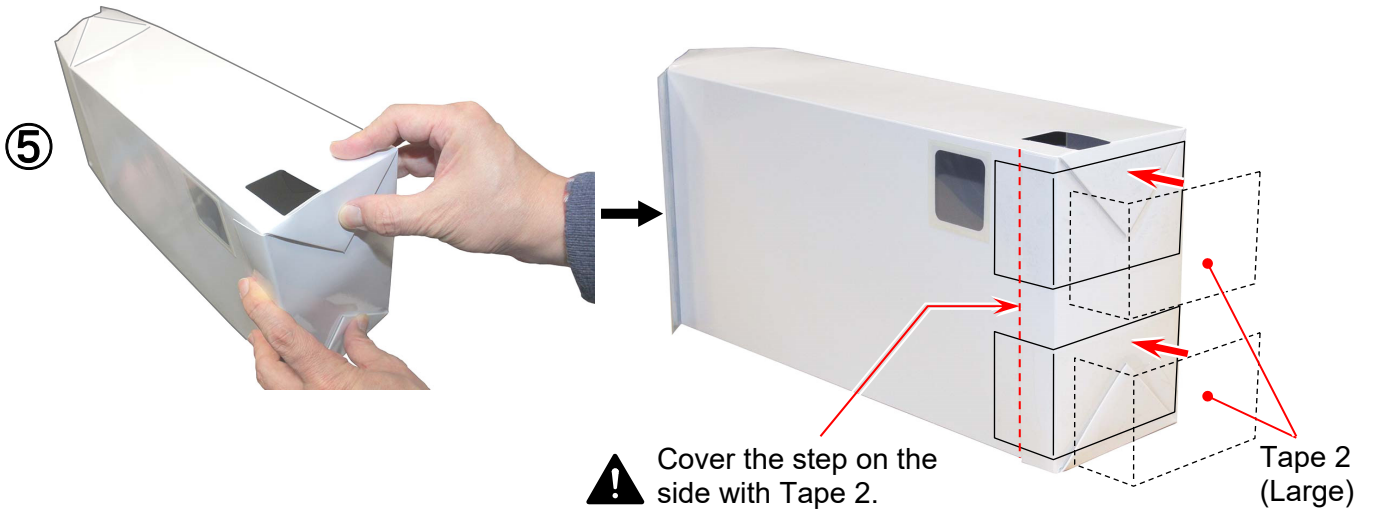

! NOTE

Apply the Tape 2 in L-shape to cover the step on the side. Otherwise the step might get caught by the toner receptacle shutter part to prevent from smooth removal of the box.

⑥ Assemble the other side in the same way (Step 2 to Step 5).

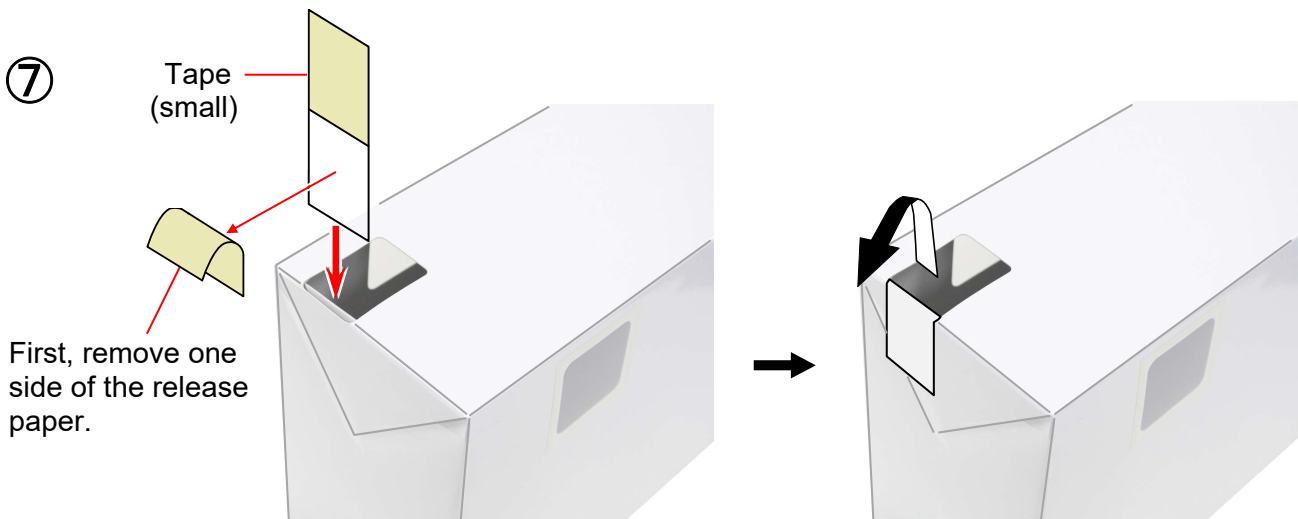
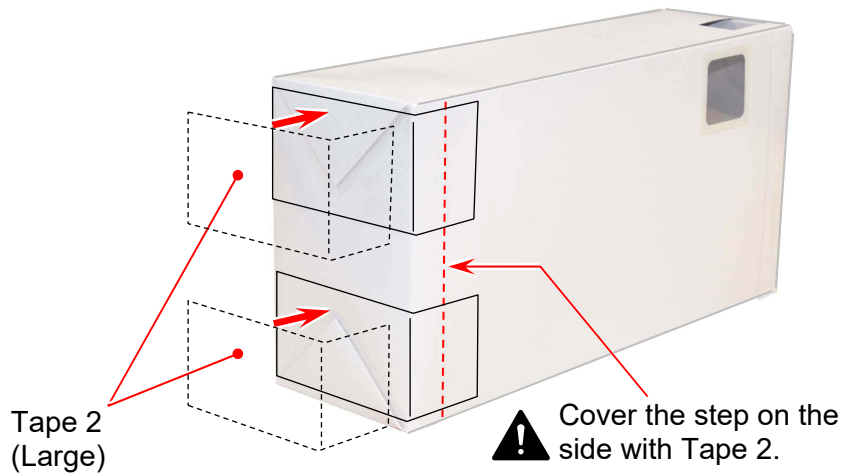

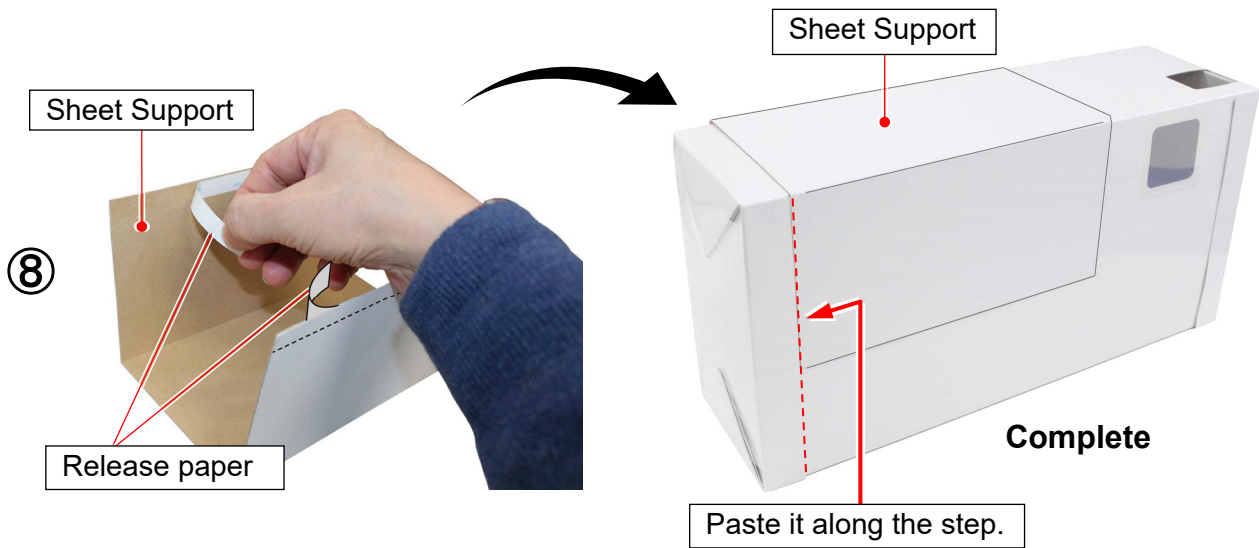

2. Open the Left Side Cover (1).

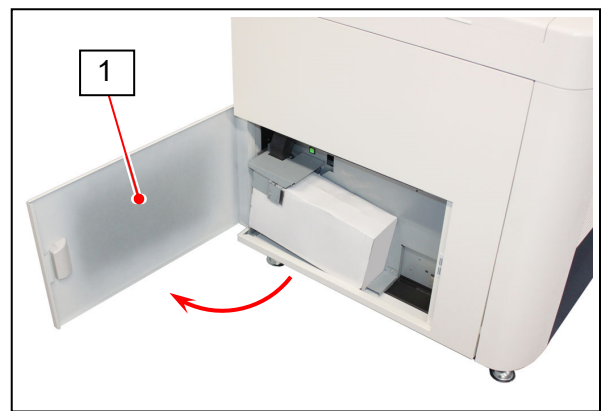

3. With holding the Toner Receptacle Box (2) with your hands, bring it up and move it frontward to remove from the machine.

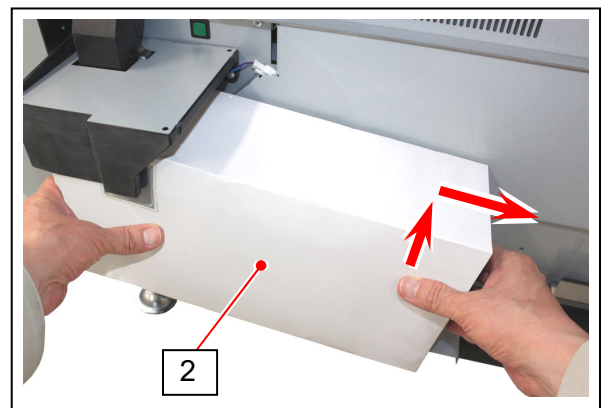

4. Apply the Tape 2 (Large) (3) to close the opening of the Toner Receptacle Box, which is included in the Toner Receptacle Box Kit.

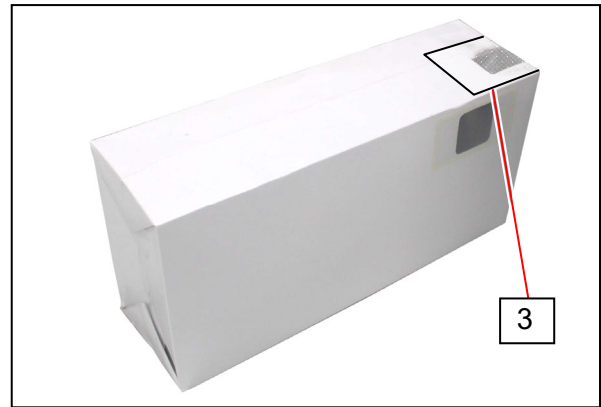

⚠ WARNING

The toner will explode if thrown into a fire.

⚠ NOTE

- (1) Do not handle the Toner Receptacle Box roughly. Otherwise, the toner will come out from its open hole.
- (2) The Toner Receptacle Box should be discarded according to your local regulations.

5. Set the new Toner Receptacle Box (4) back in the original position. See the following NOTE.

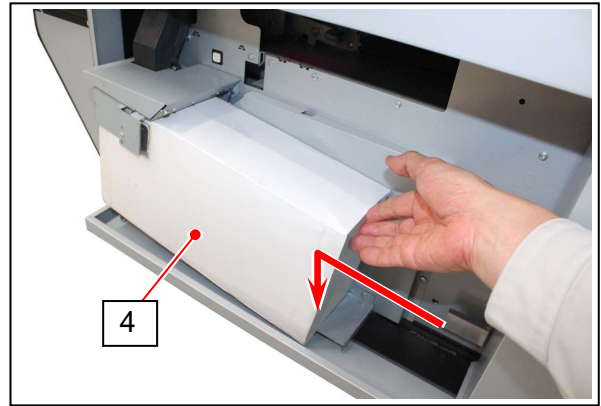

NOTE

(1) Place the bottom corner of the box at the inside of the positioning step (5).

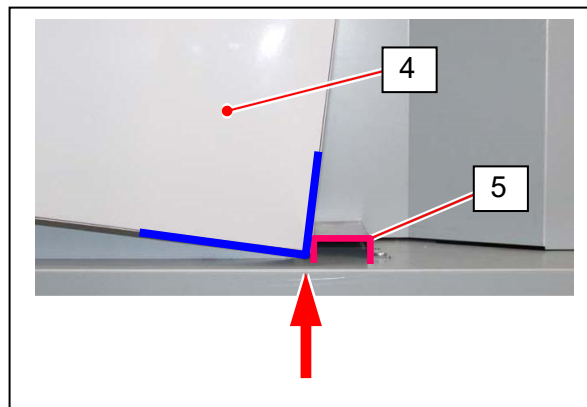

(2) Make sure the clear film windows (6) is not dirty.

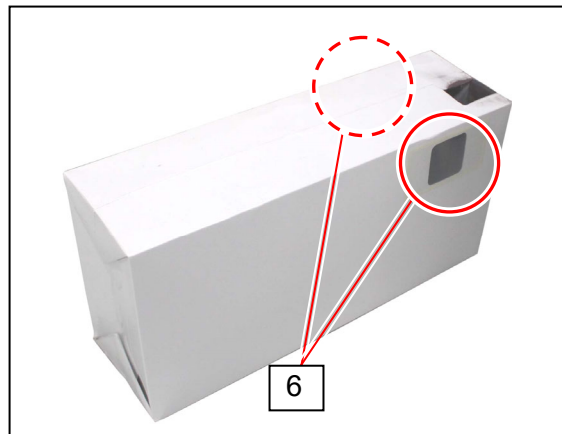

6. Close the Left Side Cover (1).

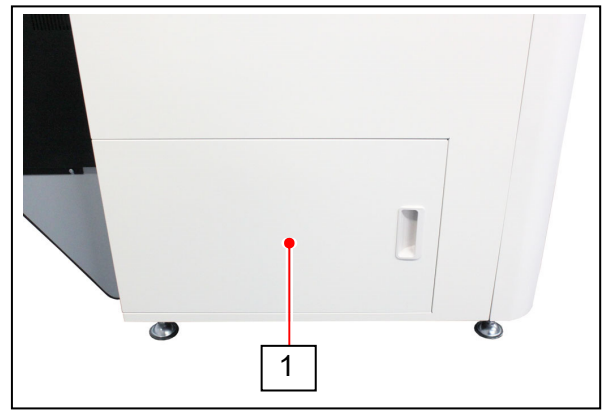

7. Press "Reset" displayed in the UI screen to allow the system to check the new Toner Receptacle.

2.7 Attaching the Tray C (Asian model only)

Tray C is to help correct stacking of the pages printed using tracing paper and film, which can be placed into position or removed optionally by the operator. Please fit it to its position when printing using tracing paper or film. And please do not use it when printing using the plan paper.

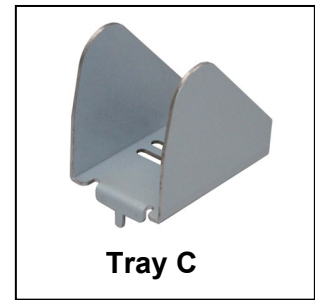

1. Remove the Exit Tray 2 (1).

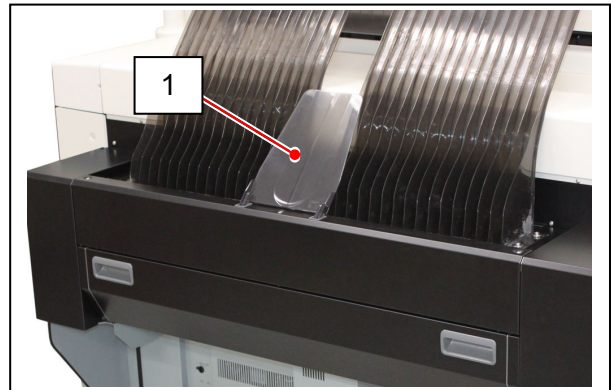

2. Each Tray C (2) has a “step” (3). Insert the step (3) into the 5th slit on the Fuser Top Cover, which is the 5th one when seen from the rear side.

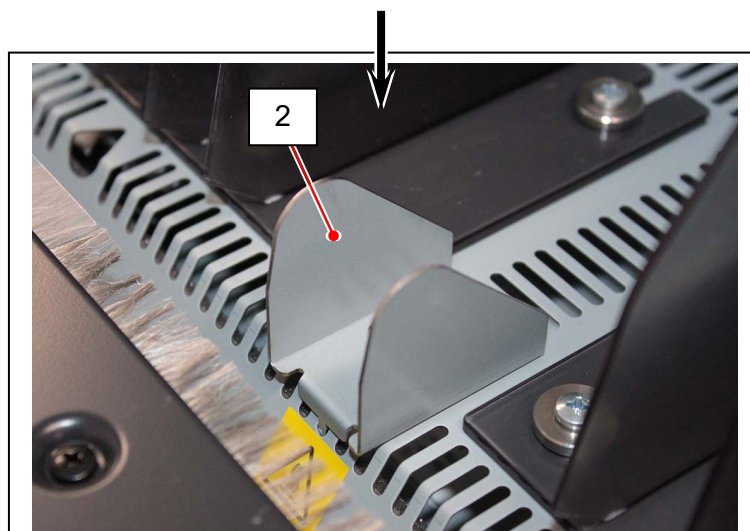
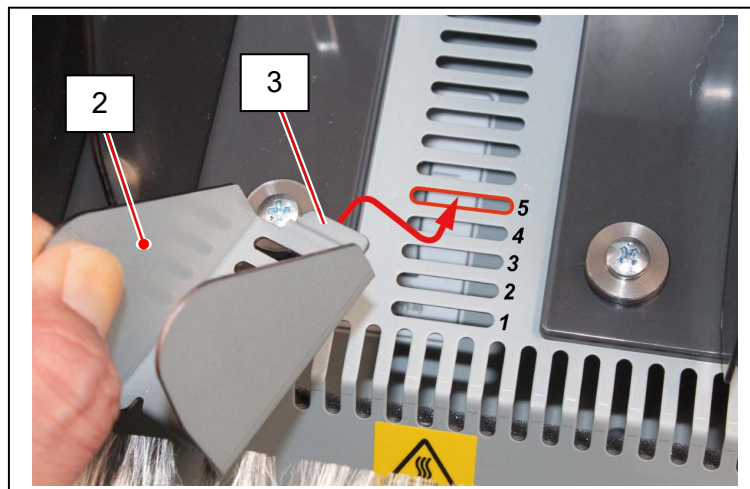

NOTE

The step (3) must be inserted to the 5th slit. If inserted to another slit the ejected pages will not be correctly stacked.

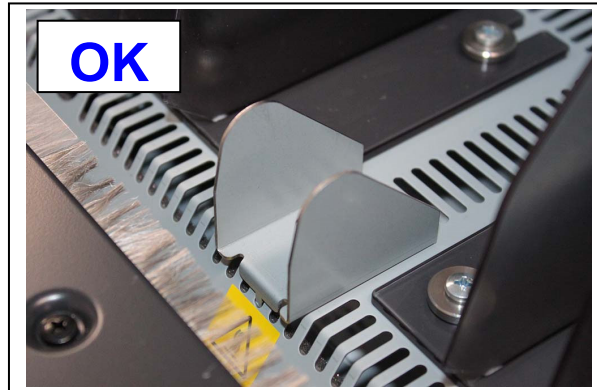

Correct : Inserted to the 5th slit



Incorrect : Inserted to the 4th slit

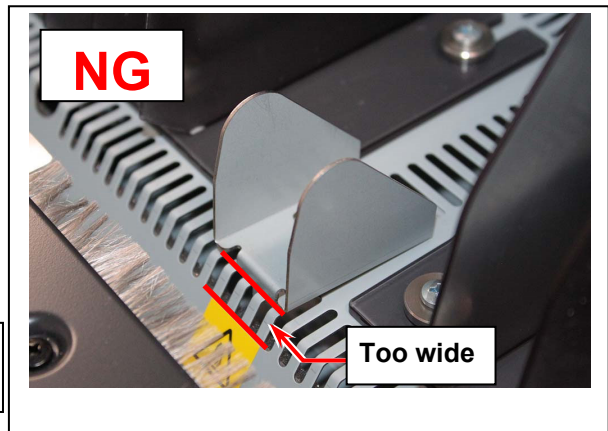

Incorrect : Inserted to the 6th slit

3. Attach the Exit Tray 2 (1).

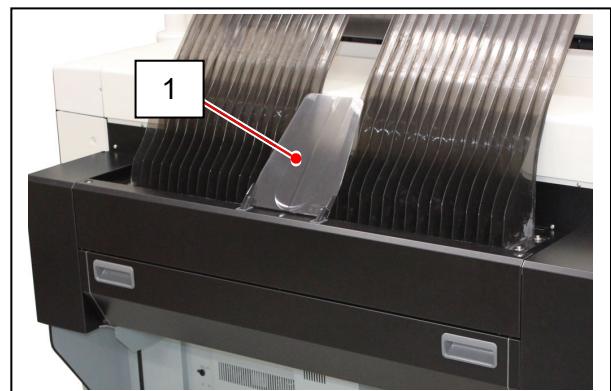

2. 8 Copying (MFP model)

For detailed information to make a copy, please refer to the "GUIDES" in the UI Home screen as well.

1. Press [COPY] in UI Home screen.

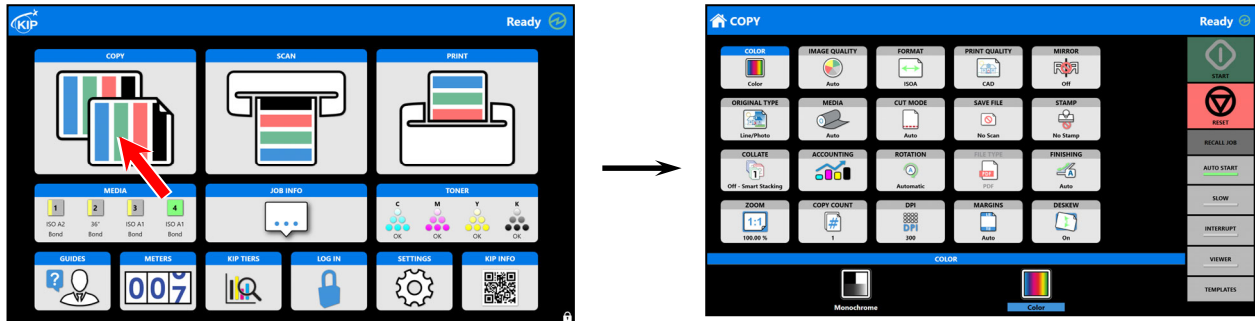

The screens may vary depending on your system configuration.
(Shown with available options)

2. There are several size markings on Original Table which indicate possible feed positions. Line up Original Guides (1) with the proper markings according to the original width.

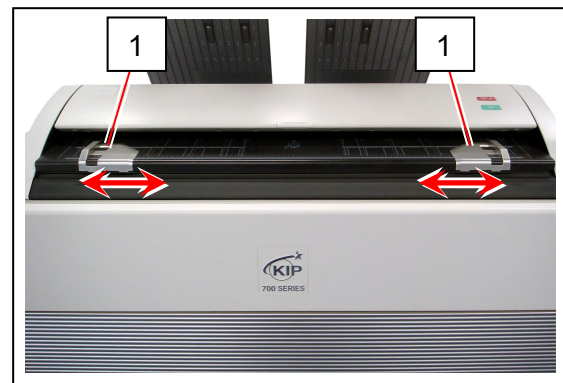

3. Place the original on the Original Table with face up. Then insert it under the Scanner Unit along with Original Guides. When the leading edge touches the original feeding roller, the machine automatically carries and sets the original at the proper position.



4. The Scanner Unit will start the copy process.

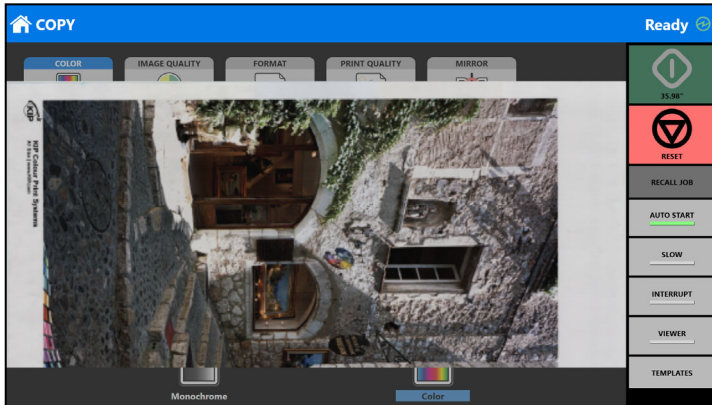

Reference

Pressing START button may be required to start the scan according to the scanner's controller software. For further details of "Auto Start", see the software's document.

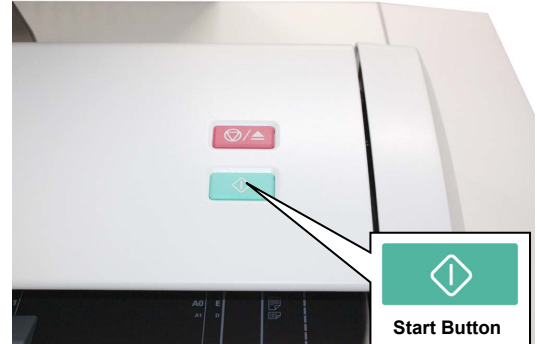

NOTE

- (1) The scanner unit does not accept originals automatically during Sleep Mode. Tap on the UI screen and then insert an original.
- (2) For the front stacking, gently lift up the prints on the print tray to the arrow direction to avoid rubbing the print surface. A large number of prints should be removed in several sheets.



Correct: Gently lift up and remove



Wrong: Do not pull downward

For the front stacking, the printer will inform you of "Upper Bin Full" on exceeding capacity of stacking. If the UI screen shows "Upper Bin Full", remove all the prints on the print tray.

2.9 Stop of Scan or Copy (MFP model)

1. If necessary, press the Scan Abort Button on the Scanner Unit to immediately stop the original while making a copy or scan.

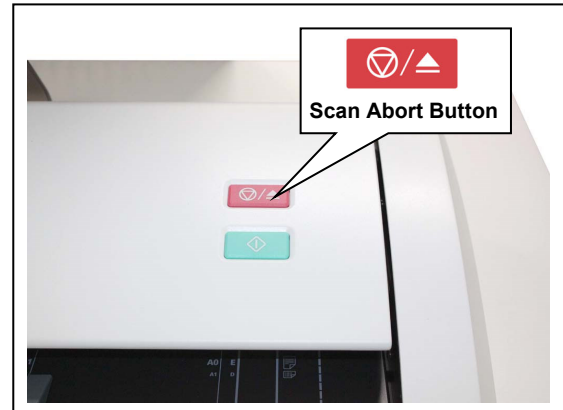

Pressing the button stops the current reading a document immediately. The current printing is stopped as well and is ejected.

NOTE

Do not pull back or hold down the original on Original Table as an attempt to stop feeding it through Scanner Unit.

2. Lift up both sides of the Scanner Unit, and then remove a mis-fed original.
3. Gently press the Scanner Unit down and firmly close it.

Chapter 3

Error Correction

3.1 Mis-feed Error	page
3.1.1 Roll Deck Section Jam (Deck 1, 2 Mis-feed)	3- 2
3.1.2 Media Feed Section Jam (Registration Mis-feed, Feeder part Mis-feed (3))	3- 3
3.1.3 Separation Section Jam (Separation Mis-feed (1))	3- 6
3.1.4 Exit Section Jam (Exit Back Mis-feed, Exit Top Mis-feed)	3- 9
3.1.5 Scanner section Jam (Scanner document jam) (MFP model)	3-12
3.1.6 Door Open While in Printing	3-15
3.1.7 Unexpected Power Shutdown While in Printing	3-19
3.2 Door Open	3-23
3.2.1 Roll Deck (Deck 1 Open)	3-23
3.2.2 Fuser Cover (Fuser Cover Open)	3-23
3.2.3 Left Side Cover (Left Side Cover Open)	3-24
3.2.4 Scanner Unit (Scanner feeder Open)	3-24
3.3 Other Operator Call	3-25
3.3.1 Roll Replacement	3-25
3.3.2 Toner Empty	3-25
3.3.3 Waste Cartridge full	3-26
3.4 Service Call Error	3-27

3.1 Mis-feed Error

"XXXX Mis-feed" is displayed in the UI screen when the media is jammed.

The jammed location when displaying "Mis-feed" is shown below.

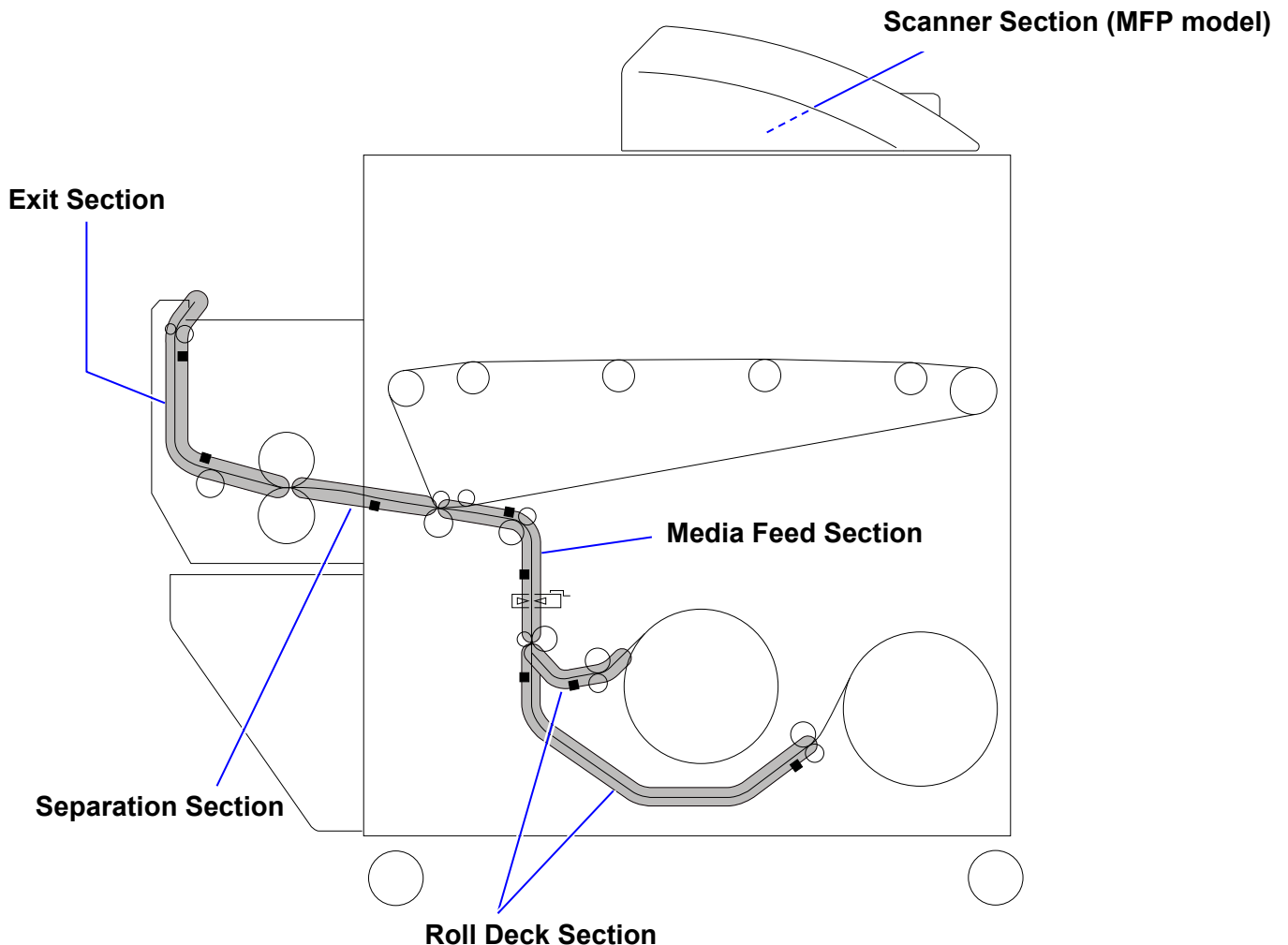

⚠ NOTE

- (1) Be careful not to get paper cuts on your hand.
- (2) Gently remove a jammed paper. When it does not reach Fuser Unit, toner on it may spill off. If toner gets into eyes or your mouth, immediately rinse them with water and contact a doctor.
- (3) Gently remove a jammed paper. When it does not reach Fuser Unit, toner on it may spill off on your cloth. Dust off your cloth. Use cold water to wash in out. Using hot water may leave a stain.

3. 1. 1 Roll Deck Section Jam (Deck 1, 2 Mis-feed)

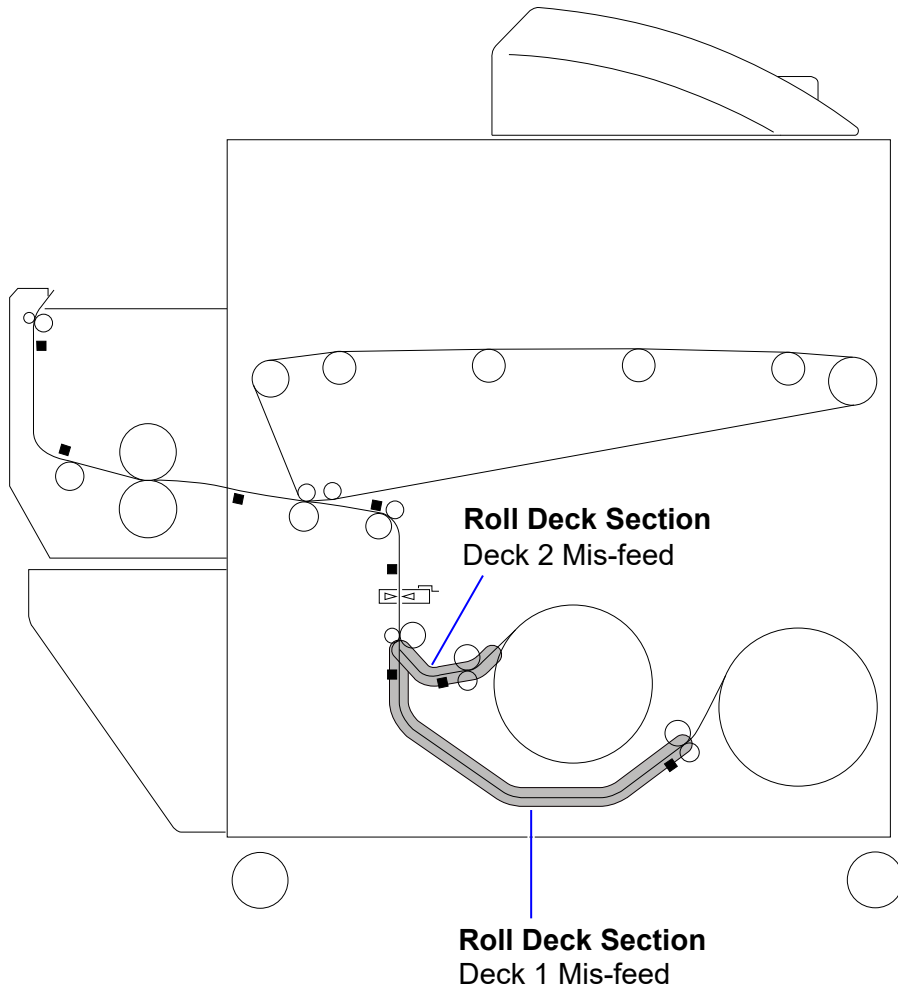

1. Open the Roll Deck (1) in issue. And then rewind the roll onto the media core.

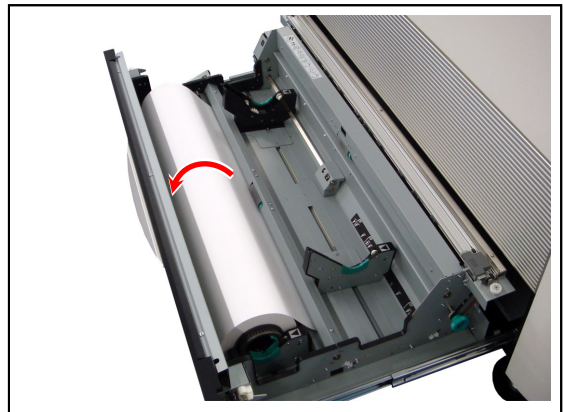
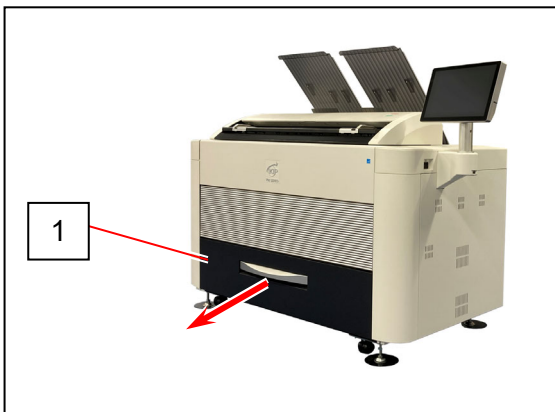

2. If the leading edge of the media is torn or folded, cut it off.

3. Set the roll media correctly.

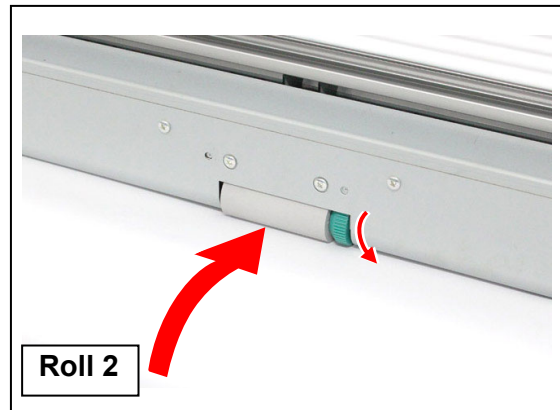
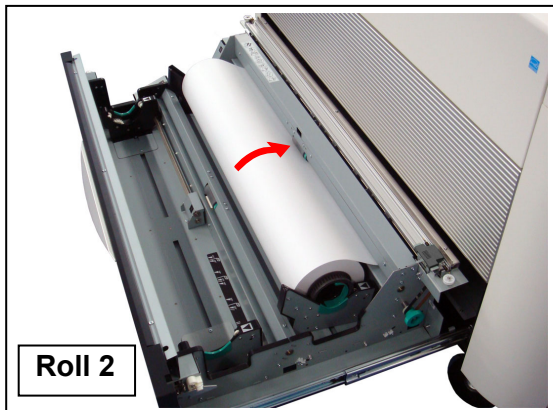
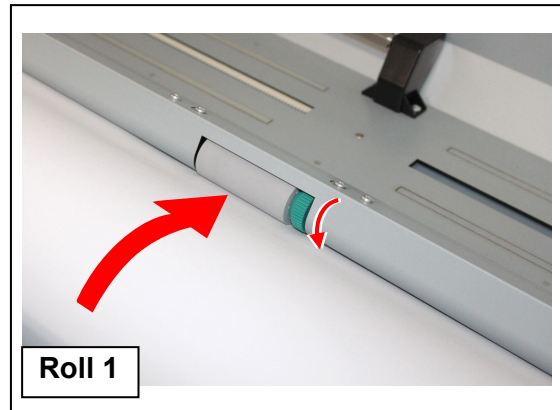
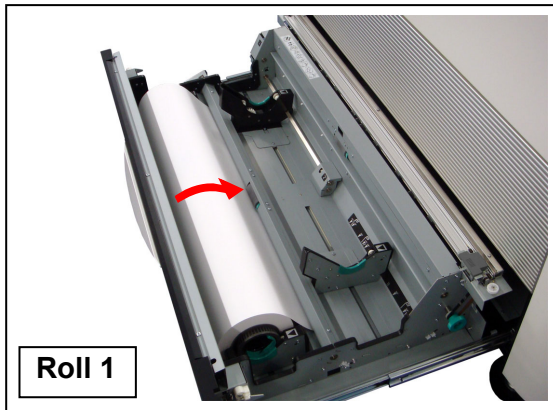
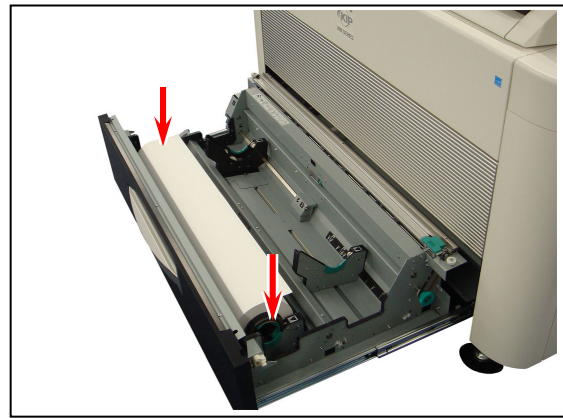

NOTE

The outside rim of Flange should meet the black triangle marked on Slide Guide. Otherwise the roll media may fall in Roll Deck or result in an incorrect media feeding.

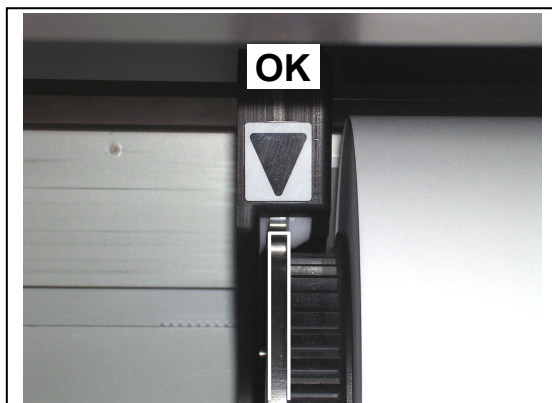

Correct

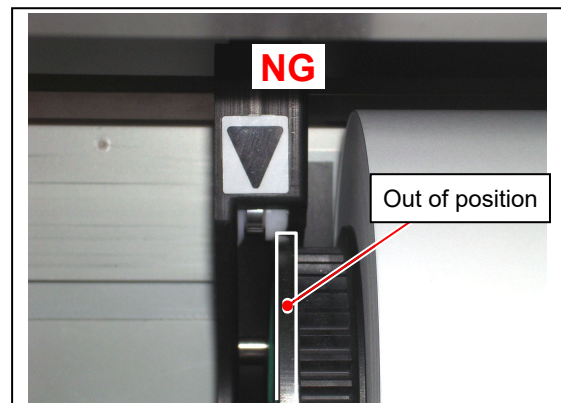

Wrong

4. Close the Roll Deck.

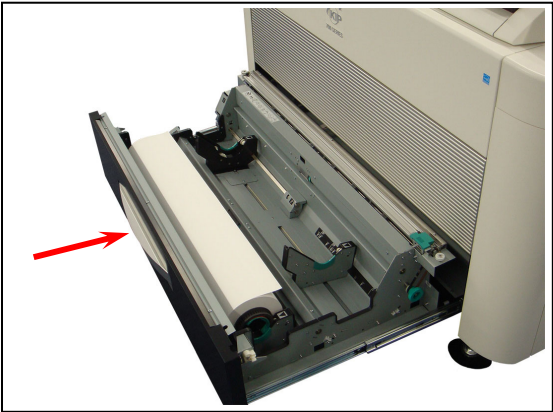

3. 1. 2 Media Feed Section Jam (Registration Mis-feed, Feeder part Mis-feed (3))

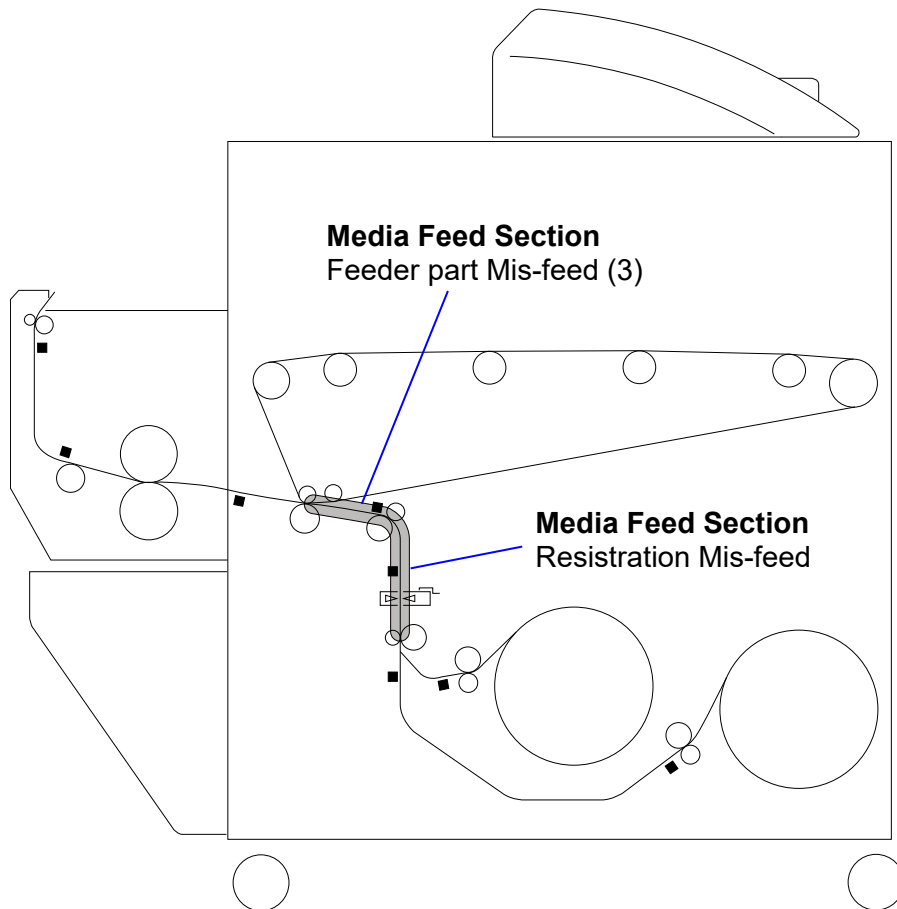

1. Open the Fuser Cover (1).

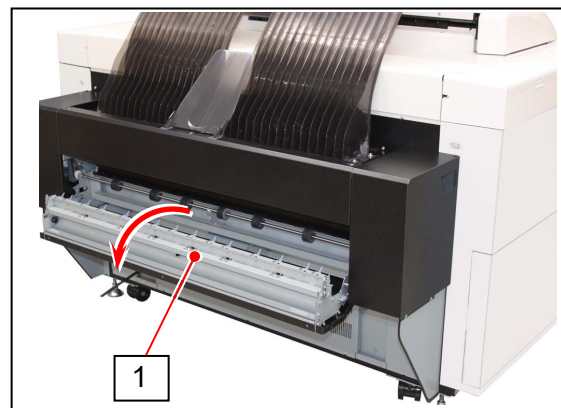

2. Pinch and gently pull and remove a jammed sheet toward you.



! WARNING

(1) There are extremely hot parts inside the Fuser Unit. Do not touch any parts in the Fuser Unit, or you will be burnt. Also the mis-fed media can be very hot. Be careful not to get burnt when you remove it.

(2) The stripping claws (2) with a sharp edge are on the inside face of the Fuser Cover. Take care not to get scratched on them when removing a sheet.

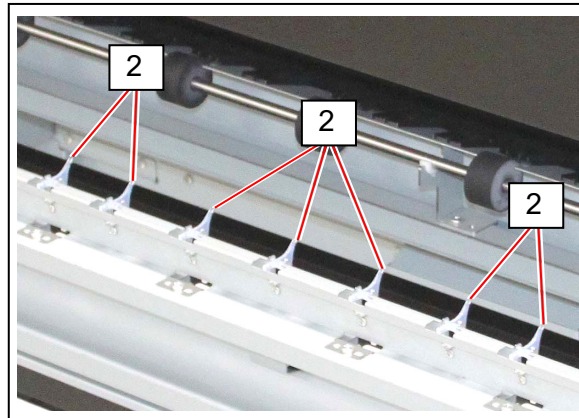

3. Close the Fuser Cover (1).

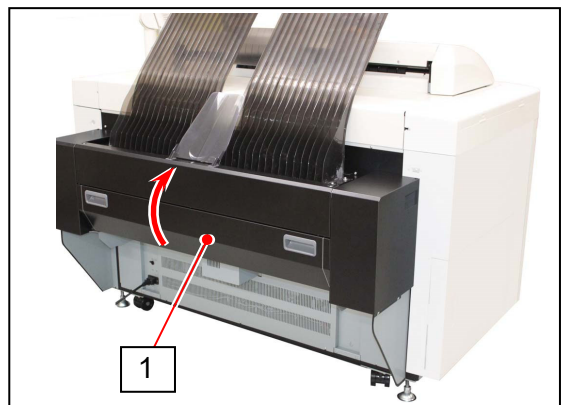

- After as many accessible remaining sheets are taken out, open the Left Side Door (3). Press Purge Switch (4) to force the printer's media drive system to forward and eject a remaining sheet that cannot be accessible on the step 2.

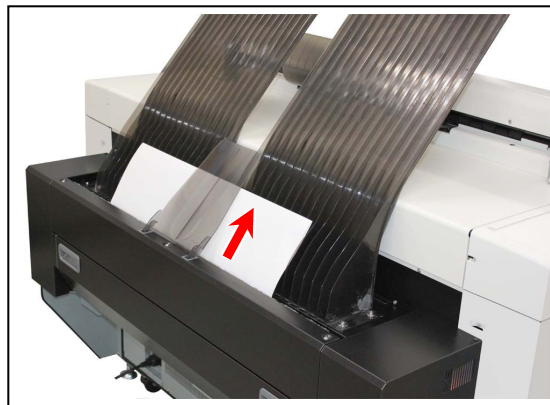
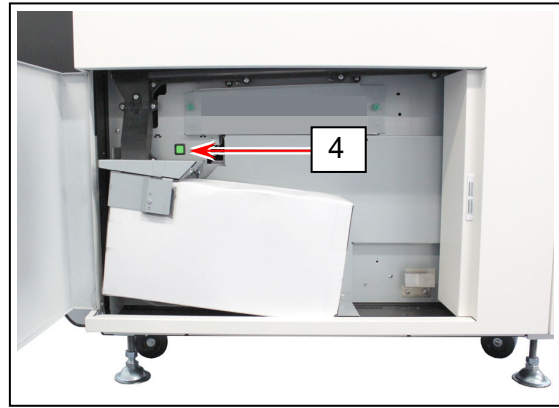
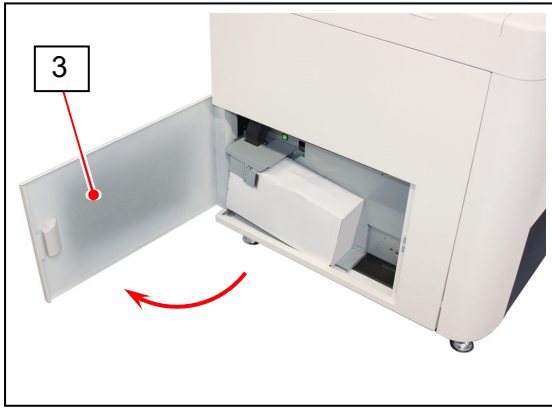

- If any sheet is still remaining even using the Purge Switch (4), loosen both the Knobs (5) to remove the Left Side Cover (6).

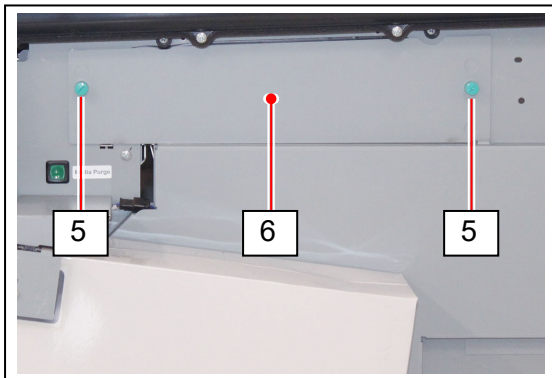

Reference

When the Left Side Cover (6) is removed, the KIP Touch UI indicates another status "Left Side Cover Open".

After removing all the sheets, return the Left Side Cover (6) in position and "Left Side Cover Open" will be cancelled automatically.

- Press and hold the Lever (7) downward and then fully move (pivot) the entire Feeder Unit (8) toward the printer's front. Take out the remaining sheet.

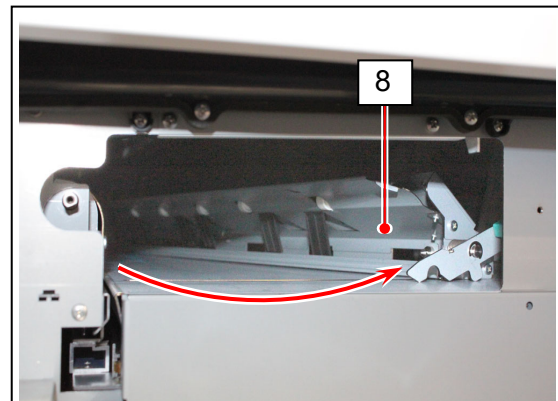
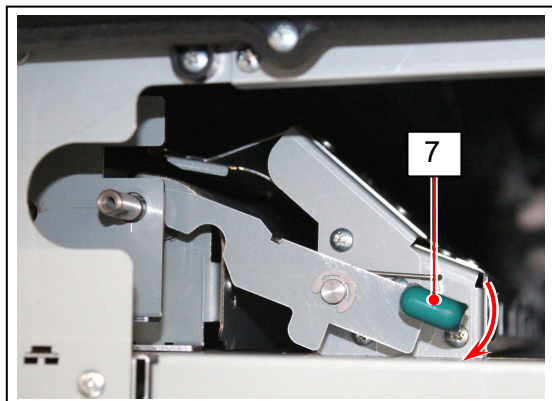

- Return the Feeder Unit (8), the Left Side Cover (6) and the Left Side Door (3) in position.

3. 1. 3 Separation Section Jam (Separation Mis-feed (1))

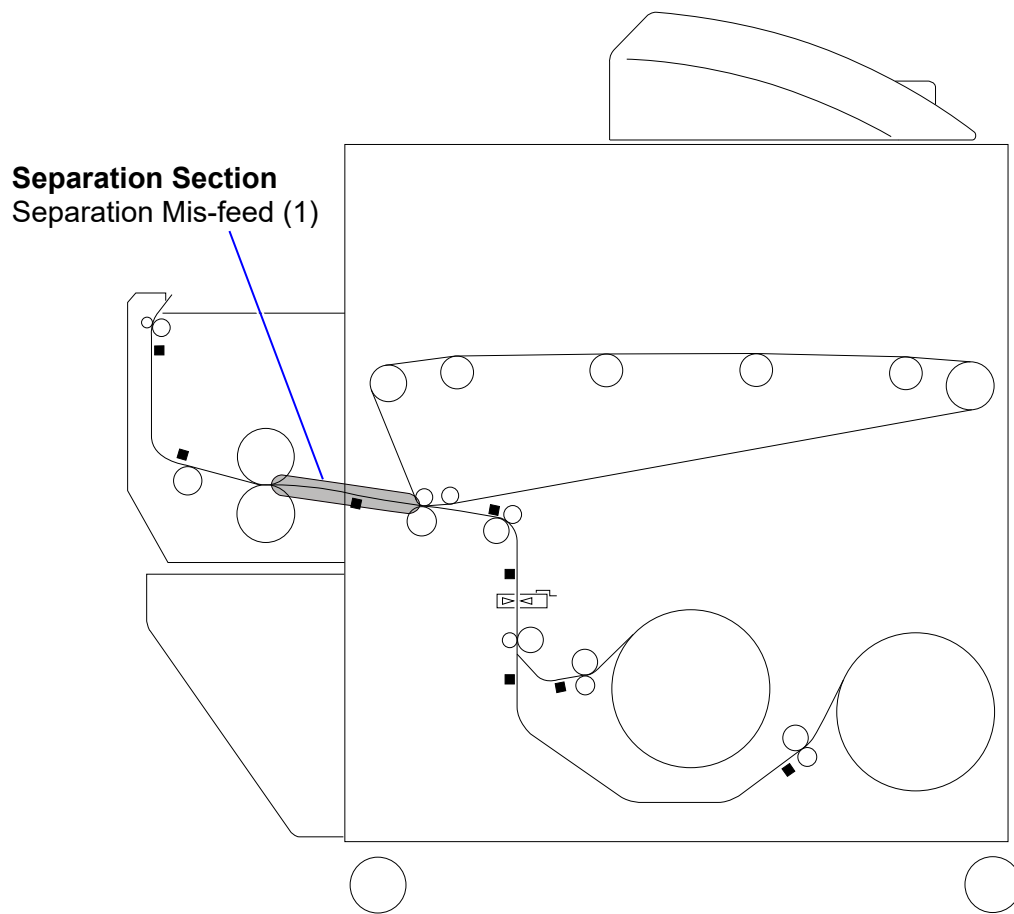

1. Open the Fuser Cover (1).

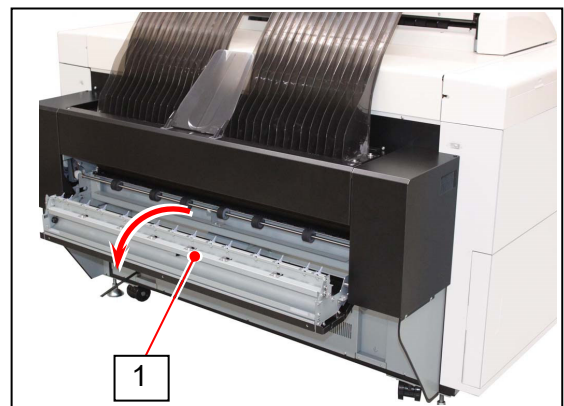

2. Pinch and gently pull and remove a jammed sheet toward you.



! WARNING

- (1) There are extremely hot parts inside the Fuser Unit. Do not touch any parts in the Fuser Unit, or you will be burnt. Also the mis-fed media can be very hot. Be careful not to get burnt when you remove it.
- (2) The stripping claws (2) with a sharp edge are on the inside face of the Fuser Cover. Take care not to get scratched on them when removing a sheet.

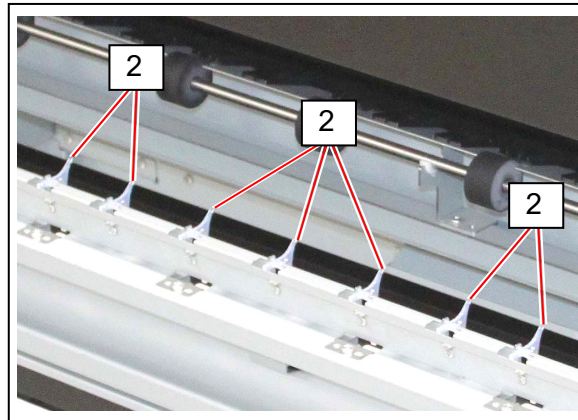

3. Close the Fuser Cover (1).

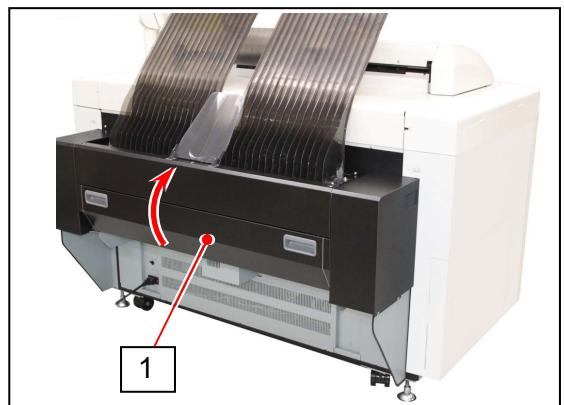

4. After as many accessible remaining sheets are taken out, open the Left Side Door (3). Press Purge Switch (4) to force the printer's media drive system to forward and eject a remaining sheet that cannot be accessible on the step 2.

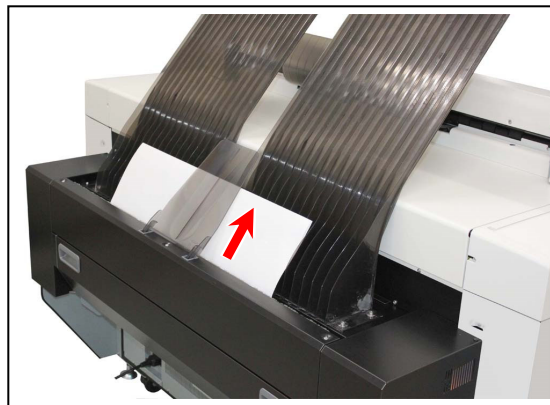
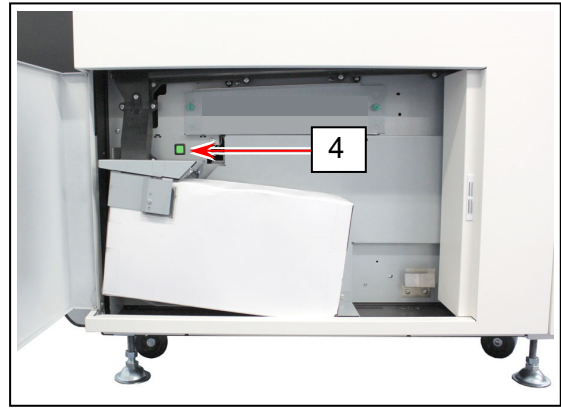
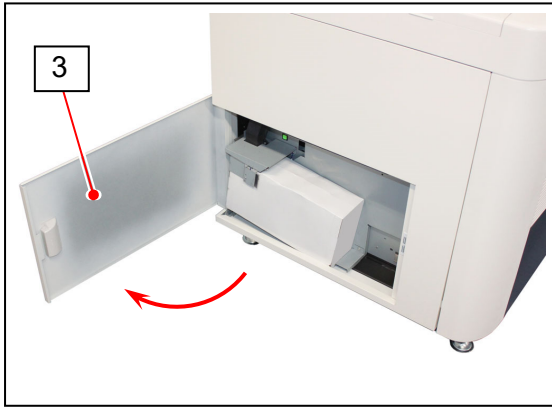

5. If any sheet is still remaining even using the Purge Switch (4), loosen both the Knobs (5) to remove the Left Side Cover (6).

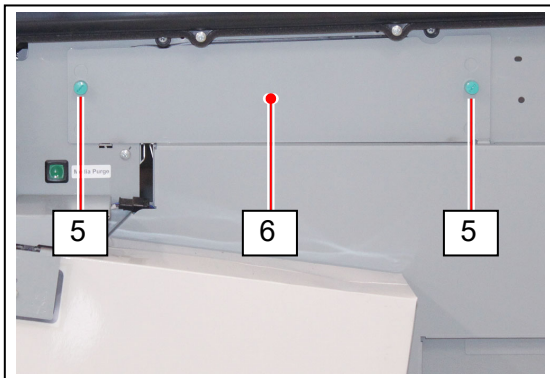

Reference

When the Left Side Cover (6) is removed, the KIP Touch UI indicates another status "Left Side Cover Open".

After removing all the sheets, return the Left Side Cover (6) in position and "Left Side Cover Open" will be cancelled automatically.

6. Press and hold the Lever (7) downward and then fully move (pivot) the entire Feeder Unit (8) toward the printer's front. Take out the remaining sheet.

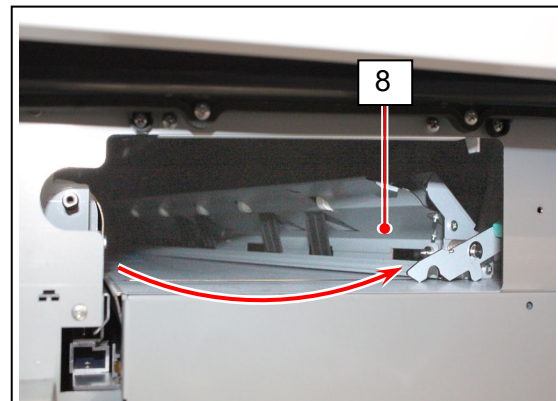
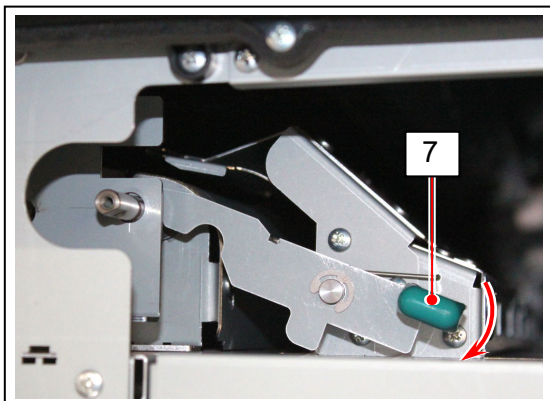

7. Return the Feeder Unit (8), the Left Side Cover (6) and the Left Side Door (3) in position.

3. 1. 4 Exit Section Jam (Exit Back Mis-feed, Exit Top Mis-feed)

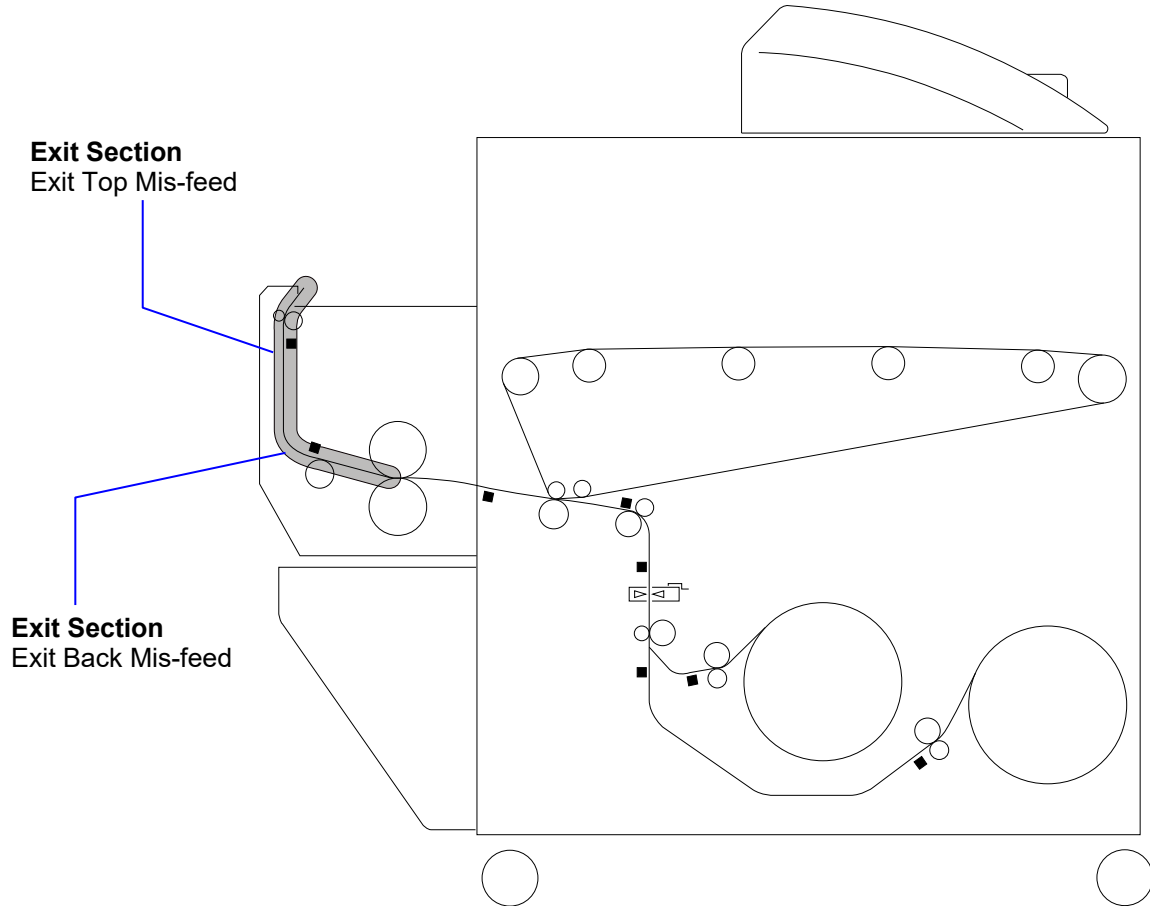

1. Open the Fuser Cover (1).

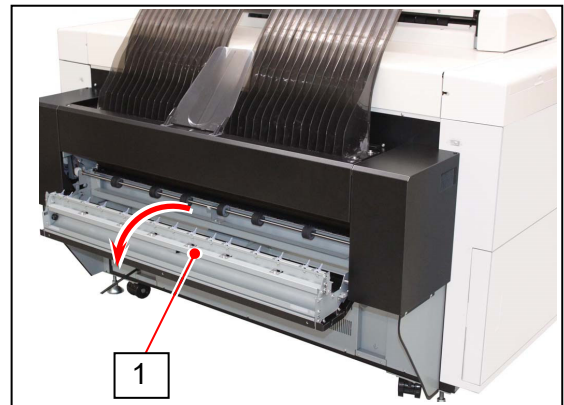

2. Pinch and gently pull and remove a jammed sheet toward you.



! WARNING

- (1) There are extremely hot parts inside the Fuser Unit. Do not touch any parts in the Fuser Unit, or you will be burnt. Also the mis-fed media can be very hot. Be careful not to get burnt when you remove it.
- (2) The stripping claws (2) with a sharp edge are on the inside face of the Fuser Cover. Take care not to get scratched on them when removing a sheet.

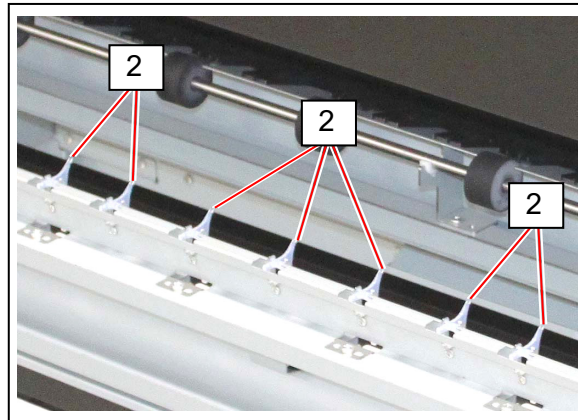

3. Close the Fuser Cover (1).

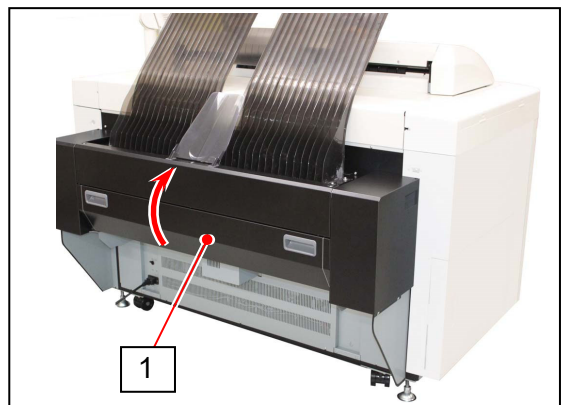

3. 1. 5 Scanner Section Jam (Scanner document jam) (MFP model)

If an original is mis-fed while scanning, the UI screen shows “Scanner document jam”. Follow the instruction below to remove the mis-fed original.

1. Lift up both sides (1) of the Scanner Unit

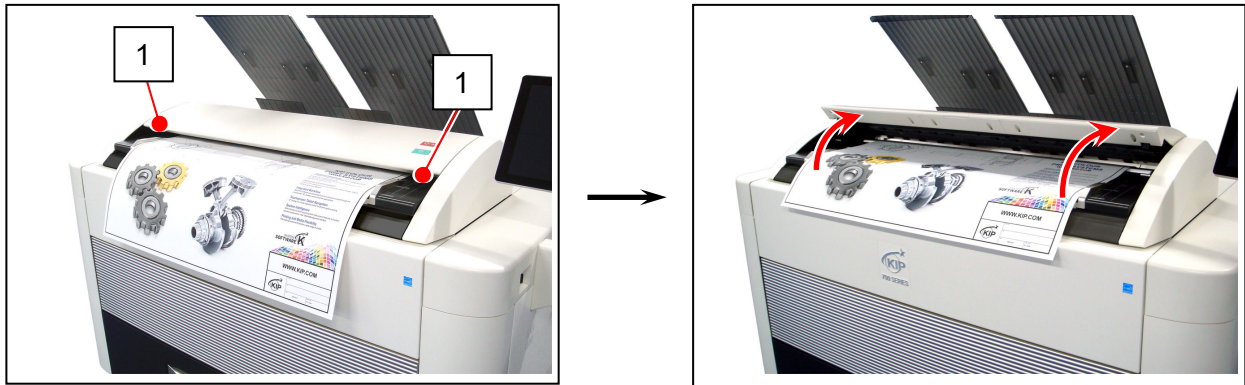

2. Remove a mis-feed original.

3. Gently press the Scanner Unit down (1) and firmly close it.

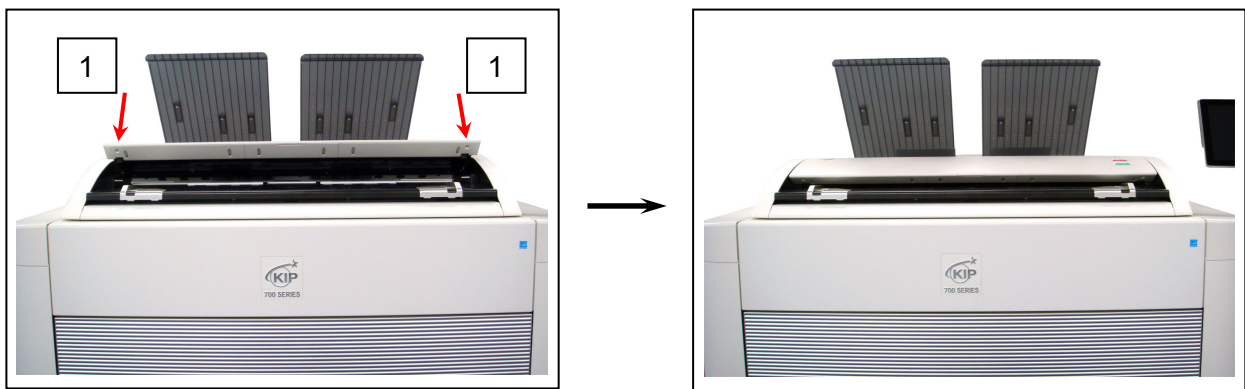

NOTE

Press down the Scanner Unit on both sides to close it.
Do not close it by pressing only one side down.

3. 1. 6 Door Open While in Printing

The printer takes a proper “print stop cycle” by cutting the media in printing and indicating the corresponding error/jam code in case of an error/jam.

But it does not in an event if either of the Roll Deck, the Fuser Cover or the Left Side Door opens by accident. In this case, follow the instruction below so that the media in printing can be manually cut and ejected.

If media stops safely:

1. Close any half-shut doors such as the Roll Deck (1), the Fuser Cover (2) or the Left Side Door (3).

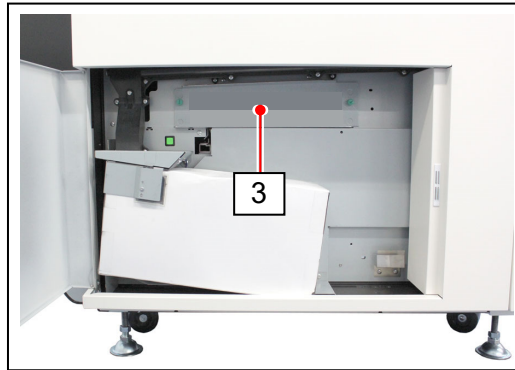
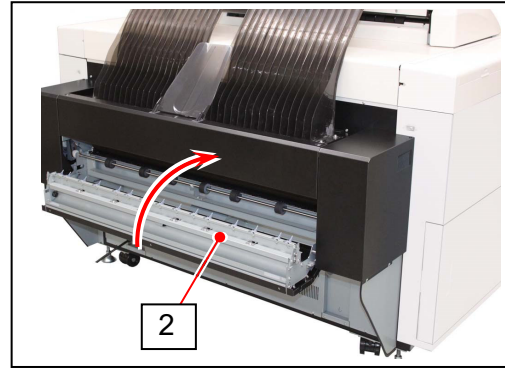
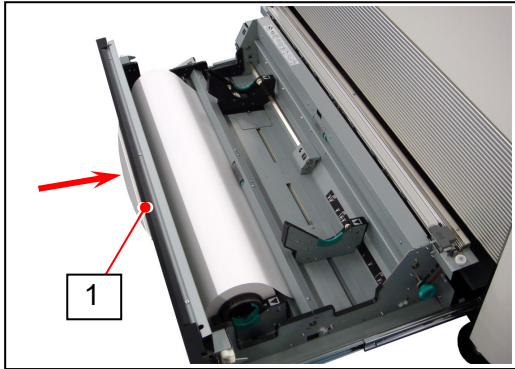

2. Press and hold the Purge Switch (4) until the media is cut, and the sheet (5) is ejected.

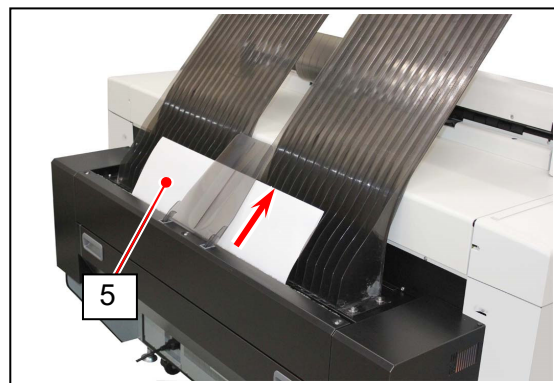
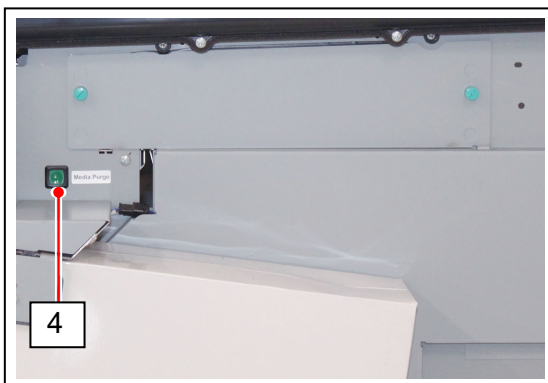

3. When the sheet is ejected, release the Purge Switch (4).

If the sheet is jammed in Fuser and is not ejected automatically:

1. Close any half-shut doors such as the Roll Deck (1), the Fuser Cover (2) or the Left Side Door (3).

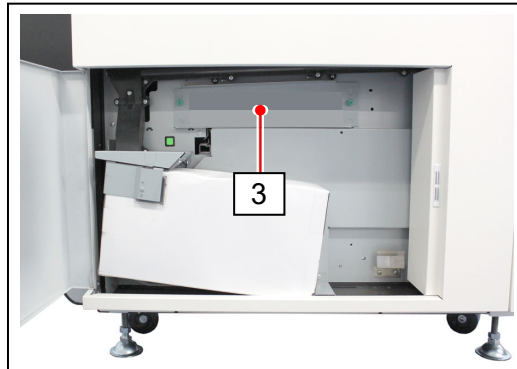
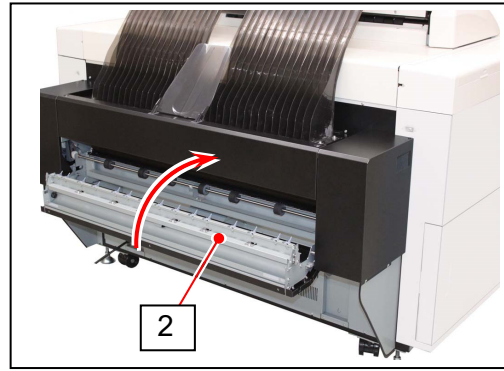
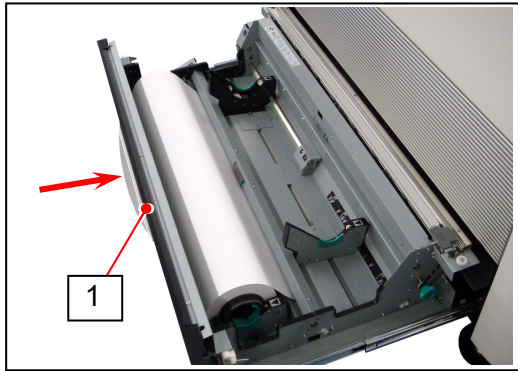

2. Press and hold the Purge Switch (4) until the media is cut.
Release the Purge Switch right after the media is cut.

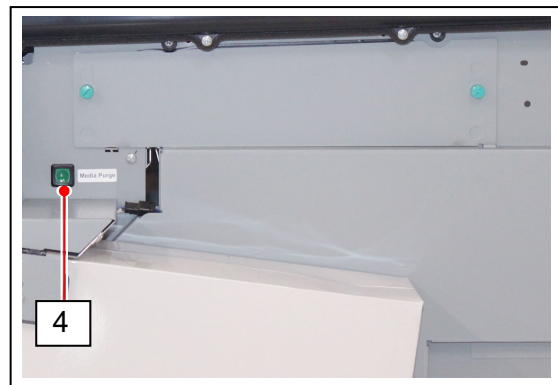

3. Open the Fuser Cover (2), and carefully pull and remove the jammed sheet (5).

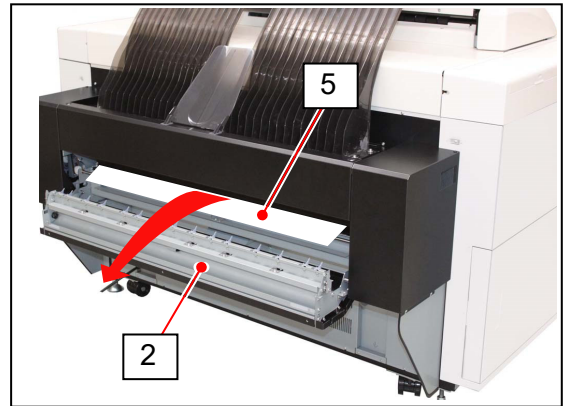

⚠ WARNING

- (1) There are extremely hot parts inside the Fuser Unit. Do not touch any parts in the Fuser Unit, or you will be burnt. Also the mis-fed media can be very hot. Be careful not to get burnt when you remove it.
- (2) The stripping claws (6) with a sharp edge are on the inside face of the Fuser Cover. Take care not to get scratched on them when removing a sheet.

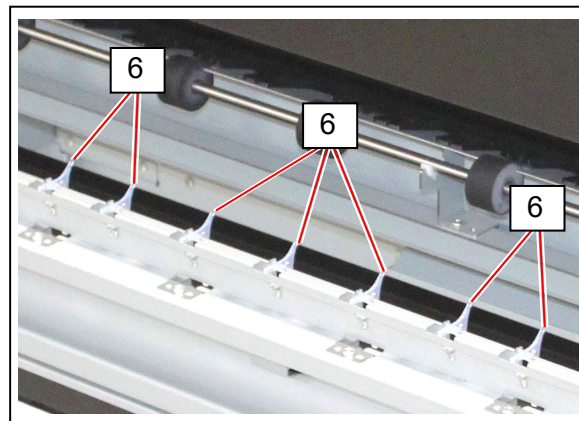

4. Open the Left Side Door (7). Loosen 2 Knobs (8) to detach the Left Side Cover (3).

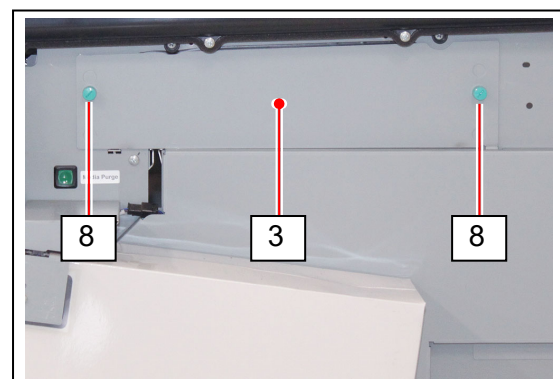
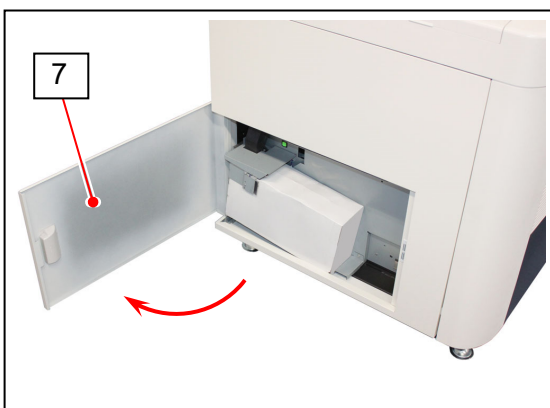

5. Press and hold the Lever (9) downward and then fully move (pivot) the entire Feeder Unit (10) toward the printer's front. Take out a remaining (portion of) sheet.

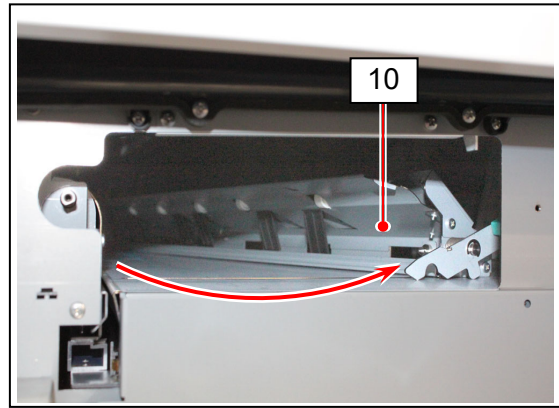
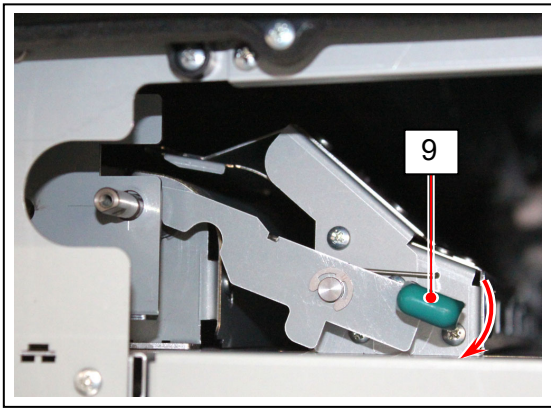

6. Return the Feeder Unit (10), the Left Side Cover (3) and the Fuser Cover (2) in position.

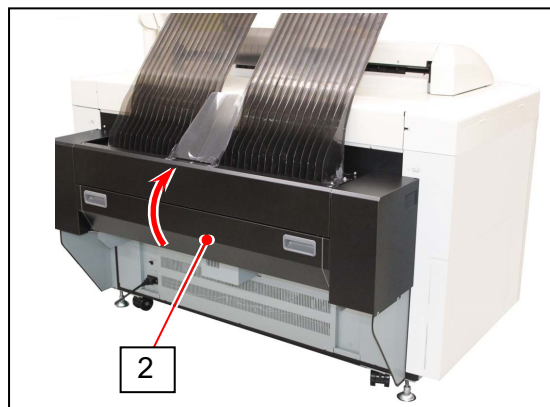
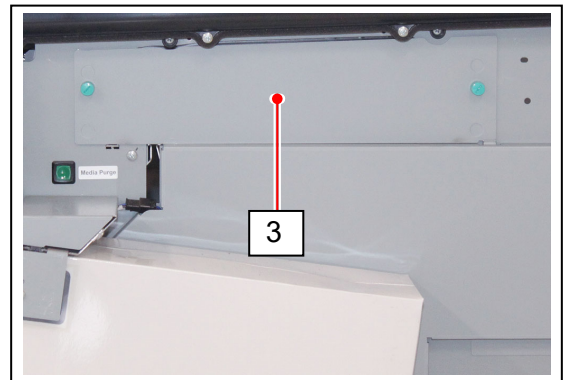
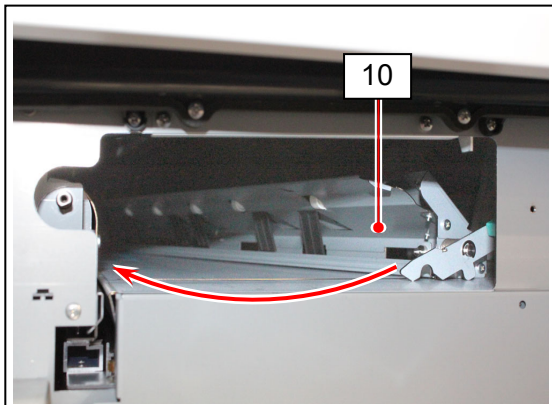

3. 1. 7 Unexpected Power Shutdown While in Printing

In case of an unexpected blackout, turning off the machine by accident or power cord unplugged, the media is not able to be cut by pressing the Purge Switch. Please follow the instruction below.

1. Open the Fuser Cover (1).

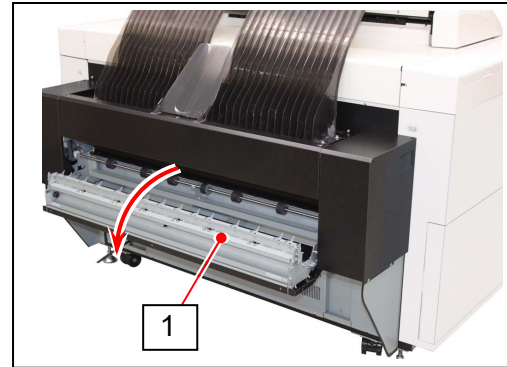

2. Open the Left Side Door (2). Loosen 2 Knobs (3) to detach the Left Side Cover (4).

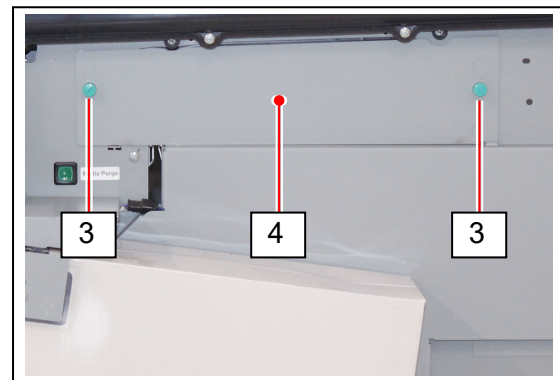
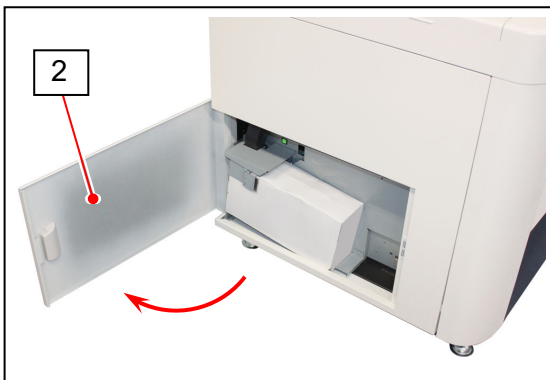

3. Press and hold the Lever (5) downward and then fully move (pivot) the entire Feeder Unit (6) toward the printer's front.

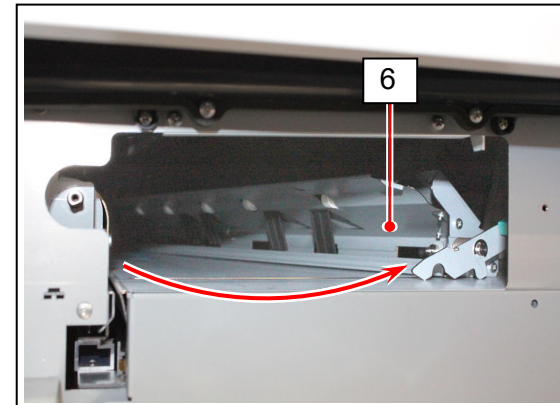
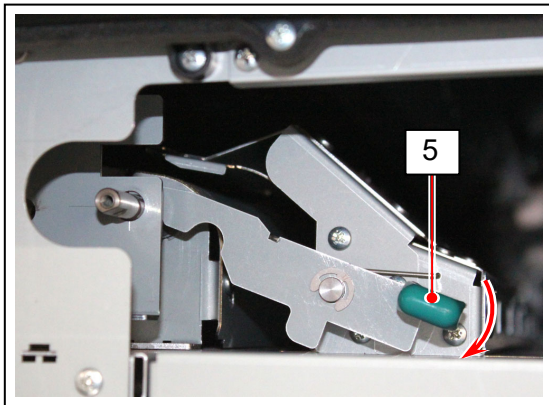

4. Open the Roll Deck (7).

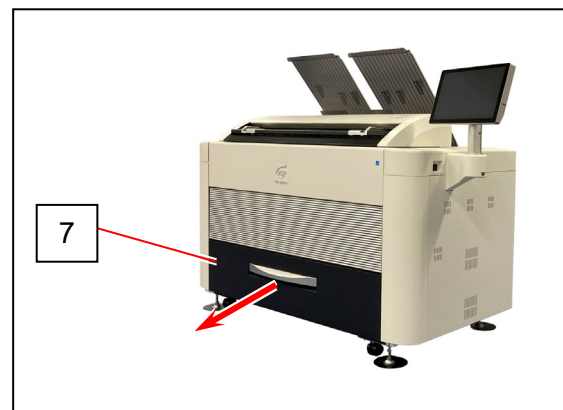

5. Slide the green Tab (8) from one end to the other end at a time. The leading edge section that is coming out from the slit is cut off, and this straightens the leading edge of the roll media.

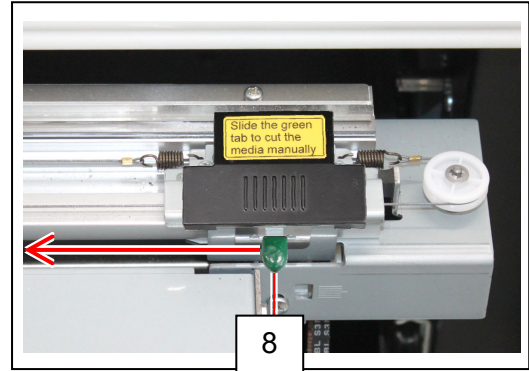
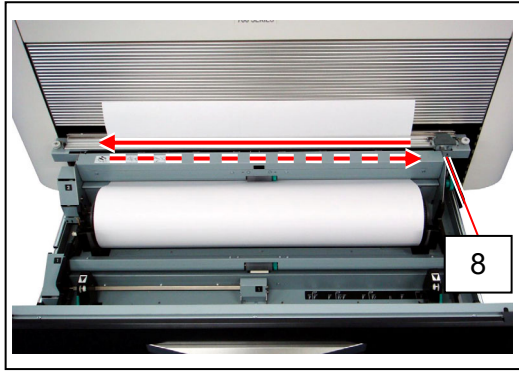

! NOTE

Please surely follow below instructions when sliding the green Tab. Incorrect operation will lead you to the damage to the Cutter Unit.

- (1) When you slide the green Tab to the right or left to cut the media, please do not pull it to the front because it will cause to damage the cutter unit.
- (2) Please hold only the green Tab when sliding the cutter. Please do not hold any other part as it can cause to damage the Cutter Unit.



6. Carefully pull and remove the jammed sheet (9) from the rear.

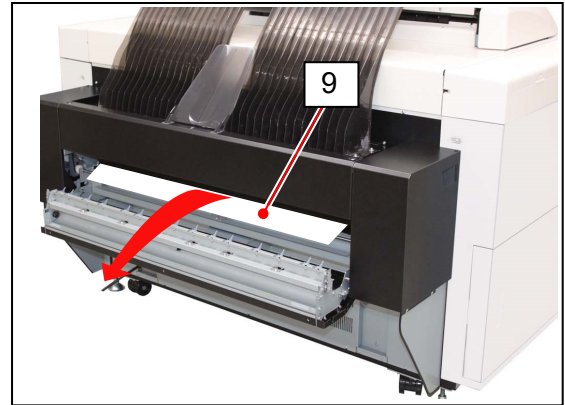

! WARNING

- (1) There are extremely hot parts inside the Fuser Unit. Do not touch any parts in the Fuser Unit, or you will be burnt.
Also the mis-fed media can be very hot. Be careful not to get burnt when you remove it.
- (2) The stripping claws (10) with a sharp edge are on the inside face of the Fuser Cover. Take care not to get scratched on them when removing a sheet.

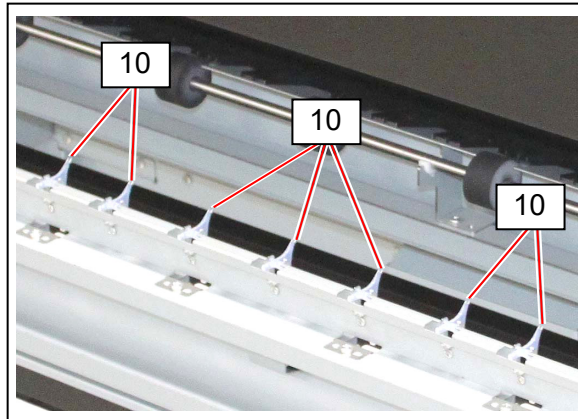

7. Return the Feeder Unit (6), the Left Side Cover (4) and the Fuser Cover (1) in position.

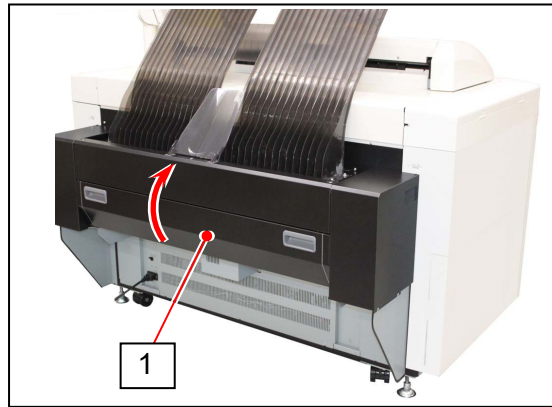
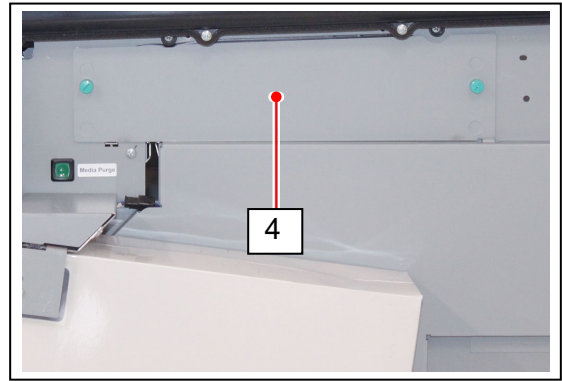
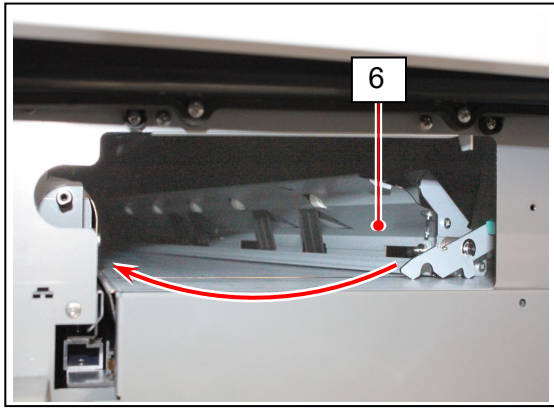

3. 2 Door Open

"Door Open" is displayed in the UI screen when the door in each unit is opened.

3. 2. 1 Roll Deck (Deck 1 Open)

Close the Roll Deck securely to clear "Deck 1 Open".

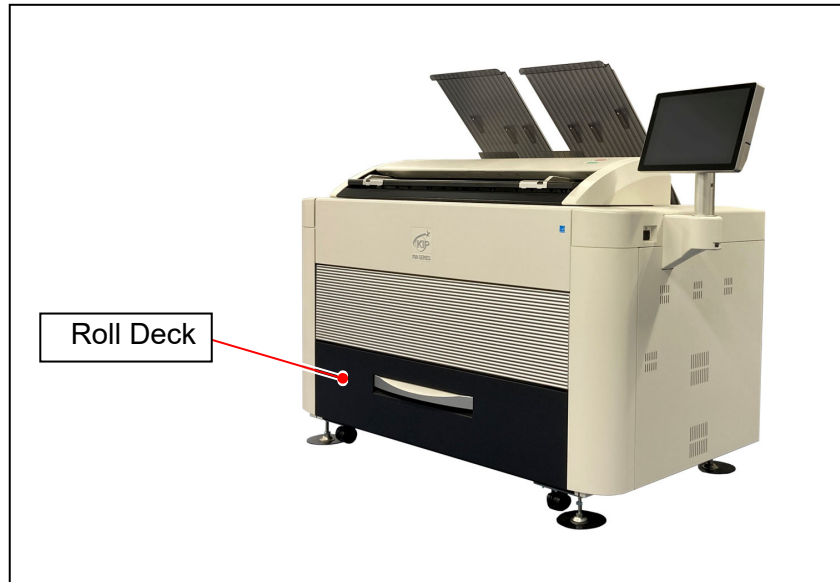

3. 2. 2 Fuser Cover (Fuser Cover Open)

Close the Fuser Cover securely to clear "Fuser Cover Open".



3. 2. 3 Left Side Cover (Left Side Cover Open)

Reinstall the Left Side Cover in position to clear “Left Side Cover Open”.
The bottom tab portion on the Left Side Cover must fit in the slit on the printer’s side plate.

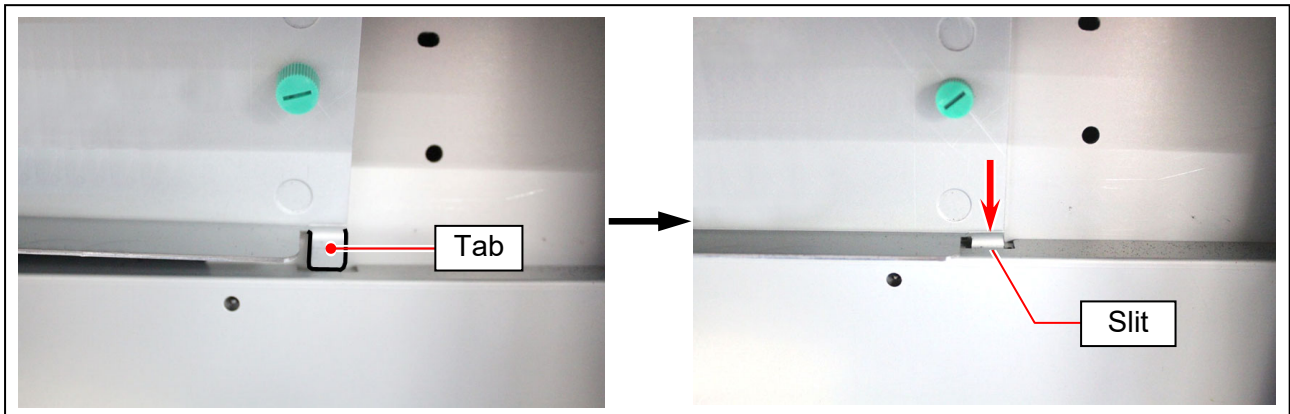
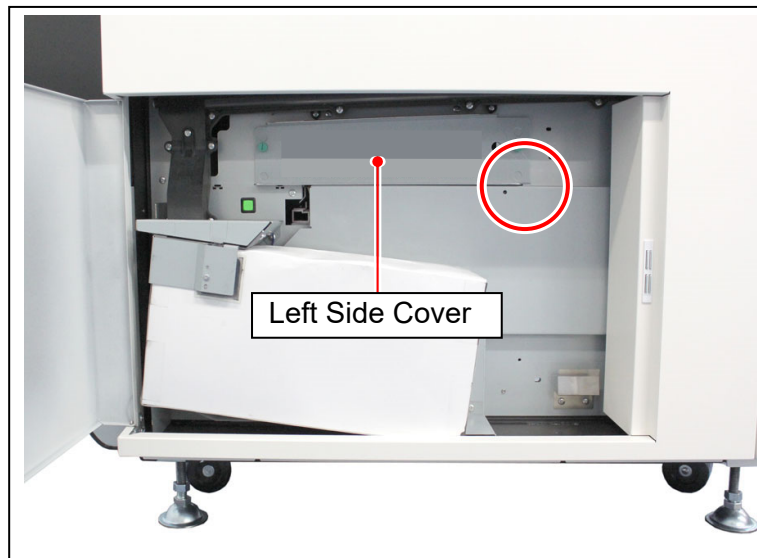

3. 2. 4 Scanner Unit (Scanner feeder open)

The UI screen shows “Scanner feeder open” if the Scanner Unit is open. (not closed properly)
Close the Scanner Unit securely to clear "Scanner feeder open".

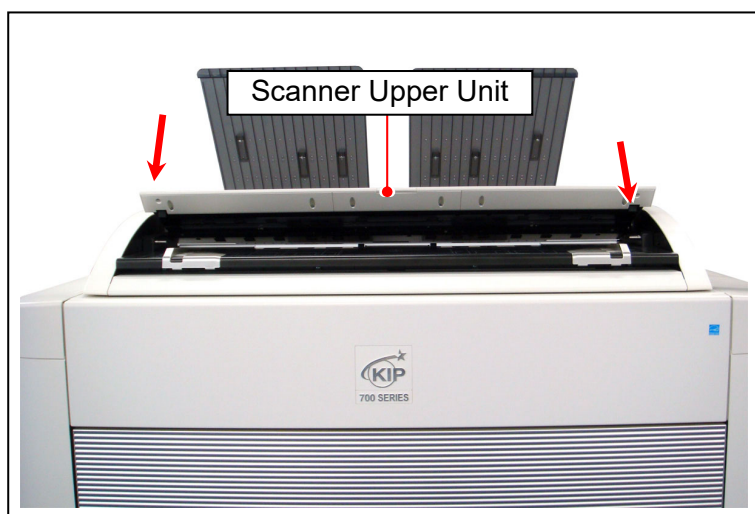

3. 3 Other Operator Call

3. 3. 1 Roll Replacement

When the printer is running out of a loaded roll media, the UI Screen will display “Out of Paper” sign.

If there is no suitable roll media required for the current print job, the UI Screen will display “Out of Paper” sign as well. Please load the required roll media to any Roll Deck.

For the roll replacement procedure, see [2.3 Replacing Roll Media].

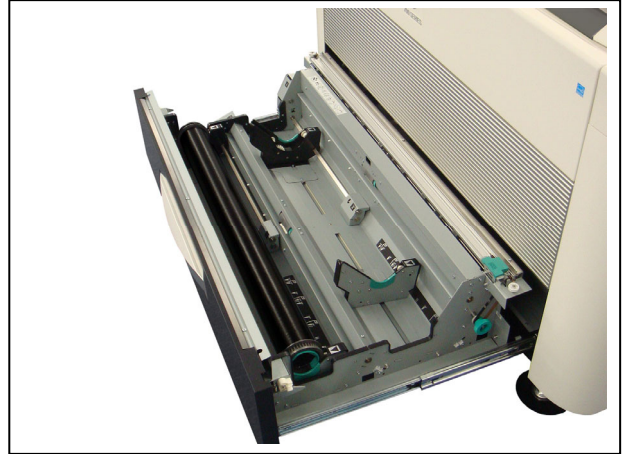

3. 3. 2 Toner Empty

When the printer is running out of toner, the UI Screen will display “Toner Empty” sign.

For the toner supply procedure, see [2.5 Toner Supply].



3. 3. 3 Waste Cartridge full

When the Toner Receptacle is full, the UI screen shows “Waste Cartridge Full.”
The printer does not restart operation until the Toner Receptacle Box is properly replaced.
For replacement procedure, see [2.6 Replacing Toner Receptacle].

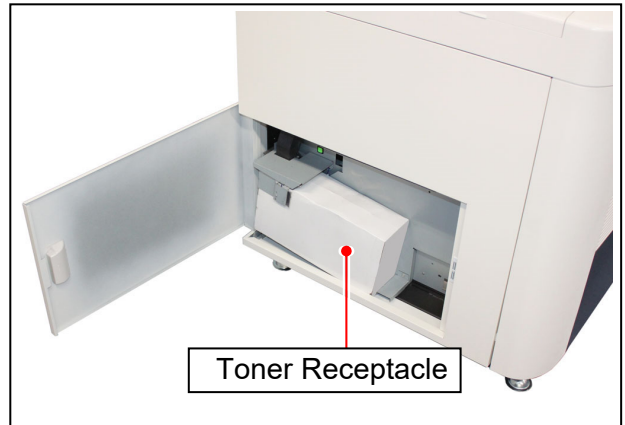

3.4 Service Call Error

If an error with significant effect on the printer occurs, the printer stops the operation and indicates the related Service Call Error (Customer Engineer Call Error) in the UI screen. Call your service staff immediately as these problems can be fixed by a well trained technician only.

Before calling the service staff, cycle the power of the printer. If the error is indicated again, turn off the printer, unplug the power cord, and then call the service staff with reporting the error code “E-xxxx”.

- Sensor Error
- Motor Error
- Cutter Error
- Fan Error
- Fusing Temperature Error
- LED Head Error
- High Voltage Power Supply Error
- Density Control Error
- Belt Skew Error
- Out of Web (Web is an embedded cleaner for the Fuser Unit)

A corresponding code/description for the error will be displayed in the top column (status region) in the UI screen.

(E-0101 shown as example)

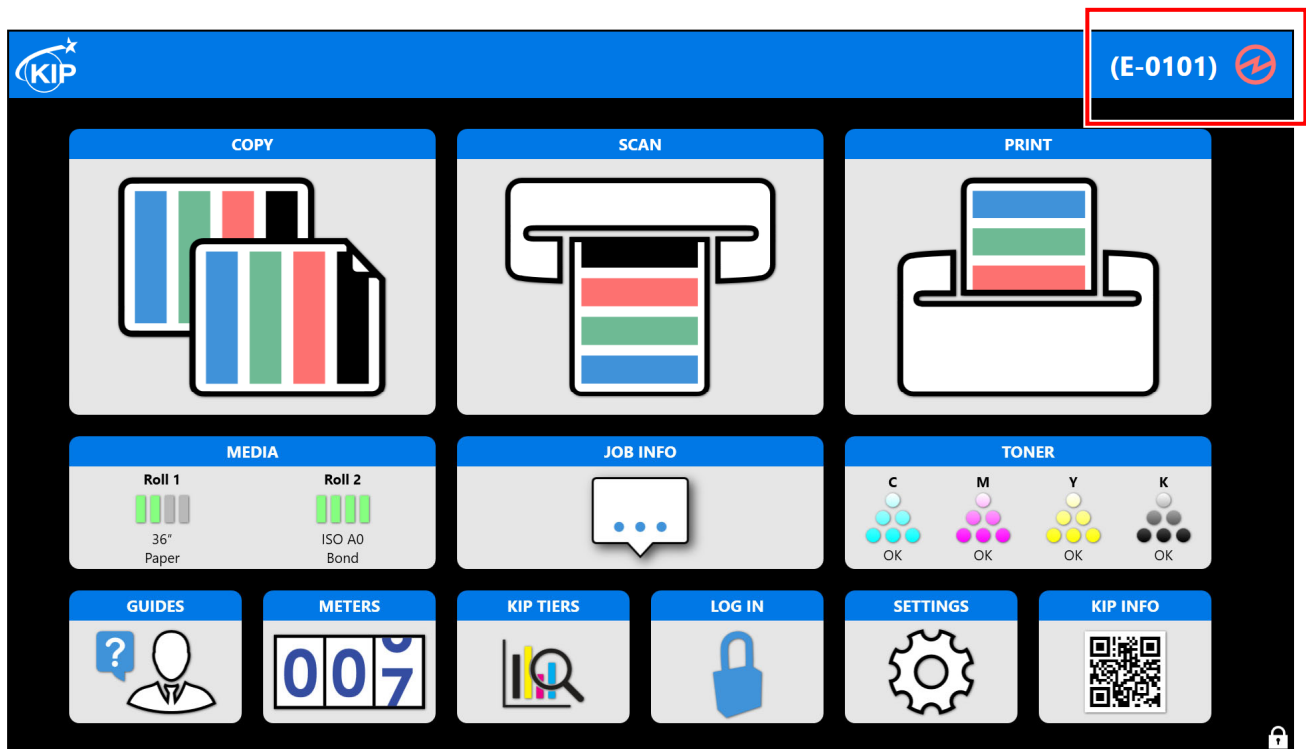

Chapter 4

Maintenance

4.1	Paper Exit section.....	page
4.1.1	Exit Rollers	4- 2
4.2	Scanner Unit (MFP model)	4- 6
4.2.1	Scan Glass, Feed Roller, Guide Plate	4- 6
4.2.2	Sensor	4- 9
4.3	Touch Screen	4-11

Before cleaning the printer, turn off the printer, wait two minutes for shutdown, and then disconnect the power cord from the wall outlet.

Wipe down the exterior surface with a soft, dry, clean cloth. To prevent the surface of your exterior cover from changing color, do not spray with or apply alcohol or the other volatile substances.

4. 1 Paper Exit section

4. 1. 1 Exit Rollers

The dirt on the Exit Rollers may be adhered to the cutting face of the trailing part on the print. For this case, please clean 6 Exit Rollers (1) on the Paper Exit section with the cloth which is wrung out the water.

For the prevention, cleaning these Exit Rollers once a week is recommended. When producing many prints, check the state of the Exit Rollers (1) and suitably clean them.

The half circumference of the exposed Exit Roller can be cleaned by one cleaning work. The entire circumference of the Exit Rollers can be evenly cleaned by the weekly cleaning.

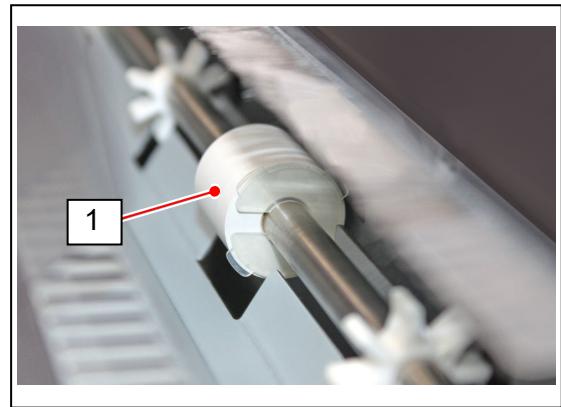
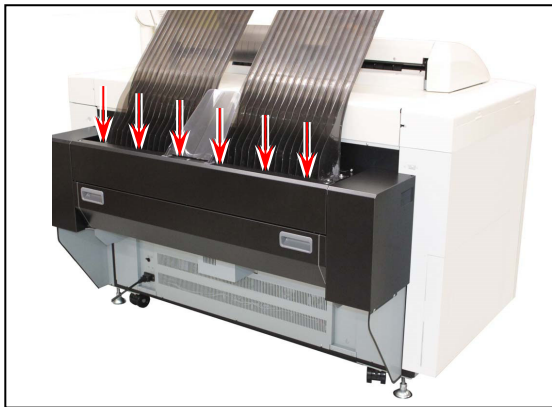

1. Remove the Exit Tray 2 (2).

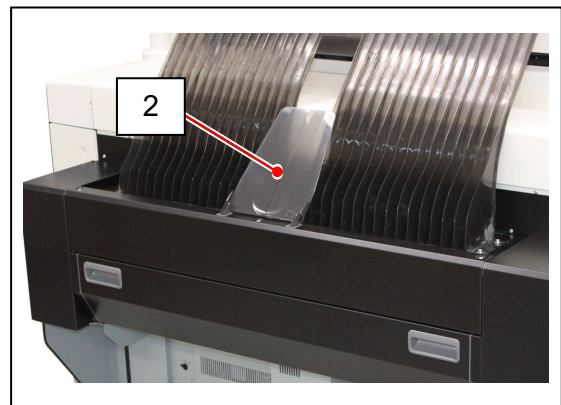

2. Remove 4 screws (M4x10) (3) to remove the Collar (4) and the Exit Tray (5).

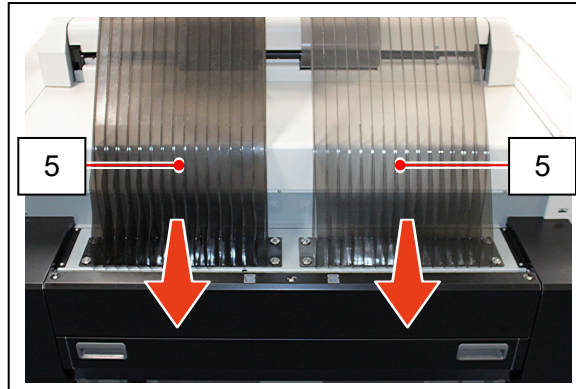
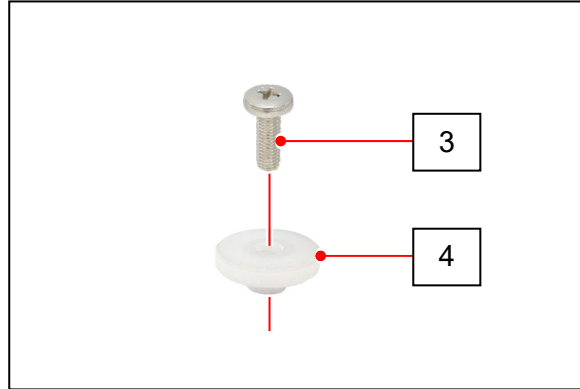
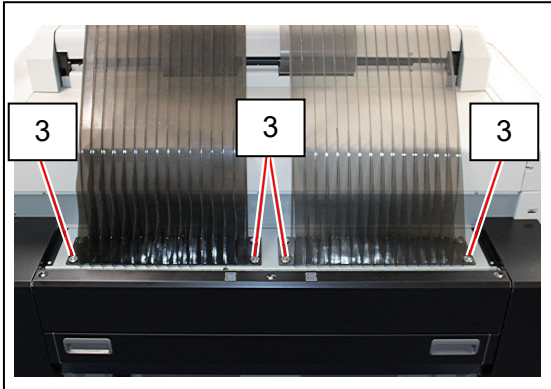

! NOTE

1. Carefully remove the Exit Tray (5) so as not to touch the Mylar (6) and the Discharging Brush (7) each other.

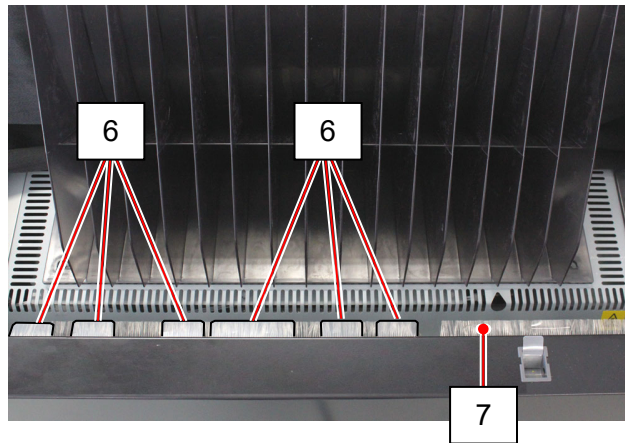

2. The Exit Trays are different between right and left. Please reattach them so that the upper tabs on them should be outside when putting back.



3. Clean 6 Exit Rollers (1) of the Paper Exit section to the arrow direction with the cloth which is wrung out the water.

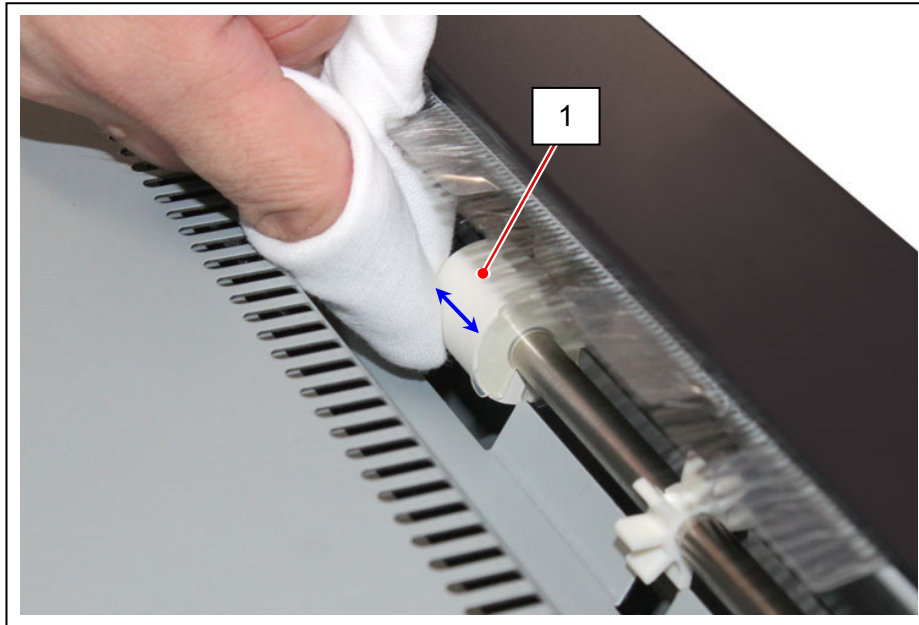

! NOTE

1. Clean the Exit Rollers when they are cold; such as "before turning on the printer".
2. Carefully clean the Exit Rollers so as not to damage the Mylar (9) adhered to 4 Exit Rollers. (There is no Mylar (9) on 2 Exit Rollers in the center.)

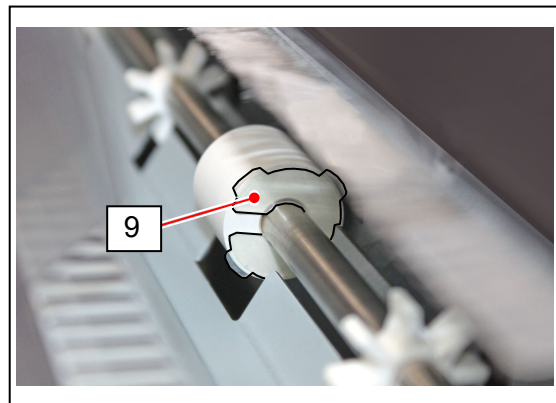

2. Carefully clean the Exit Rollers so as not to damage the Mylar (6) and the Discharging Brush (7).

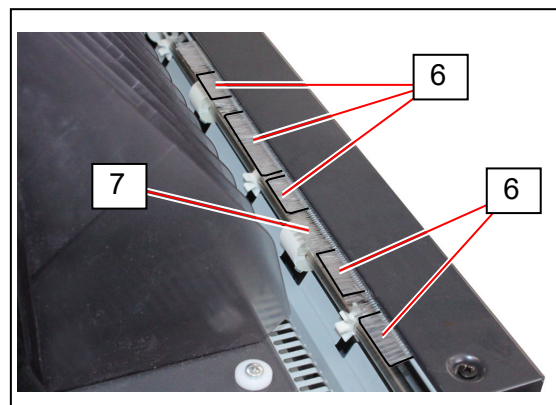

Reference

To clean the entire circumference of the Exit Rollers one time, clean the half circumference of the Exit Rollers and then turn off/on the printer.

If so, the Exit Rollers are rotated and another side (unclean side) can be cleaned.

4. 2 Scanner Unit (MFP model)

4. 2. 1 Scan Glass, Feed Roller, Guide Plate

It is recommended to clean each Scan Glass, Feeding Rollers and Guide Plates as the scan/copy image may become defective if these parts are dirty.

NOTE

For ease of visual check, this document shows the Upper Unit fully open (not actual wide).

1. Turn off the Printer.
2. Lift up both sides (1) of the Scanner Unit.

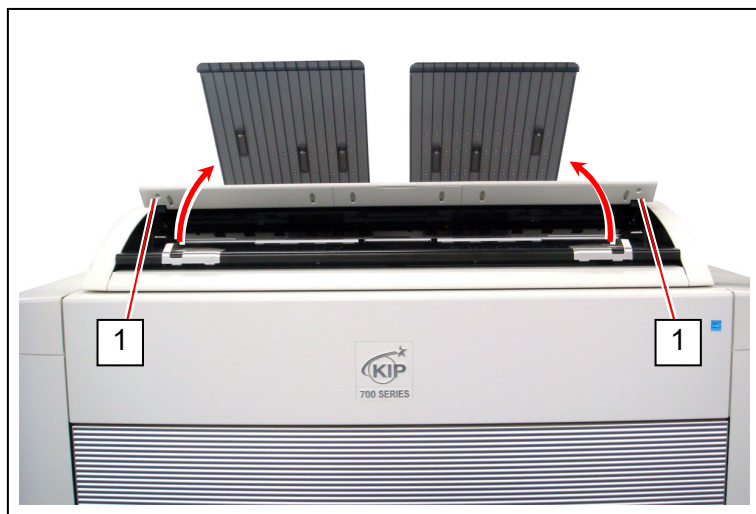

3. Gently wipe the Scan Glass (2) and Feed Rollers (white) (3) with a soft cloth. Equal mixture of water and neutral detergent can be used.

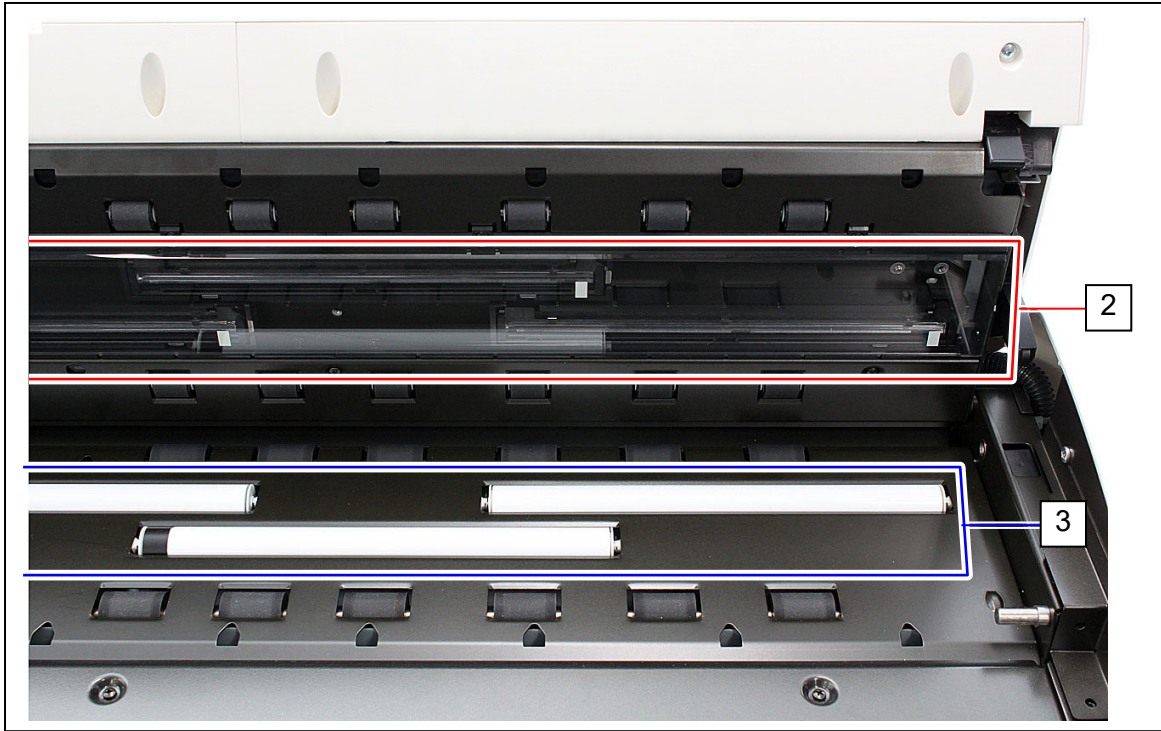

⚠ NOTE

Do not use organic solvent, glass cleaner and anti-static spray for the cleaning.

4. Wipe the Feed Rollers (rubber) (4) with a dry cloth.

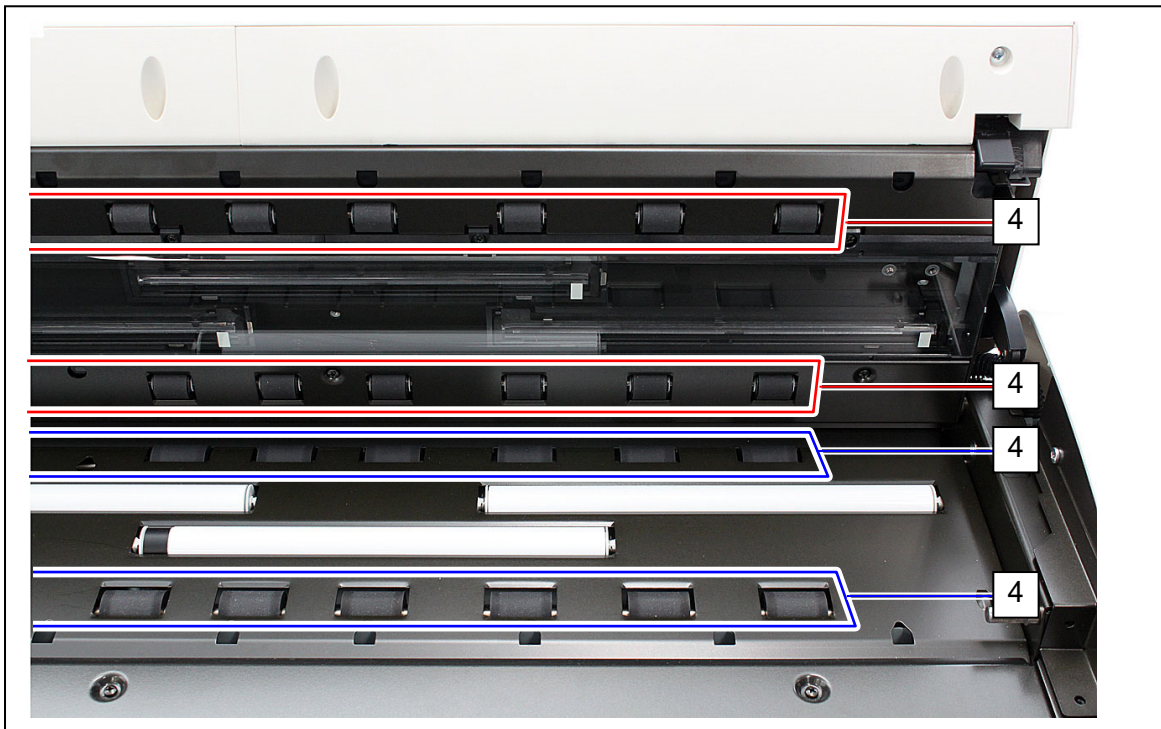

5. Wipe dry the Feeding Rollers.

6. Wipe the Upper Guide Plate (5) and the Lower Guide Plate (6) with a dry cloth.

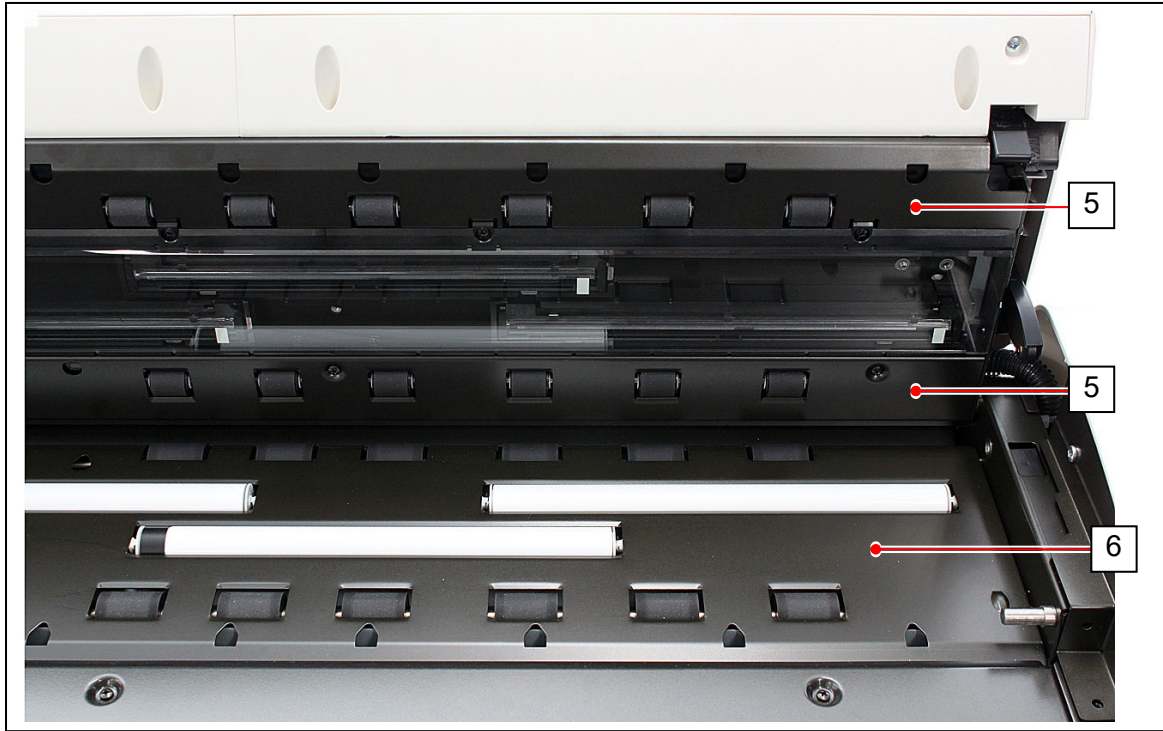

7. Gently press Scanner Unit down and firmly close it.

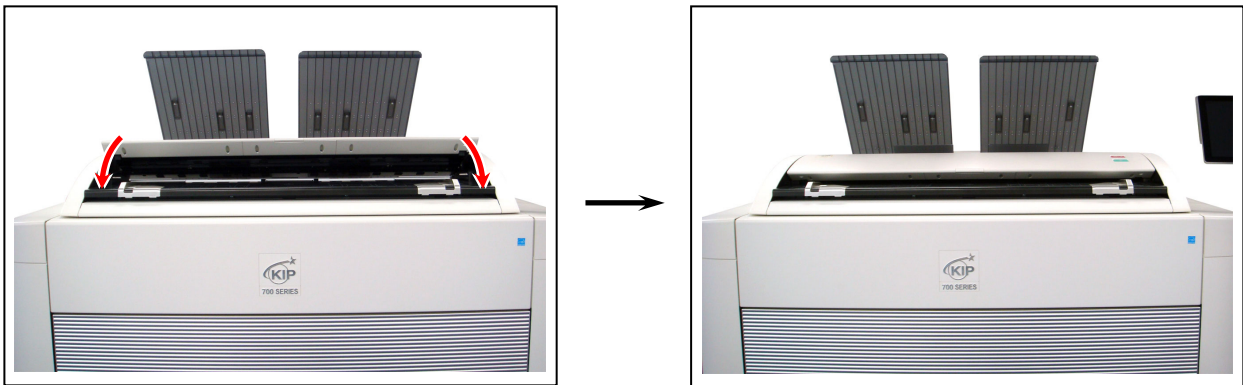

! NOTE

Press down Scanner Unit on both sides to close it.
Do not close it by pressing only one side down.

4. 2. 2 Sensor

If Sensors are dirty, the original may be detected incorrectly.
Perform cleaning or as needed.

! NOTE

For ease of visual check, this document shows the Upper Unit fully open (not actual wide).

1. Turn off the Printer.
2. Lift up both sides (1) of the Scanner Unit.

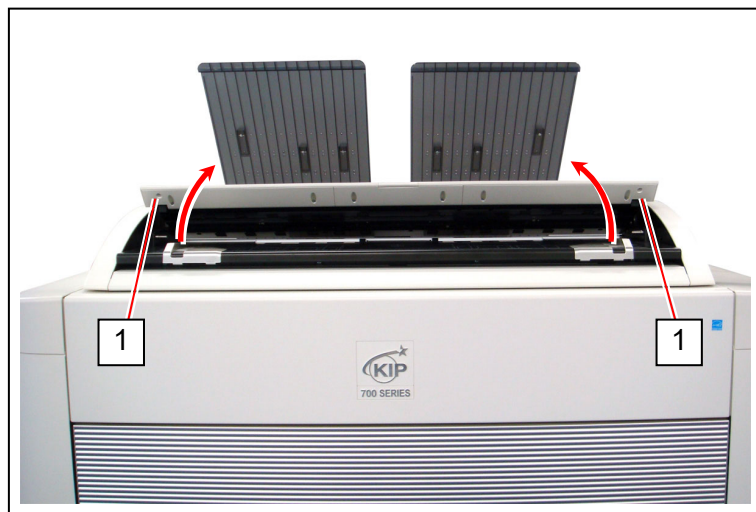

3. Gently wipe Sensors (2) with a dry cotton bud.

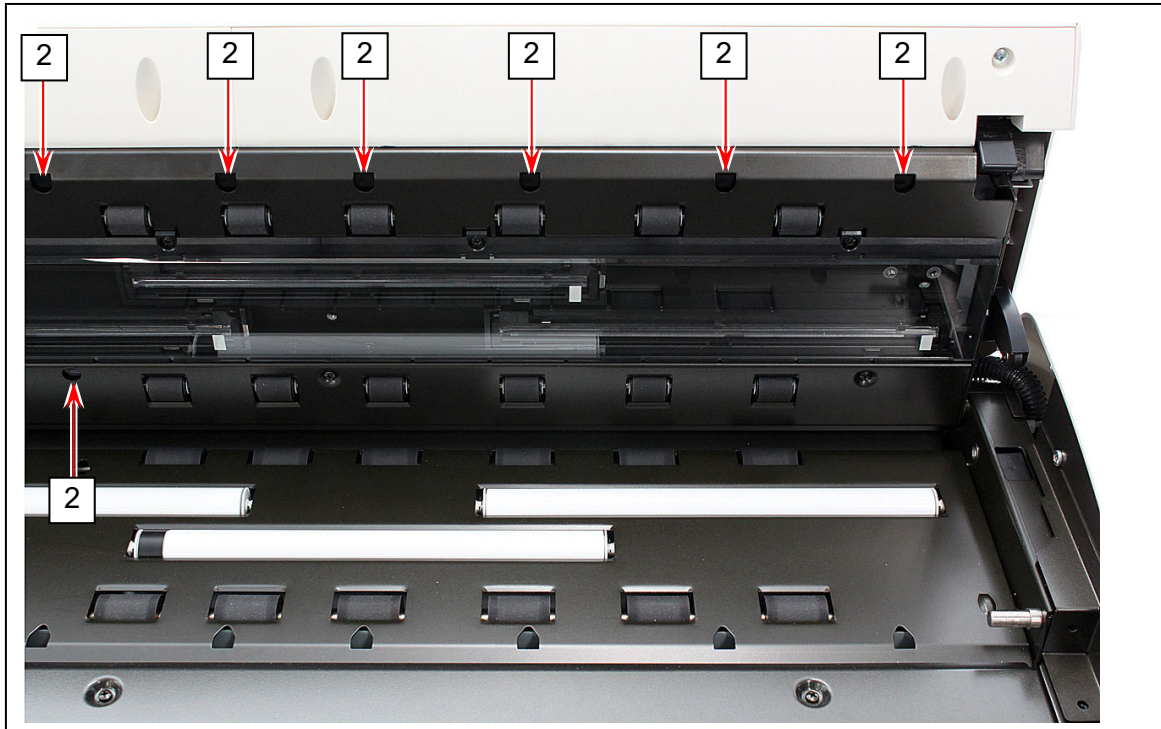

! NOTE

Do not use water, organic solvent, glass cleaner or antistatic spray for cleaning.

4. Gently press Scanner Unit down and firmly close it.



! NOTE

Press down Scanner Unit on both sides to close it.
Do not close it by pressing only one side down.

4.3 Touch Screen

1. Wipe the Touch Screen with a dry cloth.



! NOTE

Do not use water, alcohol, organic solvent, and glass cleaner for the cleaning.

KIP Global Network

America	
America	KIP America, Inc. 39575 W. 13 Mile Road Novi, MI 48377, U.S.A. Phone: +1-248-474-2900 www.kip.com
Canada	KIP Canada, Inc. 2735 Matheson Blvd. East, Suite 4, Mississauga, ON L4W 4M8, Canada Phone: +1-905-206-1177 www.kip.com
Europe	
UK / Europe	KIP Unit 8, Stephenson Close, Drayton Fields, Daventry, Northamptonshire, NN11 8RF, United Kingdom Phone: +44 (0) 1327 304 600 www.kip.com
Asia	
Japan	KIP Corporation 5-1 Yaguchi 1-Chome, Ota-ku, Tokyo 146-0093, Japan Tel: 03-3756-1101 www.kip-net.co.jp
Hong Kong / Macao / Chinese mainland	KIP Hong Kong Ltd. Unit 1508-9, 15/F, Tower A, Regent Centre, 63 Wo Yi Hop Road, Kwai Chung, N.T., Hong Kong Phone: 852 34269168
Chinese mainland	KIP (Beijing) Engineering Copying Equipments Co., Ltd. Room 21505, 12/F, Building 1, Xing Guang Global New Media Center, No.39 Chun He Road, Da Xing District, Beijing, China Phone: 86-10-60298900 www.kipchina.com
Korea	KIP Business Solution Korean Ltd. Room 1802, Halla Sigma Valley Bldg. 345-90, Gasan-dong, Geumcheon-gu, Seoul, 08588, Korea Phone: 82-2-785-8838 www.kipkr.com
South Eastern Asia	KIP Asia Co., Ltd. 200 Soi Baromratchachonnee 2 Bangbamru Bangkok, Thailand 10700, Thailand Phone: 662-4350022-6, 662-8818984-8 www.kip-asia.com
Taiwan	KIP Taiwan 108, Nan-Mei St., Kuei-Shan Taoyuan Phone: 886-3-321-0689 www.kiptaiwan.com

WIDE FORMAT COLOR PRINTER / MFP
KIP 700 Series (KIP 730/740)
Hardware Operation Guide

Ver. A.0 (Issued on May 22, 2023)

Published by Katsuragawa Electric Co., Ltd.
21-1 Shimomaruko 4-Chome,
Ota-ku, Tokyo 146-8585, Japan

Please note that some articles, illustrations and photographs might be partially different from the actual machine because of the modification of machine and so on.

© 2023 Katsuragawa Electric Co., Ltd.

No part of this publication may be copied, reproduced or distributed in any form without express written permission from Katsuragawa Electric Co., Ltd.
